



永州职业技术学院
YONGZHOU VOCATIONAL TECHNICAL COLLEGE

学生专业技能考核题库

（商务英语专业）

永州职业技术学院
2024年7月

目 录

一、专业基本技能模块	2
1. 试题编号：1-1-1 国际商务信息检索与商务文书翻译	2
2. 试题编号：1-1-2 国际商务信息检索与商务文书翻译	6
3. 试题编号：1-1-3 国际商务信息检索与商务文书翻译	11
4. 试题编号：1-1-4 国际商务信息检索与商务文书翻译	16
5. 试题编号：1-1-5 国际商务信息检索与商务文书翻译	21
6. 试题编号：1-1-6 国际商务信息检索与商务文书翻译	26
7. 试题编号：1-1-7 国际商务信息检索与商务文书翻译	31
8. 试题编号：1-1-8 国际商务信息检索与商务文书翻译	35
9. 试题编号：1-1-9 国际商务信息检索与商务文书翻译	40
10. 试题编号：1-1-10 国际商务信息检索与商务文书翻译	44
11. 试题编号：1-1-11 国际商务信息检索与商务文书翻译	49
12. 试题编号：1-1-12 国际商务信息检索与商务文书翻译	55
13. 试题编号：1-1-13 国际商务信息检索与商务文书翻译	60
14. 试题编号：1-1-14 国际商务信息检索与商务文书翻译	65
15. 试题编号：1-1-15 国际商务信息检索与商务文书翻译	69
16. 试题编号：1-1-16 国际商务信息检索与商务文书翻译	74
17. 试题编号：1-1-17 国际商务信息检索与商务文书翻译	79
18. 试题编号：1-1-18 国际商务信息检索与商务文书翻译	84
19. 试题编号：1-1-19 国际商务信息检索与商务文书翻译	89
20. 试题编号：1-1-20 国际商务信息检索与商务文书翻译	94
二、岗位核心技能模块项目一 —— 外贸业务磋商	99
1. 试题编号：2-1-1 外贸业务磋商——建立贸易关系	99
2. 试题编号：2-1-2 外贸业务磋商——付款方式谈判	103
3. 试题编号：2-1-3 外贸业务磋商——价格谈判	107
4. 试题编号：2-1-4 外贸业务磋商技能——投诉与索赔谈判	112
5. 试题编号：2-1-5 外贸业务磋商——包装与运输方式谈判	116

6. 试题编号：2-1-6 外贸业务磋商——付款方式谈判	120
7. 试题编号：2-1-7 外贸业务磋商——投诉与索赔谈判	125
8. 试题编号：2-1-8 外贸业务磋商——建立贸易关系	129
9. 试题编号：2-1-9 外贸业务磋商——价格谈判	134
10. 试题编号：2-1-10 外贸业务磋商——包装与运输方式谈判	139
11. 试题编号：2-1-11 外贸业务磋商——保险条款谈判	144
12. 试题编号：2-1-12 外贸业务磋商——价格谈判	149
13. 试题编号：2-1-13 外贸业务磋商——投诉与索赔谈判	153
14. 试题编号：2-1-14 外贸业务磋商——建立贸易关系	158
15. 试题编号：2-1-15 外贸业务磋商——价格谈判	163
16. 试题编号：2-1-16 外贸业务磋商——包装与运输方式谈判	167
17. 试题编号：2-1-17 外贸业务磋商——保险条款谈判	172
18. 试题编号：2-1-18 外贸业务磋商——建立贸易关系	176
19. 试题编号：2-1-19 外贸业务磋商——投诉与索赔谈判	180
20. 试题编号：2-1-20 外贸业务磋商——价格谈判	185
三、岗位核心技能模块项目二 —— 外贸单证缮制	189
1. 试题编号：2-2-1 信用证审核、单证缮制	189
2. 试题编号：2-2-2 信用证审核、单证缮制	201
3. 试题编号：2-2-3 信用证审核、单证缮制	213
4. 试题编号：2-2-4 信用证审核、单证缮制	224
5. 试题编号：2-2-5 信用证审核、单证缮制	236
6. 试题编号：2-2-6 信用证审核、单证缮制	248
7. 试题编号：2-2-7 合同审核、单证缮制	260
8. 试题编号：2-2-8 合同审核、单证缮制	272
9. 试题编号：2-2-9 合同审核、单证缮制	284
10. 试题编号：2-2-10 合同审核、单证缮制	296
11. 试题编号：2-2-11 合同审核、单证缮制	309
12. 试题编号：2-2-12 合同审核、单证缮制	321
13. 试题编号：2-2-13 信用证审核、单证缮制	334

14. 试题编号：2-2-14	信用证审核、单证缮制	347
15. 试题编号：2-2-15	信用证审核、单证缮制	359
16. 试题编号：2-2-16	信用证审核、单证缮制	372
17. 试题编号：2-2-17	合同审核、单证缮制	385
18. 试题编号：2-2-18	合同审核、单证缮制	397
19. 试题编号：2-2-19	合同审核、单证缮制	409
20. 试题编号：2-2-20	合同审核、单证缮制	421
四、跨岗位综合技能模块		433
1. 试题编号：3-1-1	跨境电商平台综合应用能力	433
2. 试题编号：3-1-2	跨境电商平台综合应用能力	438
3. 试题编号：3-1-3	跨境电商平台综合应用能力	444
4. 试题编号：3-1-4	跨境电商平台综合应用能力	451
5. 试题编号：3-1-5	跨境电商平台综合应用能力	456
6. 试题编号：3-1-6	跨境电商平台综合应用能力	462
7. 试题编号：3-1-7	跨境电商平台综合应用能力	468
8. 试题编号：3-1-8	跨境电商平台综合应用能力	475
9. 试题编号：4-1-9	跨境电商平台综合应用能力	482
10. 试题编号：3-1-10	跨境电商平台综合应用能力	488
11. 试题编号：3-1-11	跨境电商平台综合应用能力	495
12. 试题编号：3-1-12	跨境电商平台综合应用能力	501
13. 试题编号：3-1-13	跨境电商平台综合应用能力	508
14. 试题编号：3-1-14	跨境电商平台综合应用能力	515
15. 试题编号：3-1-15	跨境电商平台综合应用能力	521
16. 试题编号：3-1-16	跨境电商平台综合应用能力	527
17. 试题编号：3-1-17	跨境电商平台综合应用能力	534
18. 试题编号：3-1-18	跨境电商平台综合应用能力	541
19. 试题编号：3-1-19	跨境电商平台综合应用能力	547
20. 试题编号：3-1-20	跨境电商平台综合应用能力	554

永州职业技术学院商务英语专业学生专业技能考核题库

根据永州职业技术学院商务英语专业人才培养方案、学生专业技能考核标准、湖南省教育厅对标准题库设计的原则要求来制定题库。

本题库以对接外贸服务职业岗位工作内容和“1+X”实用英语交际职业技能等级证书培训内容,设置专业基本技能、岗位核心技能、跨岗位综合技能等三个模块四个项目。题库共计80道试题,其中高难度试题16道,占比20%,不低于20%的标准;中等难度试题44道,占比55%;低难度试题20道,占比25%,不超过30%的标准。更新题目数量为22道试题,更新率为27.5%。试题分值设置科学,分值比例分配合理。各项目试题考核时长设置合理,其中专业基本技能模块考核时长为60分钟,岗位核心技能模块考核时长为90分钟,跨岗位综合技能模块考核时长为30分钟,所有项目考核时长均在1-3小时之内。

一、专业基本技能模块

1. 试题编号：1-1-1 国际商务信息检索与商务文书翻译

(1) 任务描述

任务 1：国际商务信息检索(40 分)

内容：关键词检索

要求：阅读并理解所给信息；检索并筛选有效信息；补充完善信息要点。

Section I 国际商务信息检索(40 分)

Directions: Read the following brief introduction to ALDI Group from the official website of the company.

A Brief Introduction to ALDI Group

ALDI Einkauf GmbH & Co. OHG, doing business as ALDI, short for “*Albrecht Discount*”, is a discount supermarket chain based in Germany. The chain is made up of two separate groups, *ALDI Nord* (North — operating as ALDI MARKT), headquartered in Essen, and *ALDI Süd* (South — operating as ALDI Süd), headquartered in Mülheim an der Ruhr, which operate independently from each other within specific market boundaries. The individual groups were originally owned and managed by brothers Karl Albrecht and Theo Albrecht; Karl is Germany’s richest man. Theo was Germany's second richest man until his death in July 2010. ALDI’s German operations currently consist of ALDI Nord’s 35 individual regional companies with about 2,500 stores in western, northern, and eastern Germany, and ALDI Süd’s 31 regional companies with 1,600 stores in western and southern Germany. The ALDI group operates about 8,133 individual stores worldwide. Internationally, ALDI Nord operates in Denmark, France, the Benelux countries, the Iberian peninsula and Poland, while ALDI Süd operates in countries including the Ireland, the United Kingdom, Hungary, Greece, Switzerland, Austria, Slovenia (operating as Hofer in Austria and Slovenia) and Australia. In the United States, ALDI is the parent company of the Trader Joe’s niche food stores, while ALDI Süd operates the main ALDI stores in the country.

History

The earliest roots of the company trace back to 1913, when the mother of Karl Albrecht and Theo Albrecht opened a small store in a suburb of Essen. In 1946, the brothers took over their mother's business and soon opened another retail outlet nearby. By 1950, the Albrecht brothers owned 13 stores in the Ruhr Valley. The brothers' idea, which was new at the time, was to subtract the legal maximum rebate of 3% before sale. The market leaders at the time, which often were co-operatives, required their customers to collect rebate stamps, and to send them at regular intervals to claim their money back. The Albrecht brothers also rigorously removed merchandise that did not sell from their shelves, and cut costs by not advertising, not selling fresh produce, and keeping the size of their retail outlets as small as possible.

When the two brothers split the company in 1960 over a dispute whether they should sell cigarettes at the till or not, they owned 300 shops with a cash flow of DM 90 million per year. In 1962, they introduced the ALDI brand name. Both groups financially and legally separated since 1966, though they describe their relationship as a "friendly relation"; they will also occasionally appear as if they were a single enterprise, for example with certain house brands, or when negotiating with contractor companies. ALDI Group expanded internationally in the 1970s and 1980s, experiencing a rapid expansion in the number of outlets after German reunification and the fall of the Iron Curtain. The brothers retired as CEOs in 1993 and gave most of their wealth to foundations.

Business Practice

ALDI Group specializes in staple items such as food, beverages, toilet paper and other inexpensive household items. Many of its products are own-brand labeled, with the number of outside brands being very limited, usually no more than two different brands for one kind of product, although often only one. This increases the numbers of sales for each article and also allows ALDI Group stores to be smaller than supermarkets which cover the same range of products but with more diversity. This practice also allowed ALDI Group to avoid the use of price tags, even before the introduction of bar code scanners.

However, some brand-name products are carried in certain markets, for example, HARIBO sweets in Germany, Marmite and Branston Pickle in the UK or Vegemite and Milo in Australia. In the US, major brand-name products such as Oscar Mayer Bacon, are occasionally offered as "special buy". The "special buy" programs are name-brand items that ALDI has received at a special price from the vendor and can

offer for a reduced price. Unlike most other stores, ALDI Group does not accept manufacturers' coupons. Some stores in the US did experiment with a store coupon (\$10 off a \$25 purchase) with much success.

In addition to its standard assortment, ALDI Group also has weekly special offers, some of them on more expensive products such as electronics, appliances or computers, usually from Medion. Although not always available, regularly put up for sale are clothing, toys, flowers, gifts.

Company Philosophy

ALDI was founded on the belief that people, wherever they live, should have the opportunity to buy everyday groceries of the highest quality at the lowest possible prices. The company's business model was based on simplicity and efficiency. "Top quality at incredibly low prices- guaranteed", "smarter shopping" and "Spend a little, live a lot" are ALDI's marketing slogans. What began as a simple model for a discount grocery store is now embraced by millions of smart shoppers around the world.

Today, ALDI Group is a leader in the international grocery retailing industry. Streamlined processes, a select brand strategy, a limited and reliable product assortment and double-guarantee philosophy have made it virtually impossible for competitors to match the widespread appeal of ALDI Group.

Task: Search for useful information in the passage and complete the summary below. Fill in each blank with NO MORE THAN THREE WORDS.

ALDI Group Profile

Based in 1. _____, ALDI Group is a chain of 2. _____ and one of the world's largest privately owned companies with about 3. _____ stores worldwide. The group was founded by brothers 4. _____ and Theo Albrecht. They named their company 5. _____ or ALDI for short. In 6. _____ the two brothers split the company into 7. _____ and ALDI Süd. ALDI Group expanded 8. _____ in the 1970s and 1980s, experiencing a rapid expansion in the number of outlets. ALDI Group specializes in 9. _____ such as food, beverages, toilet paper and other inexpensive household items. Its business model was based on 10. _____.

任务 2: 商务文书翻译(50 分)

内容: 商务文书翻译

要求: 阅读并理解所给商务文书; 译文表达专业、术语准确, 符

合商务文体特征；内容完整，逻辑严谨，衔接流畅。

Section II 商务文书翻译(50 分)

Directions: Translate the following advertisement into Chinese.

Lotus (莲花) Slippers (拖鞋) , Buy One and Get One for Free!

The Lotus slippers made by our company are reasonable in price and excellent in quality, which are extremely suitable for all ages. Our products have various colors as well as abundant types with different styles. The slippers are made of environmental protection materials which have neither pollution nor special smelling with exquisite(精致的) workmanship(做工). In order to show our appreciation for the new and old customers, we'll hold promotion activities in October, during which you can buy one and get one for free. Welcome to select and purchase our products!

(2) 实施条件

项目	基本实施条件	备注
场地	每个商务英语实训室配置 40 个操作台面和座位,每个实训室照明通风良好。	必备
设备	每个商务英语实训室配有 1 台服务器、40—50 台计算机,并安装 Office 办公软件,配置局域网。	必备
测评专家	每 40 名考生配备 1 名考评员。考评员要求具备至少二年以上从事国际贸易工作经验或三年以上商务英语实践教学指导经历。	必备

(3) 考核时量

考试时间：60 分钟

(4) 评分标准

模块总分	评价内容	配分	考核点	备注
专业	职业素养与操 (6	2 分	(1) 具备外贸从业人员基本素质,认真严谨、耐心细致、恪守信誉、实事求是、服从安排,听从指挥、举止文明,记 2 分。	在考试过程中不服从安排、举止不得当者,记 0

基本技能模块一：英语语言应用（总分100分，占总评分的30%）	作规范（10分）	分）			分。
		2分	(2)具备外贸从业人员良好的翻译素养，认真严谨，耐心细致，记2分。	考试过程中出现与所述能力及素养不符，扣1-2分。	
		2分	(3)具备外贸从业人员良好的沟通能力、表达能力和合作意识，待人真诚礼貌，记2分。	考试过程中出现与所述能力及素养不符，扣1-2分。	
	操作规范（4分）	2分	(1)具备使用办公设备和 Office 办公软件的能力，在考核过程中以及考核结束后，不私自更换电脑、不随意关闭或重启电脑，没征求监考老师同意不随意提前或推迟交卷，记2分。	若私自更换电脑、随意关闭或重启电脑，记0分。	
		2分	(2)能严格遵守企业 6S 管理要求（整理、整顿、清扫、清洁、素养、安全），记2分。	若未遵守企业 6S 管理要求，记0分。	
	作品（90分）	国际商务信息检索（40分）	10分	(1)阅读并理解所给外贸公司介绍资料，检索、筛选有效信息，记10分。	
			30分	(2)补充完善信息要点，每空不超过3个单词，每空3分，共10空，记30分。	大小写错误每处扣0.5分；答案不完整每处扣1分；拼写错误每处计0分
		商务文书翻译（50分）	15分	(1)能准确理解所给商务文书，语义信息理解正确，内容完整，记15分。	主要内容每缺失1处，扣2分
			15分	(2)能熟练运用商务翻译技巧、国际贸易和英语语言综合知识，语言表达通顺，符合商务文体特征，记15分。	专业术语、贸易惯例、法规、条款等翻译错误，每2处错误扣1分。
			10分	(3)语言表达通顺，语法、句型使用正确，记10分。	单词、语法每错3处扣1分。
10分	(4)译文表达准确，双语转换顺畅，体裁运用恰当，标点运用正确，记10分。	错别字、标点、句型表达，每2处错误扣1分。			

2. 试题编号：1-1-2 国际商务信息检索与商务文书翻译

(1) 任务描述

任务 1：国际商务信息检索(40分)

内容：关键词检索

要求：阅读并理解所给信息；检索并筛选有效信息；补充完善信息要点。

Section I 国际商务信息检索(40 分)

Directions: Read the following brief introduction to TJ Morris Ltd. from the official website of the company.

A Brief Introduction to TJ Morris Ltd.

TJ Morris Ltd. was established over 30 years ago by Tom Morris. Tom comes from a retailing family that has run shops for three generations. Following the family tradition, TJ Morris Ltd. remains a family-run and family-owned business. The business operates on one key principle: to sell branded goods at the lowest prices possible. The company now boasts over 250 stores and employs more than 7,000 staff. Its primary business is in its UK based Home Bargains stores, formally known as Home & Bargains. Home Bargains stores have red and sky blue branding. They can usually be found in major shopping streets as well as in shopping centers and arcades. They are well known for being bright, attractive and welcoming and our friendly staffs are always on hand to serve your needs.

Since opening his first store in Liverpool, Tom has grown the business organically to become one of the biggest privately owned companies in the UK. It is widely regarded as one of the largest businesses in Merseyside and is the third largest independent grocer in the country according to The Grocer Magazine. It is the most profitable of any of the listed grocers by an impressive margin. The retailer actually holds one third of the entire profit of the sum of the companies on the list. It carries a wide range of top quality brands — from health and beauty products to household goods, food, toys and so much more — all at prices that other retailers struggle to match.

Over the next six months, the company is investing £15 million in opening 30 new stores across the country, creating 1,200 new jobs for the U.K. It intends to double its business in the next three to four years. By 2015, it expects to hit its billion pound turnover target, grow the number of stores nationwide to 350 stores — with the potential for 600 across the UK; and employ more than 10,000 staff. Work is almost completed on the company's £35 million distribution centre at the Axis Business Park

in Liverpool—which will enable it to grow its 170-strong store network and further increase its turnover and create 800 new jobs for Merseyside. The company’s ongoing success comes as a number of major high street retailers announce slumps in sales, shock profit warnings, and sliding share prices.

The company has launched a new corporate website along with the e-commerce site. It has reinforced its ambitious growth plans with the launch of a new e-commerce website, www.homebargains.co.uk. In addition, The company—which recently joined The Sunday Times Top Track 100—will use its £35m distribution centre in Gillmoss to supply online customers, as well as its 250 stores across the U.K.

The website sells many of the same products that are available in Home Bargains stores, including toys and games, homeware, furniture and entertainment. However, shoppers can not yet buy food and drink via the site.

“We are focusing on adding larger high-value products first,” a spokeswoman said. “As the website develops, the range will be expanded to include more items. Smaller items like food and drinks, plus toiletries like mouthwash and shower gel, are all in the pipeline.”

The website also offers “Group Buys”, one-off special deals where there is a limited amount of stock available. Current deals include a Peppa Pig bed for £9.99 offering a saving of £40. The site also advertises the retailer’s “Star Buys” special offers and deals of the week.

The move is TJ Morris’ second attempt at online retail. It launched www.halfpriceorless.com in 2000, and it proved very successful, being voted by customers as runner-up to Easy Jet in the Visa E-tail awards – Best Value Website category. The site ran for just under three years before it was closed, as the company concentrated on further store openings.

Joe Morris, operations director of TJ Morris, comments: “We learned a lot through our initial e-commerce venture 10 years ago. E-commerce is now an indispensable part of the retail landscape and we need to offer our customers this service. Every week we receive customer enquiries asking us when they’ll be able to shop online – now they can.”

Task : Search for useful information in the passage and complete the summary below. Fill in each blank with NO MORE THAN THREE WORDS.

<p>TJ Morris Ltd. Profile</p> <p>Established over 30 years ago by 1. _____, TJ Morris Ltd. operates his</p>
--

business on one core principle: to sell branded goods at 2. _____ possible. With more than 3. _____ stores and over 7,000 staff, its main business is in its 4. _____ Home Bargains stores, which have red and sky blue branding. It is the third largest independent grocer in the country according to The Grocer Magazine. It is the most profitable of any of the the listed grocers by 5. _____, holding 6. _____ of the entire profit of the sum of all listed companies. It provides a wide range of top quality brands, from health and 7. _____ to household goods, food, toys and 8. _____. By 2015, it expects to reach its billion pound target. Recently, it has launched a new e-commerce website to sell many of the same products that are available in 9. _____ except for 10. _____.

任务 2: 商务文书翻译(50 分)

内容: 商务文书翻译

要求: 阅读并理解所给商务文书; 译文表达专业、术语准确, 符合商务文体特征; 内容完整, 逻辑严谨, 衔接流畅。

Section II 商务文书翻译(50 分)

Directions: Translate the following product description into Chinese.

1.Product: Seagull(海鸥) brand energy-saving battery
2.Model: DMC
3.Specification: 72V/200 Ah
4.Height: 47.5mm
5.Width: 115.5mm
6.Length: 215.5mm
7.Features of the products: Safe, environmental protection and easy to carry with
8.Using Instruction: Please charge no more than 6 hours each time and no less than 12 hours for the first charging.
9.Warning: Please don't put the battery into the fire nor store it in the high temperature environment.

(2) 实施条件

项目	基本实施条件	备注
场地	每个商务英语实训室配置 40 个操作台面和座位,每个实训室照明通风良好。	必备
设备	每个商务英语实训室配有 1 台服务器、40—50 台计算机,并安装 Office 办公软件,配置局域网。	必备
测评专家	每 40 名考生配备 1 名考评员。考评员要求具备至少二年以上从事国际贸易工作经验或三年以上商务英语实践教学指导经历。	必备

(3) 考核时量

考试时间：60 分钟

(4) 评分标准

模块总分		评价内容	配分	考核点	备注
专业基本技能模块一：英语语言应用（总分 100	职业素养与操作规范（10分）	职业素养（6分）	2分	（1）具备外贸从业人员基本素质，认真严谨、耐心细致、恪守信誉、实事求是、服从安排，听从指挥、举止文明，记 2 分。	在考试过程中不服从安排、举止不得当者，记 0 分。
			2分	（2）具备外贸从业人员良好的翻译素养，认真严谨，耐心细致，记 2 分。	考试过程中出现与所述能力及素养不符，扣 1-2 分。
			2分	（3）具备外贸从业人员良好的沟通能力、表达能力和合作意识，待人真诚礼貌，记 2 分。	考试过程中出现与所述能力及素养不符，扣 1-2 分。
		操作规范（4分）	2分	（1）具备使用办公设备和 Office 办公软件的能力，在考核过程中以及考核结束后，不私自更换电脑、不随意关闭或重启电脑，没征求监考老师同意不随意提前或推迟交卷，记 2 分。	若私自更换电脑、随意关闭或重启电脑，记 0 分。
	2分		（2）能严格遵守企业 6S 管理要求（整理、整顿、清扫、清洁、素养、安全），记 2 分。	若未遵守企业 6S 管理要求，记 0 分。	
作品	国际	10分	（1）阅读并理解所给外贸公司介绍资料，		

分, 占总评分的 30%)	(90分)	商务信息检索 (40分)		检索、筛选有效信息, 记 10 分。	
			30 分	(2) 补充完善信息要点, 每空不超过 3 个单词, 每空 3 分, 共 10 空, 记 30 分。	大小写错误每处扣 0.5 分; 答案不完整每处扣 1 分; 拼写错误每处计 0 分
	商务文书翻译 (50分)	15 分	(1) 能准确理解所给商务文书, 语义信息理解正确, 内容完整, 记 15 分。	主要内容每缺失 1 处, 扣 2 分	
		15 分	(2) 能熟练运用商务翻译技巧、国际贸易和英语语言综合知识, 语言表达通顺, 符合商务文体特征, 记 15 分。	专业术语、贸易惯例、法规、条款等翻译错误, 每 2 处错误扣 1 分。	
		10 分	(3) 语言表达通顺, 语法、句型使用正确, 记 10 分。	单词、语法每错 3 处扣 1 分。	
10 分	(4) 译文表达准确, 双语转换顺畅, 体裁运用恰当, 标点运用正确, 记 10 分。	错别字、标点、句型表达, 每 2 处错误扣 1 分。			

3. 试题编号: 1-1-3 国际商务信息检索与商务文书翻译

(1) 任务描述

任务 1: 国际商务信息检索(40 分)

内容: 关键词检索

要求: 阅读并理解所给信息; 检索并筛选有效信息; 补充完善信息要点。

Section I 国际商务信息检索(40 分)

Directions: Read the following brief introduction to Foremost International Ltd. from the official website of the company.

A Brief Introduction to Foremost International Ltd.

Foremost International Ltd. is a home furnishings manufacturer that markets and sells its products worldwide. It was formed in 1988 around a simple principle, "To satisfy our customers with stylish, innovative products supported by efficient, friendly service." In the years that followed, the company has held true to its mission, developing four product divisions (Bathroom Furniture, Outdoor Furniture, Indoor

Furniture and Food Service Equipment) producing world-class goods that offer superior design, engineering and value for consumers and industry.

The company produces a range of pieces for every room in the house, including home offices (computer desks, storage units), living rooms (ottomans, entertainment centers), and bathrooms (cabinets, toilets). It also makes patio sets and food service equipment. Its furniture is manufactured under the Foremost, Foremost Casual, Veranda Classics, and Fireworks brands, as well as private-label names for major retailers. From design through fulfillment, the mission is to be recognized by our customers as the leader in home furnishings.

Foremost International Ltd. operations combine the strength of quality, design-driven production and market ingenuity to create a value that is unsurpassed in the markets it serves. Through close collaborations with customers and partners, they have developed innovative products for customers. For years, it has been manufacturing and distributing its products to retail companies and wholesalers around the world. Its production facilities in the United States and overseas use state-of-the-art, precision equipment and employ thousands of workers worldwide, providing opportunity, jobs and a pride that transcends borders and continents.

Its employees are committed to honesty, respect, trust, sharing, hard work and quality in all they do. They begin with classic design elements and combine them with innovative ideas to bring timeless beauty and modern functionality to the products. Because furniture has a wide range of styles, they use a broad selection of premium materials that complement and enhance each design. The skilled technicians combine time honored manufacturing techniques, and the highest quality materials, to hand build each piece of furniture for your home. Their dedication to their craft, combined with our dedication to maintaining the highest product quality standards, corporate efficiencies, and continuous improvement, make Foremost the furniture industry leader in producing quality home furnishings.

Foremost is committed to environmental responsibility. Because responsibility does not stop at national borders, the company is working to protect and sustain global environment. By designing products that meet EPA standards like Water Sense qualifying toilets that provide high efficiency waste removal while using 20% less water with every flush, Foremost is using innovative engineering to make the most of our resources. But that's just a part of what Foremost does to insure sustainability.

The bath vanities and furniture use California Air Resource Board (CARB)

Phase II compliant wood products which limit urea-formaldehyde emissions into the environment. Foremost only uses wood products from managed forest resources to discourage clear-cut logging and the depletion of global rainforests. It encourages customers to order products using material that is Forest Stewardship Council (FSC) certified, insuring the responsible use of forest resources and equitable treatment of indigenous people of producing regions.

Foremost has also earned the Kitchen Cabinet Manufacturers Association's (KCMA) Environmental Stewardship Program (ESP) certification for meeting requirements in the areas of air quality, product and process resource management, environmental stewardship, and community relations.

Even our packaging and our marketing materials are eco-friendly. We are in constant pursuit of new innovative manufacturing technologies, materials and packaging that will reduce our waste and limit the use of virgin materials even more. Our catalog is printed on Forest Stewardship Council (FSC) certified paper (FCS SGS Ref No.:11562561-4), and this binder itself is one of the most environmentally friendly on the market called "The Earth Binder". Its front and back covers are made from 100% recycled residential mixed paper. Its spine is made from material that is FSC certified. It uses 20% recycled content in the steel rings and is printed using biodegradable inks.

Task : Search for useful information in the passage and complete the summary below. Fill in each blank with NO MORE THAN THREE WORDS.

Foremost International Ltd. Profile

Foremost International Ltd. is a 1. _____ that operates around a simple principle, "To satisfy our customers with 2. _____, innovative products supported by efficient, friendly service." Since its initial start in 3. _____, the company has developed four product divisions, namely, Bathroom Furniture, Outdoor Furniture, Indoor Furniture and 4. _____. The furniture is manufactured under the Foremost, Foremost Casual, 5. _____, and Fireworks brands, as well as private-label names for major retailers. The company is committed to environmental responsibility. Its Water Sense qualifying toilets provide high efficiency waste removal while using 6. _____ less water with every flush. The bath vanities and 7. _____ use CARB Phase II compliant wood. It has also won KCMA's ESP certification for meeting requirements in the areas of 8. _____, product and process resource management, 9. _____, and community relations.

Moreover, the packaging and marketing materials are also 10._____.

任务 2: 商务文书翻译(50 分)

内容: 商务文书翻译

要求: 阅读并理解所给商务文书; 译文表达专业、术语准确, 符合商务文体特征; 内容完整, 逻辑严谨, 衔接流畅。

Section II 商务文书翻译(50 分)

Directions: Translate the following product description into Chinese.

Beauty Brand Furniture Specification

Brand: Beauty

Manufacturer: Hunan Provincial Light Industrial Products Corporation Ltd.

Model: DMZ

Height: 2m

Length: 2.5m

Width: 3m

Color: Gray

Usage: Office

Material: Environmental protection woods with water proof function

Installation (安装): Please operate according to the specification strictly; All the spare parts are contained in the sealed carton.

Quality assurance (质保): One-month free of change, three-month free of maintenance

Caution: Avoid long time sunlight

If you have any problem, please do not hesitate to call us at 400-123-455.

(2) 实施条件

项目	基本实施条件	备注
场地	每个商务英语实训室配置 40 个操作台面和座位, 每个实训室照明通风良好。	必备
设备	每个商务英语实训室配有 1 台服务器、40—50 台计算机, 并安装 Office 办公软件, 配置局域网。	必备

测评专家	每 40 名考生配备 1 名考评员。考评员要求具备至少二年以上从事国际贸易工作经验或三年以上商务英语实践教学指导经历。	必备
------	---	----

(3) 考核时量

考试时间：60 分钟

(4) 评分标准

模块总分	评价内容	配分	考核点	备注	
专业基本技能模块一：英语语言应用（总分 100 分，占总评分的 30%）	职业素养与操作规范（10 分）	2 分	(1) 具备外贸从业人员基本素质，认真严谨、耐心细致、恪守信誉、实事求是、服从安排，听从指挥、举止文明，记 2 分。	在考试过程中不服从安排、举止不得当者，记 0 分。	
		2 分	(2) 具备外贸从业人员良好的翻译素养，认真严谨，耐心细致，记 2 分。	考试过程中出现与所述能力及素养不符，扣 1-2 分。	
		2 分	(3) 具备外贸从业人员良好的沟通能力、表达能力和合作意识，待人真诚礼貌，记 2 分。	考试过程中出现与所述能力及素养不符，扣 1-2 分。	
	操作规范（4 分）	2 分	(1) 具备使用办公设备和 Office 办公软件的能力，在考核过程中以及考核结束后，不私自更换电脑、不随意关闭或重启电脑，没征求监考老师同意不随意提前或推迟交卷，记 2 分。	若私自更换电脑、随意关闭或重启电脑，记 0 分。	
		2 分	(2) 能严格遵守企业 6S 管理要求（整理、整顿、清扫、清洁、素养、安全），记 2 分。	若未遵守企业 6S 管理要求，记 0 分。	
	作品（90 分）	国际商务信息检索（40 分）	10 分	(1) 阅读并理解所给外贸公司介绍资料，检索、筛选有效信息，记 10 分。	
			30 分	(2) 补充完善信息要点，每空不超过 3 个单词，每空 3 分，共 10 空，记 30 分。	大小写错误每处扣 0.5 分；答案不完整每处扣 1 分；拼写错误每处计 0 分
	商务	15 分	(1) 能准确理解所给商务文书，语义信	主要内容每缺	

	文书 翻译 (50 分)		息理解正确，内容完整，记 15 分。	失 1 处，扣 2 分
		15 分	(2) 能熟练运用商务翻译技巧、国际贸易和英语语言综合知识，语言表达通顺，符合商务文体特征，记 15 分。	专业术语、贸易惯例、法规、条款等翻译错误，每 2 处错误扣 1 分。
		10 分	(3) 语言表达通顺，语法、句型使用正确，记 10 分。	单词、语法每错 3 处扣 1 分。
		10 分	(4) 译文表达准确，双语转换顺畅，体裁运用恰当，标点运用正确，记 10 分。	错别字、标点、句型表达，每 2 处错误扣 1 分。

4. 试题编号：1-1-4 国际商务信息检索与商务文书翻译

(1) 任务描述

任务 1：国际商务信息检索(40 分)

内容：关键词检索

要求：阅读并理解所给信息；检索并筛选有效信息；补充完善信息要点。

Section I 国际商务信息检索(40 分)

Directions: Read the following brief introduction to SKP from the official website of the company.

A Brief Introduction to SKP

Seow Khim Polythelene Co Pte Ltd. (SKP) was founded in 1979 and incorporated in 1994. It has revolutionized the plastics disposable packaging industry, and indirectly, the entire food and beverage industry in Singapore and world. Now it has 46 retail branches island wide and occupies 240,000 sqf of facilities.

SKP's products are consumed locally and overseas. It is the largest supplier of disposable plastic packaging in the local market, commanding 70% of the market share. SKP possesses a well established and wide business network overseas that spread across 4 continents. The markets include U.S.A., United Kingdom, Australia, Japan, Europe, Middle East and Korea, etc. The goods are sold to popular restaurants, fast food chains, coffee shops, supermarkets, coffee-clubs, and food courts around the

island. They can supply take-away meals to their consumers using SKP's disposable packaging; thus increasing their business and bringing added convenience to today's busy working class. These containers are micro-wave safe, thereby making a significant impact on modern lifestyle, as food can be stored, heated and eaten off the same container .

The Management, led by Chairman, Mr. Lim Seow Khim and his 4 dynamic brothers, are keen observers of market trends. Every member of the senior management takes a personal interest in quality control and product development. They are able to spot opportunities for growth long before others consider it feasible.

These are some of the "first" they have scored:

The introduction of thin walled plastic disposable containers;

Investment in multi-million dollar technology, including the most advanced double-sided moulds, the best machines and the engagement of skilled technicians; Introduction of full color print on plastic cups, it remains the only company with this capability;

Introduction of thermoforming production which manufactures plastic containers that are flexible and durable, thus defeating the shortcomings of rigidity and brittleness of moulded containers.

Now SKP is fully computerized in all its administrative and inventory control functions. The company has spent more than \$500,000 on its computer system. The customized networks system is linked to all departments for better integration and command and control. This investment has resulted in greater efficiency workforce. The huge investments in technology were made with the consumers' needs foremost in mind. While SKP made its conquests in speed and quantity, it also meticulously paid attention to detail. As a result, our company has established a strong reputation for quality, and many customers insist on our products exclusively. SKP intends to be the low-cost global leader in providing customer-preferred packaging solutions to selected value-added segments. Its dedicated team of packaging design engineers and materials experts collaborates with customers to help them differentiate their products with more convenient and functional packaging in a wide variety of markets. They focus on four areas to deliver customer's need:

Speed to market – Our success at simplifying the supply chain helps us significantly reduce lead time to get your product to market quickly.

Flexibility – Our efforts are focused on you. We constantly listen to our

customers and adapt to meet your needs.

Design and development – We give you tangible and visual feedback throughout the development stage by using our sophisticated software and technologies:

Sophisticated 3-D modeling software

Finite Element Analysis (FEA) – Optimizes design and weight

Structural analysis

Mold-fill analysis

Mold-flow simulation

Continuous improvement – More than 100 years of corporate commitment go into our focus on quality improvement, cost-to-produce improvements, and customer satisfaction.

Above all, SKP has a strong record in the area of corporate sustainability, reflecting the company's recognition that sustainability is an important issue to our customers, shareholders, employees and other key stakeholders. In 2005, SKP identified the need for a more comprehensive approach for the future and formed a corporate sustainability committee with the overarching goal of ensuring SKP's leadership position in sustainability by continuing to integrate the concept into the company's business strategy and culture. The SKP corporate sustainability committee provides oversight, guidance and direction on social, community and environmental issues that have potential impact on the reputation and long-term economic viability of the company and our stakeholders.

Task: Search for useful information in the passage and complete the summary below. Fill in each blank with NO MORE THAN THREE WORDS.

SKP Profile

Founded in 1. _____, Seow Khim Polythelene Co Pte Ltd. (SKP) has revolutionized the 2. _____ industry, and become the 3. _____ supplier in Singapore. With 4. _____ of the market share in the local market, it also possesses a wide range of oversea markets including U.S.A., United Kingdom, Australia, Japan, 5. _____, Middle East and Korea, etc. The products are sold to popular restaurants, 6. _____, coffee shops, supermarkets, coffee-clubs, food courts around the island. The Management, Mr. Lim Seow Khim and his 7. _____ dynamic brothers, is paying close attention to market trends. They have spent over 8. _____ in the computer system. They focus on four areas to deliver customer's need: speed to market, flexibility, 9. _____, and

continuous improvement. SKP has a strong record in the area of 10._____, which is an important issue to customers, shareholders, employees and other key stakeholders.

任务 2: 商务文书翻译(50 分)

内容: 商务文书翻译

要求: 阅读并理解所给商务文书; 译文表达专业、术语准确, 符合商务文体特征; 内容完整, 逻辑严谨, 衔接流畅。

Section II 商务文书翻译(50 分)

Directions: Translate the following product description into Chinese.

Plastic Food Container

Brand: Rubbermaid(乐柏美)

Manufacturer: SKP

Product Dimensions: 8×16×10 inches

Weight: 1 pound

Product Description: Square in shape and allow for easy of stacking(叠放); BPA free(不含双酚 A); safe to use in refrigerator, freezer, microwave, and dishwasher; ideal to store cookies, cupcakes and other baked goods. Perfect food storage choice for family outing and picnic party.

With Rubbermaid's plastic food container, you'll find storage and organization a breeze!

(2) 实施条件

项目	基本实施条件	备注
场地	每个商务英语实训室配置 40 个操作台面和座位, 每个实训室照明通风良好。	必备
设备	每个商务英语实训室配有 1 台服务器、40—50 台计算机, 并安装 Office 办公软件, 配置局域网。	必备
测评专家	每 40 名考生配备 1 名考评员。考评员要求具备至少二年以上从事国际贸易工作经验或三年以上商务英语实践教学指导经历。	必备

(3) 考核时量

考试时间：60 分钟

(4) 评分标准

模块总分	评价内容	配分	考核点	备注	
专业基本技能模块一：英语语言应用（总分100分，占总评分的30%）	职业素养与操作规范（10分）	2分	（1）具备外贸从业人员基本素质，认真严谨、耐心细致、恪守信誉、实事求是、服从安排，听从指挥、举止文明，记2分。	在考试过程中不服从安排、举止不得当者，记0分。	
		2分	（2）具备外贸从业人员良好的翻译素养，认真严谨，耐心细致，记2分。	考试过程中出现与所述能力及素养不符，扣1-2分。	
		2分	（3）具备外贸从业人员良好的沟通能力、表达能力和合作意识，待人真诚礼貌，记2分。	考试过程中出现与所述能力及素养不符，扣1-2分。	
		2分	（1）具备使用办公设备和 Office 办公软件的能力，在考核过程中以及考核结束后，不私自更换电脑、不随意关闭或重启电脑，没征求监考老师同意不随意提前或推迟交卷，记2分。	若私自更换电脑、随意关闭或重启电脑，记0分。	
		2分	（2）能严格遵守企业 6S 管理要求（整理、整顿、清扫、清洁、素养、安全），记2分。	若未遵守企业 6S 管理要求，记0分。	
		10分	（1）阅读并理解所给外贸公司介绍资料，检索、筛选有效信息，记10分。		
	作品（90分）	30分	（2）补充完善信息要点，每空不超过3个单词，每空3分，共10空，记30分。	大小写错误每处扣0.5分；答案不完整每处扣1分；拼写错误每处计0分	
		商务文书翻译（50分）	15分	（1）能准确理解所给商务文书，语义信息理解正确，内容完整，记15分。	主要内容每缺失1处，扣2分
			15分	（2）能熟练运用商务翻译技巧、国际贸易和英语语言综合知识，语言表达通顺，符合商务文体特征，记15分。	专业术语、贸易惯例、法规、条款等翻译错误，每2处错误扣1

				分。
		10分	(3) 语言表达通顺, 语法、句型使用正确, 记 10 分。	单词、语法每错 3 处扣 1 分。
		10分	(4) 译文表达准确, 双语转换顺畅, 体裁运用恰当, 标点运用正确, 记 10 分。	错别字、标点、句型表达, 每 2 处错误扣 1 分。

5. 试题编号: 1-1-5 国际商务信息检索与商务文书翻译

(1) 任务描述

任务 1: 国际商务信息检索(40 分)

内容: 关键词检索

要求: 阅读并理解所给信息; 检索并筛选有效信息; 补充完善信息要点。

Section I 国际商务信息检索(40 分)

Directions: Read the following brief introduction to Naseeb International Corp. from the official website of the company.

A Brief Introduction to Naseeb International Corp.

Naseeb International Corp. is a major distributor of fast moving consumer goods (FMCG). Established in 1989, Naseeb International Corp. is engaged in the manufacture, import and wholesale of a variety of consumer goods. We offer excellent discounts to the trade and retailers. We carry a vast range of products to choose from, including: Bed & Bath, Giftware, Home Hardware, Kitchenware, Household Items, Cosmetics, Electronics and much more. The quality of our products is backed by our vast experience and skill, which is particularly important since many of our products are made and finished by hand. All goods bought from our wholesale stock can be resold at a profit so that you can compete favorably with high street stores. Purchase from our wholesale and we will help you increase your profit margins.

To match the pace of growth of our international business, we are focusing on improving transaction systems and messaging platforms. We have launched a supplier portal that includes an automated digital document exchange facility that will improve

the efficiency and effectiveness of interaction with suppliers. The supply chain runs through a wide spectrum of functions right from materials planning to procurement to primary distribution. It has played a pivotal role in improving operational efficiencies and creating agile procurement, production and delivery systems. It has also enhanced the flexibility of operations, lowered output time and reduced delivery costs, while improving customer-servicing levels and profitability.

At Naseeb International Corp., Research & Development has played a significant role in the growth of the organization. We invest nearly €1 billion every year in research and development, and have established laboratories around the world where our scientists explore new thinking and techniques, applying their expertise to our products. We have continued to stay in the forefront of technology that fuels business growth. Our technologists not only develop new products and improve upon existing formulations; but also act as a pillar of support to other functions, via

Supports manufacturing in process cycle time reduction & improves productivity by alternate / break through processes;

Provides solutions to environmental issues by minimizing waste at the time of generation and also in recycling;

Aids marketing in providing technical tools to demonstrate and push new products;

Supports materials by providing new raw materials as alternate to current one to give them negotiating power and also alternate vendors for supply chain flexibility.

Customers are the very core of all our business activities. From the beginning, we have fostered a customer-centric approach to business. Consumer research plays a vital role in this process. Our unrivalled global reach allows us to get closer to consumers in local and international markets, ensuring we understand their diverse needs and priorities. The company is manned by a technical and customer service staff that is both knowledgeable and courteous. Each customer service specialist possesses an in-depth knowledge of his/her manufacturers and customers, and works closely with both to provide detailed information concerning order entry, shipments, order tracking, invoicing, returns, pricing discrepancies, special promotions, and all other facets of the order placement and fulfillment procedure. Customer service representatives in our regional offices work closely with sales personnel to provide administrative support, and communicate on a daily basis with our corporate headquarters to ensure accurate and current sales data. We maintain close personal

interaction with each of our customers, providing necessary support in various areas including product mix determination, presentation and point of sale promotion. Simultaneously, the valuable feedback received from our customers facilitates continuous product development, enabling us to offer unique products and designs.

Our market environment is subject to constant change. New sales channels evolve customer needs and new competitors. Change is a constant feature of our day-to-day business life. Thus, we apply the SMART principle to encourage our staff to set ambitious objectives. SMART means:

S – short (expressed concisely),

M – measurable,

A – achievable,

R – realistic,

T – time-bound (with schedules and deadlines).

Clear delegation requires goals to be well formulated. Only when something is clear, can it be successfully put into effect. SMART objectives are the hallmark of the good leadership which we aim to achieve throughout Naseeb International Corp..

Task: Search for useful information in the passage and complete the summary below. Fill in each blank with NO MORE THAN THREE WORDS.

Naseeb International Corp. Profile

Established in 1. _____, Naseeb International Corp. is engaged in the manufacture, import and 2. _____ of a variety of consumer goods, including: Bed & Bath, Giftware, Home Hardware, 3 _____, Household Items, Cosmetics, Electronics and much more. They focus on improving transaction systems and 4. _____ to facilitate our global growth. The supply chain runs through a wide spectrum of functions right from materials planning to 5. _____ to primary distribution. 6. _____ are the very core of all its business activities. Its global consumer research allows us to get closer to consumers in local and international markets, ensuring they understand their diverse needs and 7. _____. The market environment is subject to 8. _____. They apply the 9. _____ principle to encouraging their staff to set ambitious objectives. This principle is the 10. _____ of the good leadership which they aim to achieve throughout Naseeb International Corp..

任务 2: 商务文书翻译(50 分)

内容：商务文书翻译

要求：阅读并理解所给商务文书；译文表达专业、术语准确，符合商务文体特征；内容完整，逻辑严谨，衔接流畅。

Section II 商务文书翻译(50分)

Directions: Translate the following agenda into Chinese.

	Morning	Afternoon
Monday (Dec. 2nd)	9:00-11:00 a.m. Meet with Mr. Liu, manager of Hunan Provincial Light Industrial Products Corporation Ltd.	2:00-4:00 p.m. Visit the plant (工厂)
Tuesday (Dec. 3rd)	9:00-10:00 a.m. Do market research	2:00-4:00 p.m. Attend the annual meeting of import & export department
Wednesday (Dec. 4th)	Draw up the contract	
Thursday (Dec. 5th)	9:00-12:00 a.m. Discuss the details of the contract	2:30-3:00 p.m. Sign the contract with Hunan Provincial Light Industrial Products Corporation Ltd.
Friday (Dec. 6th)	8:00-12:00 a.m. Visit some places of interest	2:00 p.m. Take flight CS2018 to go back to America

(2) 实施条件

项目	基本实施条件	备注
场地	每个商务英语实训室配置 40 个操作台面和座位,每个实训室照明通风良好。	必备

设备	每个商务英语实训室配有 1 台服务器、40—50 台计算机，并安装 Office 办公软件，配置局域网。	必备
测评专家	每 40 名考生配备 1 名考评员。考评员要求具备至少二年以上从事国际贸易工作经验或三年以上商务英语实践教学指导经历。	必备

(3) 考核时量

考试时间：60 分钟

(4) 评分标准

模块总分		评价内容	配分	考核点	备注
专业基本技能模块一：英语语言应用（总分 100 分，占总评分	职业素养与操作规范（10 分）	职业素养（6 分）	2 分	(1) 具备外贸从业人员基本素质，认真严谨、耐心细致、恪守信誉、实事求是、服从安排，听从指挥、举止文明，记 2 分。	在考试过程中不服从安排、举止不得当者，记 0 分。
			2 分	(2) 具备外贸从业人员良好的翻译素养，认真严谨，耐心细致，记 2 分。	考试过程中出现与所述能力及素养不符，扣 1-2 分。
			2 分	(3) 具备外贸从业人员良好的沟通能力、表达能力和合作意识，待人真诚礼貌，记 2 分。	考试过程中出现与所述能力及素养不符，扣 1-2 分。
		操作规范（4 分）	2 分	(1) 具备使用办公设备和 Office 办公软件的能力，在考核过程中以及考核结束后，不私自更换电脑、不随意关闭或重启电脑，没征求监考老师同意不随意提前或推迟交卷，记 2 分。	若私自更换电脑、随意关闭或重启电脑，记 0 分。
	2 分		(2) 能严格遵守企业 6S 管理要求（整理、整顿、清扫、清洁、素养、安全），记 2 分。	若未遵守企业 6S 管理要求，记 0 分。	
	作品（90 分）	国际商务信息检索（40 分）	10 分	(1) 阅读并理解所给外贸公司介绍资料，检索、筛选有效信息，记 10 分。	
		30 分	(2) 补充完善信息要点，每空不超过 3 个单词，每空 3 分，共 10 空，记 30 分。	大小写错误每处扣 0.5 分；答案不完整每处扣 1 分；拼写错误每	

的 30%)	商务 文书 翻译 (50 分)	15分	(1) 能准确理解所给商务文书, 语义信息理解正确, 内容完整, 记 15 分。	处计 0 分 主要内容每缺失 1 处, 扣 2 分
		15分	(2) 能熟练运用商务翻译技巧、国际贸易和英语语言综合知识, 语言表达通顺, 符合商务文体特征, 记 15 分。	专业术语、贸易惯例、法规、条款等翻译错误, 每 2 处错误扣 1 分。
		10分	(3) 语言表达通顺, 语法、句型使用正确, 记 10 分。	单词、语法每错 3 处扣 1 分。
		10分	(4) 译文表达准确, 双语转换顺畅, 体裁运用恰当, 标点运用正确, 记 10 分。	错别字、标点、句型表达, 每 2 处错误扣 1 分。

6. 试题编号: 1-1-6 国际商务信息检索与商务文书翻译

(1) 任务描述

任务 1: 国际商务信息检索(40 分)

内容: 关键词检索

要求: 阅读并理解所给信息; 检索并筛选有效信息; 补充完善信息要点。

Section I 国际商务信息检索(40 分)

Directions: Read the following brief introduction to Novozymes from the official website of the company.

A Brief Introduction to Novozymes

Novozymes is the world leader in bioinnovation(生物创新) . Together with customers across a broad array of industries we create tomorrow's industrial biosolutions, improving our customers' business and the use of our planet's resources. With over 700 products used in 130 countries, Novozymes' bioinnovations improve industrial performance and safeguard the world's resources by offering superior and sustainable solutions for tomorrow's ever changing marketplace.

The company is committed to nothing less than changing the very foundations of our industrial system for the better. By addressing industry challenge, we develop improved bio innovation solutions for detergents (清洁剂、去垢剂), pharmaceutical

(制药的) products, the chemical and energy sector, and countless other industries. The specific vision of the BioAg Group within Novozymes is to utilize microbial-based(微生物的, 由细菌引起的) technologies to help the world's farmers produce more and better food, feed, fuel, and fiber while minimizing the consumption of environmental resources.

Our core business is industrial enzymes (生化酶), microorganisms, and biopharmaceutical ingredients (生物制药的成分). Behind every enzyme product launched at Novozymes lies the discovery of an enzyme in nature, the engineering of the enzyme to make the best possible product, and finally the expression of genes in a microorganism.

We have three core technology platforms: biofertility, biocontrol, and bioyield enhancer. By using biotechnology we believe that we can potentially reengineer thousands of everyday products to deliver enhanced performance on a sustainable basis, at no extra cost. Novozymes' biological solutions enable everything from the removal of trans fats in food to advancements in renewable energy sources. Our never-ending exploration of nature's potential is evidenced by over 6,000 patents—the highest number of filed patents within bio innovation in the E.U.

Our corporation's promise is to "Rethink Tomorrow." By living this promise our research, production, and marketing groups will make the uncommon connections to get more from less and help your business grow through bioinnovation. Our internal goal is to challenge conventions, see things that others do not see, and as a result, create the next generation of ideas. Thus, Novozymes invests 14% of revenue in research and development. Enzymes receive the bulk of our research resources, while the balance is used for microorganisms and other areas outside enzymes. In these areas we leverage our biotech competencies and technologies to deliver solutions to—among others—the biopharmaceutical industry. Using our existing competencies, we are exploring new business opportunities based on our core technologies: fermentation, and the production of proteins.

Our research and development efforts are based on the latest thinking, newest technologies, and most efficient world-class organization techniques. Through close collaborations with customers and partners we deploy our methods and talent base to develop innovative products. Our cross-functional approach and world-class technology base mean that we are often able to apply the latest developments from one industry or area to overcome challenges in another. And by building on our

cross-industry insights we can best anticipate the future needs of our customers.

We know that we cannot institute change on a global scale in isolation, therefore, central to our strategy is a dedication to driving change in close alliance with our customers. By combining our biotechnology with our customers' industry insights, we are truly able to improve product performance while reducing environmental impact in a whole host of categories. We support our business associates and customers (distributors, retailers and farmers) with unparalleled service and support from the lab to the field to ensure maximum benefit is achieved when incorporating our biobased tools into an agronomic program. We achieve this customer service goal by serving our customers in every country in which the BioAg Group is present, with on-the-ground agronomic expertise for technical product and sales support.

Novozymes offers sustainable solutions that help our customers produce more with less, thereby reducing consumption of the world's resources. More specifically, we help our customers succeed today while at the same time preparing for the inevitable requirements of tomorrow by:

Translating reduced consumption of environmental resources and chemicals into customer claims

Responding to retailers' toughened sustainability requirements Responding to the stronger environmental regulation at political level

Supporting the achievement of our customers' internal sustainability goals.

The facts speak for themselves: Every major innovation in enzymes over the course of the last 40 years has been achieved by Novozymes. Our 5,000 employees working in research, production, and sales around the world are committed to shaping the businesses of today and the world of tomorrow.

Task: Search for useful information in the passage and complete the summary below. Fill in each blank with NO MORE THAN THREE WORDS.

Novozymes Profile

With over 1. _____ products used in 130 countries, Novozymes has improved bioinnovation solutions for 2. _____, pharmaceutical products, the chemical and energy sector, and countless other industries. The vision of their company is to utilize 3. _____ to help farmers produce more and better, while 4. _____ the consumption of environmental resources. Their main business covers 5. _____, microorganisms, and biopharmaceutical ingredients, and there are three core technology platforms including biofertility,

6. _____, and bioyield enhancer. Their corporation's promise is to "Rethink Tomorrow", with 14% of revenue invested in 7. _____. Their central strategy is to keep close alliance with their customers by combining their 8. _____ with customers' industry insights to improve product performance. Over the course of the last 40 years, they have 9. _____ employees working in research, 10. _____, and sales around the world to shape the business of today and the world of tomorrow.

任务 2：商务文书翻译(50 分)

内容：商务文书翻译

要求：阅读并理解所给商务文书；译文表达专业、术语准确，符合商务文体特征；内容完整，逻辑严谨，衔接流畅。

Section II 商务文书翻译(50 分)

Directions: Translate the following product description into Chinese.

Tide (汰渍) Washing Powder

Product dimensions: 5×5×5 inches

Weight: 2.64 pounds

Product Description:

Does not irritate (刺激) sensitive skin; non-toxic (无毒) and safe; for high efficiency washing machines. When filling the washer with water, add the powder, and then add the clothing. This helps ensure that the powder is dissolved (溶解) and properly distributed in the wash water. This washing powder is concentrated formula (配方) so you can use 1/3 less than previous non-concentrated formula and get the same great Tide clean.

(2) 实施条件

项目	基本实施条件	备注
场地	每个商务英语实训室配置 40 个操作台面和座位,每个实训室照明通风良好。	必备
设备	每个商务英语实训室配有 1 台服务器、40—50 台计算机,并安装 Office 办公软件,配置局域网。	必备

测评专家	每 40 名考生配备 1 名考评员。考评员要求具备至少二年以上从事国际贸易工作经验或三年以上商务英语实践教学指导经历。	必备
------	---	----

(3) 考核时量

考试时间：60 分钟

(4) 评分标准

模块总分	评价内容	配分	考核点	备注	
专业基本技能模块一：英语语言应用（总分 100 分，占总评分的 30%）	职业素养与操作规范（10 分）	2 分	(1) 具备外贸从业人员基本素质，认真严谨、耐心细致、恪守信誉、实事求是、服从安排，听从指挥、举止文明，记 2 分。	在考试过程中不服从安排、举止不当者，记 0 分。	
		2 分	(2) 具备外贸从业人员良好的翻译素养，认真严谨，耐心细致，记 2 分。	考试过程中出现与上述能力及素养不符，扣 1-2 分。	
		2 分	(3) 具备外贸从业人员良好的沟通能力、表达能力和合作意识，待人真诚礼貌，记 2 分。	考试过程中出现与上述能力及素养不符，扣 1-2 分。	
		2 分	(1) 具备使用办公设备和 Office 办公软件的能力，在考核过程中以及考核结束后，不私自更换电脑、不随意关闭或重启电脑，没征求监考老师同意不随意提前或推迟交卷，记 2 分。	若私自更换电脑、随意关闭或重启电脑，记 0 分。	
		2 分	(2) 能严格遵守企业 6S 管理要求（整理、整顿、清扫、清洁、素养、安全），记 2 分。	若未遵守企业 6S 管理要求，记 0 分。	
		10 分	(1) 阅读并理解所给外贸公司介绍资料，检索、筛选有效信息，记 10 分。		
	作品（90 分）	国际商务信息检索（40 分）	30 分	(2) 补充完善信息要点，每空不超过 3 个单词，每空 3 分，共 10 空，记 30 分。	大小写错误每处扣 0.5 分；答案不完整每处扣 1 分；拼写错误每处计 0 分
			15 分	(1) 能准确理解所给商务文书，语义信息理解正确，内容完整，记 15 分。	主要内容每缺失 1 处，扣 2 分
		商务文书翻译（50 分）	15 分	(2) 能熟练运用商务翻译技巧、国际贸易和英语语言综合知识，语言表达通顺，符合商务文体特征，记 15 分。	专业术语、贸易惯例、法规、条款等翻译错误，每 2 处错误扣 1 分。

		10分	(3) 语言表达通顺，语法、句型使用正确，记10分。	单词、语法每错3处扣1分。
		10分	(4) 译文表达准确，双语转换顺畅，体裁运用恰当，标点运用正确，记10分。	错别字、标点、句型表达，每2处错误扣1分。

7. 试题编号：1-1-7 国际商务信息检索与商务文书翻译

(1) 任务描述

任务 1：国际商务信息检索(40分)

内容：关键词检索

要求：阅读并理解所给信息；检索并筛选有效信息；补充完善信息要点。

Section I 国际商务信息检索(40分)

Directions: Read the following brief introduction to Kraft Foods from the official website of the company.

A Brief Introduction to Kraft Foods

Northfield, Illinois-based Kraft Foods Inc. (NYSE: KFT) is a global snacks powerhouse with an unrivaled portfolio of brands people love. Proudly marketing delicious biscuits, beverages, cheese, grocery products and convenient meals in approximately 170 countries, Kraft Foods had 2010 revenue of \$49.2 billion, more than half of which was earned outside North America. Eleven of the company's iconic brands – including Cadbury, Jacobs, Kraft, LU, Maxwell House, Milka, Nabisco, Oreo, Oscar Mayer, Philadelphia and Trident—generate revenue of more than \$1 billion annually, and 40 have been loved for more than a century. A leader in innovation, marketing, health & wellness and sustainability, Kraft Foods is a member of the Dow Jones Industrial Average.

Kraft Foods has two main operating units—Kraft Foods North America (KFNA; generating 73 percent of 2000 proforma revenues) and Kraft Foods International (KFI; 27 percent)—and its brands are divided into five main sectors: snacks (30.6 percent of global revenues; 28 percent of KFNA revenues; 38 percent of KFI revenues), beverages (global, 19 percent; KFNA, 13 percent; KFI, 35 percent), cheese (global,

18 percent; KFNA, 20 percent; KFI, 13 percent), grocery (global, 16.6 percent; KFNA, 19 percent; KFI, 10 percent), and convenient meals (global, 15.8 percent; KFNA, 20 percent; KFI, 4 percent). Seven of Kraft's brands bring in more than \$1 billion in revenues each year: Kraft cheeses and other products (\$4.3 billion in 2000 revenue), Nabisco cookies and crackers (\$3.5 billion), Oscar Mayer processed meats (number one in the United States), Post cereals (number three in the United States), Maxwell House coffee, Philadelphia cream cheeses, and Jacobs coffee (number one in western Europe). More than 60 company brands generate annual revenue in excess of \$100 million, including A.1. steak sauce, Altoids candy, Balance energy bars, Cheez Whiz process cheese sauce, Cool Whip whipped toppings, DiGiorno pizza, Freia confectionery, Gevalia coffee, Jell-O desserts, Kool-Aid drink mix, Life Savers candy, Miracle Whip dressing, Oreo cookies, Planters nuts, Premium crackers, Ritz crackers, Stove Top stuffing mix, Tang drink mix, and Toblerone chocolate. The company holds the top global position in 11 product categories: coffee, cookies, crackers, cream cheese, dessert mixes, dry packaged dinners, lunch combinations, powdered soft drinks, process cheese, salad dressings, and snack nuts. Kraft Foods' products are made at more than 220 manufacturing facilities around the world and are sold in more than 140 countries.

Now Kraft Foods is the largest food company in the United States and holds the number two position worldwide, behind Nestlé S.A. The complementary nature of our portfolio is at the heart of the three strategies that drive our growth. Delivering on the following strategies will put us in the top tier of our peer group and provide our shareholders with top-tier returns on their investment:

Delight global snacks consumers. Consumers around the world are pressed for time and are looking for on-the-go options. They're also looking for simple indulgences and healthier options. And there's nothing better than a delicious snack, like LU biscuits, Planters nuts, Trident gums, and Cadbury or Milka chocolates to satisfy those desires.

Unleash the power of our iconic heritage brands. Our iconic heritage brands are loved by consumers worldwide. Roughly 80 percent of these heritage brands hold number one or number two positions in their respective categories and are household names. Whether it's regional brands, like Philadelphia cream cheese in Europe and Tang powdered beverages in Asia Pacific; or local favorites like, A-1 sauces in the US and Vegemite spread in Australia, we make delicious products for billions of

consumers every day.

Create a performance-driven, values-led organization. To win in the market, we need to win with our customers and consumers, and with our colleagues, communities and suppliers. We'll live our values: We inspire trust; We act like owners; We keep it simple; We are open and inclusive; We tell it like it is; We lead from the head and the heart; We discuss, We decide, We deliver.

At Kraft Foods, we're always hungry to find new ways to grow our business. And we know that one of the ingredients of our success is our people. That's why we are committed to developing our people and helping them reach their potential. All of our employees have an opportunity to affect change, working with suppliers, customers and consumers to create a safer, more sustainable and delicious community.

Task: Search for useful information in the passage and complete the summary below. Fill in each blank with NO MORE THAN THREE WORDS.

Kraft Foods Profile

Kraft Foods, Inc. is a global 1. _____ with an unrivaled portfolio of brands people love. The company is headquartered in 2. _____, Illinois. It 3. _____ markets many brands in approximately 170 countries and has iconic brands generating revenue of over 4. _____ annually, including Cadbury, Jacobs, Kraft, LU, Maxwell House, Milka, 5. _____, Oreo, Oscar Mayer, Philadelphia and Trident. It is the second largest food company in the world after 6. _____. Kraft conducts its global food business through two main operating units, Kraft Foods North America and 7. _____. These two units participate in five core consumer sectors: snacks, beverages, cheese, grocery and 8. _____. Company holds the top global position in 11 product categories: coffee, cookies, crackers, 9. _____, dessert mixes, dry packaged dinners, lunch combinations, powdered soft drinks, process cheese, salad dressings, and snack nuts. There are three strategies that drive its growth, namely, delight global snacks consumers, unleash the power of its iconic heritage brands, and create a 10. _____, values-led organization.

任务 2: 商务文书翻译(50 分)

内容: 商务文书翻译

要求: 阅读并理解所给商务文书; 译文表达专业、术语准确, 符

合商务文体特征；内容完整，逻辑严谨，衔接流畅。

Section II 商务文书翻译(50分)

Directions: Translate the following advertisement into Chinese.

Happiness Coffeemaker
The Happiness Coffeemaker introduces an evolutionary new look in coffeemakers. Its bright red makes it a brilliant new addition to any kitchen. Fully programmable(程序化) from start to finish, with adjustable Keep Warm temperature control, 1-4 cup setting, adjustable auto shutoff from 0 to 4 hours and a self-clean indicator(指示器), it's the ideal coffeemaker for today's demanding(要求高的/苛刻的) consumer. It is simple and easy to use. Happiness coffeemaker, your best choice!

(2) 实施条件

项目	基本实施条件	备注
场地	每个商务英语实训室配置 40 个操作台面和座位,每个实训室照明通风良好。	必备
设备	每个商务英语实训室配有 1 台服务器、40—50 台计算机,并安装 Office 办公软件,配置局域网。	必备
测评专家	每 40 名考生配备 1 名考评员。考评员要求具备至少二年以上从事国际贸易工作经验或三年以上商务英语实践教学指导经历。	必备

(3) 考核时量

考试时间：60 分钟

(4) 评分标准

模块总分	评价内容	配分	考核点	备注
专业基本技能模块	职业素养与操作规范(10分)	2分	(1) 具备外贸从业人员基本素质,认真严谨、耐心细致、恪守信誉、实事求是、服从安排,听从指挥、举止文明,记 2 分。	在考试过程中不服从安排、举止不当者,记 0 分。
		2分	(2) 具备外贸从业人员良好的翻译素养,认真严谨,耐心细致,记 2 分。	考试过程中出现与上述能力及素养不符,扣 1-2 分。

一： 英 语 语 言 应 用 (总 分 100 分，占 总 评 分 的 30%)		2 分	(3)具备外贸从业人员良好的沟通能力、表达能力和合作意识，待人真诚礼貌，记 2 分。	考试过程中出现与 所述能力及素养不 符，扣 1-2 分。	
		操作 规范 (4 分)	2 分	(1) 具备使用办公设备和 Office 办公软件的能力，在考核过程中以及考核结束后，不私自更换电脑、不随意关闭或重启电脑，没征求监考老师同意不随意提前或推迟交卷，记 2 分。	若私自更换电脑、 随意关闭或重启电 脑，记 0 分。
			2 分	(2) 能严格遵守企业 6S 管理要求（整理、整顿、清扫、清洁、素养、安全），记 2 分。	若未遵守企业 6S 管理要求，记 0 分。
	作品 (90 分)	国际 商务 信息 检索 (40 分)	10 分	(1)阅读并理解所给外贸公司介绍资料，检索、筛选有效信息，记 10 分。	
			30 分	(2) 补充完善信息要点，每空不超过 3 个单词，每空 3 分，共 10 空，记 30 分。	大小写错误每处扣 0.5 分；答案不完 整每处扣 1 分；拼 写错误每处计 0 分
		商务 文书 翻译 (50 分)	15 分	(1) 能准确理解所给商务文书，语义信息理解正确，内容完整，记 15 分。	主要内容每缺失 1 处，扣 2 分
			15 分	(2) 能熟练运用商务翻译技巧、国际贸易和英语语言综合知识，语言表达通顺，符合商务文体特征，记 15 分。	专业术语、贸易惯 例、法规、条款等 翻译错误，每 2 处 错误扣 1 分。
			10 分	(3) 语言表达通顺，语法、句型使用正确，记 10 分。	单词、语法每错 3 处扣 1 分。
			10 分	(4) 译文表达准确，双语转换顺畅，体裁运用恰当，标点运用正确，记 10 分。	错别字、标点、句 型表达，每 2 处错 误扣 1 分。

8. 试题编号：1-1-8 国际商务信息检索与商务文书翻译

(1) 任务描述

任务 1：国际商务信息检索(40 分)

内容：关键词检索

要求：阅读并理解所给信息；检索并筛选有效信息；补充完善信息要点。

Section I 国际商务信息检索(40分)

Directions: Read the following brief introduction to Whole Foods Market from the official website of the company.

A Brief Introduction to Whole Foods Market

Whole Foods Market is committed to being the best in the world and is in fact the world's leader in natural and organic foods, with more than 300 stores in North America and the United Kingdom. In 2004, according to the Financial Times, Whole Foods Market was "the fastest-growing mass retailer in the U.S.A., with same-store sales rising 17.1 per cent quarter-on-quarter."

Our founders were John Mackey and Renee Lawson Hardy, owners of Safer Way Natural Foods, and Craig Weller and Mark Skiles, owners of Clarksville Natural Grocery. In 1978, twenty-five year old college dropout John Mackey and twenty-one year old Rene Lawson Hardy, borrowed \$45,000 from family and friends to open the doors of a small natural foods store called SaferWay in Austin, Texas. Two years later, John and Rene partnered with Craig Weller and Mark Skiles to merge SaferWay with their Clarksville Natural Grocery, resulting in the opening of the original Whole Foods Market on September 20, 1980. At 10,500 square feet and a staff of 19, this store was quite large in comparison to the standard health food store of the time. It was an immediate success. We have grown by leaps and bounds since our first store opened. Much of the growth of our company has been accomplished through mergers and acquisitions, with approximately 32% of its existing square footage coming from take-over's. These mergers and acquisitions have provided us access to desirable markets, locations and experienced team members.

We sell an average of 20,000 food and non-food items with a heavy emphasis on perishable foods designed to appeal to both natural, organic, and gourmet shoppers. We offer a broad product selection in all its stores, including seafood, grocery, meat and poultry, bakery, prepared foods, specialty (beer, wine and cheese), whole body (nutritional supplements, vitamins, body care and educational products such as books), floral, pet products and household products. In our larger stores (between 60,000 to 80,000 square feet), we stock an even larger selection of organic food and non-food products. These stores also have catering services where customers can purchase made-to-order foods. Wide product portfolio allows us address multiple customer segments, apart from insulating it from any significant fall in demand for any specific product or segment.

Our emphasis on fresh food gives the company an edge over its competitors who usually just offer packaged foods. We search for the highest quality, least processed, most flavorful and natural foods possible because we believe that food in its purest state — unadulterated by artificial additives, sweeteners, colorings and preservatives — is the best tasting and most nutritious food there is. We define quality by evaluating the ingredients, freshness, safety, taste, nutritive value and appearance of all of the products. We are buying agents for our customers and not the selling agents for the manufacturers. To be specific, our quality goals and standards include evaluating every product sold; carrying featured and prepared foods free from artificial preservatives, colors, flavors, and sweeteners; a passion for great tasting food and for sharing it with each other; a commitment to foods that are fresh, wholesome, and safe to eat; using no genetically-modified organisms in our private-label products; seeking out and supporting sources of organically-grown foods; maintaining that seafood, poultry, and meat are free of added growth hormones, antibiotics, nitrates, or other chemicals; and featuring grains and grain products that have not been bleached or bromated. We do not sell food that has been irradiated and sell only household and personal products that have been proven safe through non-animal testing methods.

We go to extraordinary lengths to satisfy and delight our customers, for they are our most important stakeholders in our business and the lifeblood of our business. We want to meet or exceed their expectations on every shopping trip. We know that by doing so we turn customers into advocates for our business. Advocates do more than shop with us; they talk about Whole Foods Market to their friends and others. We want to serve our customers competently, efficiently, knowledgeably and with flair.

Our success is dependent upon the collective energy and intelligence of all of our team members. The fundamental work unit of the company is the self-directed team. Teams meet regularly to discuss issues, solve problems and appreciate each others' contributions. Every team member belongs to a team. We strive to create a work environment where motivated team members can flourish and succeed to their highest potential. In this way, many people feel Whole Foods Market is an exciting company of which to be a part and a very special place to work.

Task: Search for useful information in the passage and complete the summary below. Fill in each blank with NO MORE THAN THREE WORDS.

Whole Foods Market Profile

Whole Foods Market is the world's leader in 1. _____ foods

foods, with over than 300 stores in 2._____ and the United Kingdom. Their founders were John Mackey and Renee Lawson Hardy, owner of Safer Way Natural Foods, and Craig Weller and Mark Skiles, owners of 3._____. The original Whole Foods Market started in 1980, at 10,500 square feet and a staff of 4._____. Since then, it has developed incredibly rapidly, much of which has been achieved through 5._____. Now it sells an average of 6._____ food and non-food items, including seafood, 7._____, meat and poultry, bakery, prepared foods, specialty, whole body, floral, 8._____ and household products. In its larger stores, catering services are provided for customers with 9._____. In all, its success relies on the 10._____ and intelligence of all of its team members.

任务 2: 商务文书翻译(50 分)

内容: 商务文书翻译

要求: 阅读并理解所给商务文书; 译文表达专业、术语准确, 符合商务文体特征; 内容完整, 逻辑严谨, 衔接流畅。

Section II 商务文书翻译(50 分)

Directions: Translate the following advertisement into Chinese.

Job Wanted

In order to open up overseas markets, our company needs qualified international trade salespersons. The candidates(面试者) should be familiar with business knowledge, business negotiation skills, and good abilities of listening, speaking, reading, writing, and translating. Good communication ability and tremendous working enthusiasm are also the ideal qualities for our candidates. Those who have working experience may receive preference. For more details please call at 12345678.

Hunan Cereals, Oils and Foodstuffs(粮油食品)

Import and Export Group Corp. Ltd.

(2) 实施条件

项目	基本实施条件	备注
场地	每个商务英语实训室配置 40 个操作台面和座位, 每	必备

	个实训室照明通风良好。	
设备	每个商务英语实训室配有 1 台服务器、40—50 台计算机，并安装 Office 办公软件，配置局域网。	必备
测评专家	每 40 名考生配备 1 名考评员。考评员要求具备至少二年以上从事国际贸易工作经验或三年以上商务英语实践教学指导经历。	必备

(3) 考核时量

考试时间：60 分钟

(4) 评分标准

模块总分	评价内容	配分	考核点	备注	
专业基本技能模块一：英语语言应用（总分 100 分，占总评分的 30%）	职业素养与操作规范（10 分）	2 分	(1) 具备外贸从业人员基本素质，认真严谨、耐心细致、恪守信誉、实事求是、服从安排，听从指挥、举止文明，记 2 分。	在考试过程中不服从安排、举止不当者，记 0 分。	
		2 分	(2) 具备外贸从业人员良好的翻译素养，认真严谨，耐心细致，记 2 分。	考试过程中出现与上述能力及素养不符，扣 1-2 分。	
		2 分	(3) 具备外贸从业人员良好的沟通能力、表达能力和合作意识，待人真诚礼貌，记 2 分。	考试过程中出现与上述能力及素养不符，扣 1-2 分。	
	操作规范（4 分）	2 分	(1) 具备使用办公设备和 Office 办公软件的能力，在考核过程中以及考核结束后，不私自更换电脑、不随意关闭或重启电脑，没征求监考老师同意不随意提前或推迟交卷，记 2 分。	若私自更换电脑、随意关闭或重启电脑，记 0 分。	
		2 分	(2) 能严格遵守企业 6S 管理要求（整理、整顿、清扫、清洁、素养、安全），记 2 分。	若未遵守企业 6S 管理要求，记 0 分。	
	作品（90 分）	国际商务信息检索（40 分）	10 分	(1) 阅读并理解所给外贸公司介绍资料，检索、筛选有效信息，记 10 分。	
			30 分	(2) 补充完善信息要点，每空不超过 3 个单词，每空 3 分，共 10 空，记 30 分。	大小写错误每处扣 0.5 分；答案不完整每处扣 1 分；拼写错误每处计 0 分
		商务文书	15 分	(1) 能准确理解所给商务文书，语义信息理解正确，内容完整，记 15 分。	主要内容每缺失 1 处，扣 2 分

	翻译 (50分)	15分	(2) 能熟练运用商务翻译技巧、国际贸易和英语语言综合知识, 语言表达通顺, 符合商务文体特征, 记15分。	专业术语、贸易惯例、法规、条款等翻译错误, 每2处错误扣1分。
		10分	(3) 语言表达通顺, 语法、句型使用正确, 记10分。	单词、语法每错3处扣1分。
		10分	(4) 译文表达准确, 双语转换顺畅, 体裁运用恰当, 标点运用正确, 记10分。	错别字、标点、句型表达, 每2处错误扣1分。

9. 试题编号: 1-1-9 国际商务信息检索与商务文书翻译

(1) 任务描述

任务 1: 国际商务信息检索(40分)

内容: 关键词检索

要求: 阅读并理解所给信息; 检索并筛选有效信息; 补充完善信息要点。

Section I 国际商务信息检索(40分)

Directions: Read the following brief introduction to Charoen Pokphand Group (泰国正大集团) from the official website of the company.

A Brief Introduction to Charoen Pokphand Group

Charoen Pokphand Group (CP Group) with headquarters in Bangkok, Thailand was founded in 1921 by the Chia brothers, and is today one of Asia's leading conglomerates. With businesses and affiliates operating within the agribusiness, retail and telecommunications markets, we currently employ over 250,000 people who conduct our investments, operations and trading at factories and offices worldwide. Our sales at the end of 2010 were USD 30 billion.

In 1921, Chia brothers, Ek Chor and Siew Whooy established a small seed shop named "Chia Tai" in Bangkok, Thailand. Their business was importing seeds from China for sale to Thai farmers. As produce from the seeds flourished, Chia Tai progressed towards the production of animal feed, allowing for the company to further integrate towards livestock farming(畜牧业). The completion of CP's fully integrated agribusiness (from seed to feed to food) is a combination of both

experience gained throughout the years, in parallel, with the addition of technological advances developed locally and acquired from abroad.

In our first 30 years of expansion, CP became the fifth largest feed mill (饲料加工厂) operator in the world, and by the 1990's, production reached an annual total of 14 million tons at its 144 mills in countries including India, China and United States. Today, as Charoen Pokphand Group continues to actively invest and operate in numerous industries across the world, agribusiness still is deeply rooted within the foundations of the organization as it branches further into the international markets. Today, it has grown into multinational enterprise, with more than 250 subsidiaries in 20 countries.

For more than 90 years, CP Group's operations and investments both locally and internationally have always contained our three-benefit philosophy. Passionately embedded into our everyday working life, our businesses and affiliates with more than 250,000 employees worldwide firmly uphold that our work must serve as a:

Benefit to the Country

Benefit to the People

Benefit to the Company.

At CP, through our companies and affiliates, we have committed ourselves to integrating social and environmental concerns in our everyday business whether it is locally or abroad. CP research teams comprise high caliber professionals who are highly regarded in agriculture industry. They cooperate with other outside parties, including research institutes both in Thailand and overseas, specialists, customers and various public agencies, with the mutual objective of sustaining the industry, while having business adhering to environmental friendliness.

Aside from developments for the sustainability of the overall industry, we emphasize product development to satisfy consumer requirements. Our quality cycle begins from the field to the consumer, along the whole production chain. The quality assurance activities are not only targeted food safety, but also food quality and nutritional value of products. These include raw material and supplier, during processing, transport and distribution of the finished products until consumer consumption. Manufacturing food products to meet the differing regulations and standards of each customer throughout the world, together with the company's ability to develop products and improve its animal breeding process to meet international standards, have resulted in customers being confident that CP's products are of high

quality, tasty and safe for consumption.

CP is the first multinational enterprise to invest in China's agribusiness, in 1979. Serving the changing needs and demands of China's 1.3 billion people, CP businesses are involved with growing, processing and marketing of foods under its "farm-to-table integration strategy". CP has over 100 compounds feed mills and 5 fully integrated poultry (家禽) businesses in 29 of China's 31 provinces, autonomous regions and municipalities. It has opened seed shops and arranged seminars in villages across China, in order to improve farming methods and add to the profitability of China's farmers. The importance of bio-security and food safety is paramount to the production of both human and animal food. CP's technical service teams of veterinarians and animal husbandry specialists, provide farmers with advice and support. More than one-quarter of China's poultry exports comes from CP's integrated poultry business. In 2009, Charoen Pokphand Group through its Chia Tai, its business arm in China, has been ranked as one of the best 500 companies of overseas Chinese investors, reporting total income reached RMB 49.42 billion or Bt247.11 billion with average business growth achieved 17.65 percent in 2008. Its total assets was reported RMB 30.35 billion or Bt151.75 billion involving in farm, fishery, seed, food, petroleum, motorcycle, property, medicine, retail and international trade.

Task: Search for useful information in the passage and complete the summary below. Fill in each blank with NO MORE THAN THREE WORDS.

Charoen Pokphand Group Profile

Headquartered in 1. _____, Thailand, Charoen Pokphand Group (CP Group) was founded in 1921. Today, it has over 2. _____ employees and operates in the agribusiness, retail and 3. _____ markets. The Chia brothers start their business with a 4. _____ called "Chia Tai". Later, it developed towards the production of 5. _____ and further integrated towards livestock farming. Over thirty years' expansion, it has become 6. _____ feed mill operator in the world. Charoen Pokphand Group is also the first multinational corporation to invest in China's 7. _____, in 1979. Since then, it has had more than 100 compounds feed mills and 5 fully 8. _____ in 29 of China's 31 provinces, autonomous regions and municipalities. Its total assets was reported 9. _____ RMB30.35 billion or Bt151.75 billion involving in farm, fishery, seed, food, petroleum, motorcycle, 10. _____, medicine, retail and international trade.

任务 2: 商务文书翻译(50 分)

内容: 商务文书翻译

要求: 阅读并理解所给商务文书; 译文表达专业、术语准确, 符合商务文体特征; 内容完整, 逻辑严谨, 衔接流畅。

Section II 商务文书翻译(50 分)

Directions: Translate the following product description into Chinese.

Characteristics of the Product

1. Rich in vitamins, microelements, amino acids(氨基酸), fish powder, growth promoting agent, acidulant(酸化剂), environment-protection preventive medicine additive, etc.

2. Good in palatability(适口性). Because of this, pigs like to eat and sleep well after eating it. The fur of the pigs will be shiny and the skin will be rosy after 3-7 days' feeding.

3. High in survival rate, easy to raise, uneasy to fall ill, rapid in growth, well-proportioned in body.

(2) 实施条件

项目	基本实施条件	备注
场地	每个商务英语实训室配置 40 个操作台面和座位, 每个实训室照明通风良好。	必备
设备	每个商务英语实训室配有 1 台服务器、40—50 台计算机, 并安装 Office 办公软件, 配置局域网。	必备
测评专家	每 40 名考生配备 1 名考评员。考评员要求具备至少二年以上从事国际贸易工作经验或三年以上商务英语实践教学指导经历。	必备

(3) 考核时量

考试时间: 60 分钟

(4) 评分标准

模块总分		评价内容	配分	考核点	备注
专业基本技能模块一：英语应用（总分100分，占总评分的30%）	职业素养与操作规范（10分）	职业素养（6分）	2分	（1）具备外贸从业人员基本素质，认真严谨、耐心细致、恪守信誉、实事求是、服从安排，听从指挥、举止文明，记2分。	在考试过程中不服从安排、举止不当者，记0分。
			2分	（2）具备外贸从业人员良好的翻译素养，认真严谨，耐心细致，记2分。	考试过程中出现与上述能力及素养不符，扣1-2分。
			2分	（3）具备外贸从业人员良好的沟通能力、表达能力和合作意识，待人真诚礼貌，记2分。	考试过程中出现与上述能力及素养不符，扣1-2分。
		操作规范（4分）	2分	（1）具备使用办公设备和 Office 办公软件的能力，在考核过程中以及考核结束后，不私自更换电脑、不随意关闭或重启电脑，没征求监考老师同意不随意提前或推迟交卷，记2分。	若私自更换电脑、随意关闭或重启电脑，记0分。
			2分	（2）能严格遵守企业 6S 管理要求（整理、整顿、清扫、清洁、素养、安全），记2分。	若未遵守企业 6S 管理要求，记0分。
	作品（90分）	国际商务信息检索（40分）	10分	（1）阅读并理解所给外贸公司介绍资料，检索、筛选有效信息，记10分。	
			30分	（2）补充完善信息要点，每空不超过3个单词，每空3分，共10空，记30分。	大小写错误每处扣0.5分；答案不完整每处扣1分；拼写错误每处计0分
		商务文书翻译（50分）	15分	（1）能准确理解所给商务文书，语义信息理解正确，内容完整，记15分。	主要内容每缺失1处，扣2分
			15分	（2）能熟练运用商务翻译技巧、国际贸易和英语语言综合知识，语言表达通顺，符合商务文体特征，记15分。	专业术语、贸易惯例、法规、条款等翻译错误，每2处错误扣1分。
			10分	（3）语言表达通顺，语法、句型使用正确，记10分。	单词、语法每错3处扣1分。
			10分	（4）译文表达准确，双语转换顺畅，体裁运用恰当，标点运用正确，记10分。	错别字、标点、句型表达，每2处错误扣1分。

10. 试题编号：1-1-10 国际商务信息检索与商务文书翻译

（1）任务描述

任务 1：国际商务信息检索(40 分)

内容：关键词检索

要求：阅读并理解所给信息；检索并筛选有效信息；补充完善信息要点。

Section I 国际商务信息检索(40 分)

Directions: Read the following brief introduction to Probiotec Limited from the official website of the company.

A Brief Introduction to Probiotec Limited

Established in 1997 as a single site operation, Probiotec Limited has a reputation for innovation and rapid response to market opportunities. Its growth has been fuelled by strong organic growth and strategic acquisitions along with relationships and joint ventures with global market participants that want to conduct business with a company that maintains high levels of quality and innovation.

Since beginning operations in 1997, Probiotec Limited has quickly emerged as a leading manufacturer, marketer and distributor of a diverse, high quality range of prescription and over-the-counter (OTC) pharmaceuticals (医药品), complementary medicines and specialty ingredients. Our proven experience and expertise extend across a wide range of healthcare goods – offering you access to the cost efficient contract manufacturer of existing Probiotec Limited formulations, new custom developed formulations (or formulations which you already possess and wish to produce) in any of the following categories: Prescription and OTC Pharmaceuticals, Nutraceuticals and Cosmeceuticals, Human Nutrition (including dairy based powders and sports nutrition products), Animal Nutrition(Feed Supplements), and High Purity Functional Ingredient.

What separates Probiotec Limited from other trusted contract manufacturers is not only that we invest so heavily on Research and Development; equip our five production facilities with the latest new technologies; employ chemists and microbiologists of the highest calibre and maintain Quality Assurance standards that are second to none, but we also manufacture and market our own products. As a result, we have a full understanding of the process and dynamics of developing formulations (and brands) for the retail market that deliver margins to optimize

return-on-investment.

Probiotec Limited's brands are stocked in a wide variety of pharmacies, health food stores and major supermarkets across Australia but for customers who prefer the convenience of purchasing online, our products are also available from our online store www.pharmaonline.com.au. Through Pharma Online, customers can take advantage of our everyday low prices on a selection of tried and tested pharmaceutical and consumer health products.

Celebrity Slim

This meal replacement program has gained rapid acceptance among people wanting to achieve and sustain weight loss. Celebrity Slim adds the important personal touch of educating consumers in a consultation environment. This winning approach has been achieved through a unique partnership with a major retail chain.

BioSource

BioSource is a premium range of vitamin and nutritional supplements developed by Pharmacists that contain clinically researched and naturally based ingredients. It aims to improve people's health and wellbeing through education and awareness about various conditions, lifestyle and diet factors.

Milton

Since acquiring this market-leading brand, Probiotec Limited continues to build on the trusted reputation Milton has established in antibacterial hygiene over many generations. Today, the brand remains a firm favorite for baby care, home and professional use.

Gold Cross

Available only through pharmacies, it provides a range of effective traditional medicines at real value for money prices. It includes remedies for coughs & colds, skin care, arthritis & pain, wound management, as well as vitamin supplements and general medicines.

David Craig

A trusted name among healthcare professionals since 1942, our David Craig brand continues to provide pharmacy dispensaries with galenical products (compounding materials and preparations) and skin care formulations of uncompromising quality.

Skin Basics

This successful skincare brand delivers an excellent range of gentle, soap-free

cleansing, moisturizing and protective formulations for dry skin conditions.

Arthroflex MAX

Arthroflex MAX is an easy to drink, one sachet serve per day supplement for managing the symptoms of Arthritis and Osteoarthritis. Containing Glucosamine, Chondroitin Sulphate, Ascorbic Acid (vitamin C) and Manganese, it provides a pleasant alternative to taking tablets.

Slimmm

It has been carefully designed to fit our modern lifestyle and help you with a nutritious, well balanced, scientifically based, effective weight management program. Slimmm is a Meal Replacement Program which recommends you eat 3 meals and 3 snacks a day and enjoy a breakout day once a week, where you eat a normal moderate diet. This day allows you to enjoy social occasions with family or friends once a week while staying within the program guidelines.

Palastart & Palabind

As a leading supplier of nutritional feed supplements for animals, Probiotec Limited offer breeders and farmers everything from Milk Replacer products for calves, blue calves, lambs and kids to Molasses Powder and Horse Treats under the Palastart and Palabind brands.

Task: Search for useful information in the passage and complete the summary below. Fill in each blank with NO MORE THAN THREE WORDS.

Probiotec Limited Profile

Since beginning operations in 1. _____, Probiotec Limited is well-known for its 2. _____ and rapid response to market opportunities. Its development has been facilitated by strong organic growth and 3. _____ along with relationships and joint ventures with global market participants that want to conduct business with a company that maintains high levels of quality and innovation. It offers a diverse range of prescription and over-the-counter (OTC) pharmaceuticals, complementary medicines and 4. _____. What separates Probiotec Limited from others is not only our heavy investment on 5. _____, but they also 6. _____ their own products. Their brands are stocked in pharmacies, 7. _____ and major supermarkets across Australia. Their products are also available from their 8. _____ www.pharmaonline.com.au. Their branded products include Celebrity Slim, 9. _____, Milton, Gold Cross, David Craig, 10. _____, Arthroflex MAX, Slimmm, Palastart & Palabind.

任务 2: 商务文书翻译(50 分)

内容: 商务文书翻译

要求: 阅读并理解所给商务文书; 译文表达专业、术语准确, 符合商务文体特征; 内容完整, 逻辑严谨, 衔接流畅。

Section II 商务文书翻译(50 分)

Directions: Translate the following product description into Chinese.

This health-care food contains Vitamin C, Orange juice powder, Starch (淀粉), etc. It's a healthy food that can supply vitamin C.

Ingredients: Vitamin C, Orange juice powder, Starch, etc.

Function: Supply Vitamin C.

Active ingredient and content: Vitamin C: 100mg per pill.

Direction for Use: The average dose is 1 pill 3 times daily, orally.

Attention: This product cannot replace medicines. Please do not take more than recommended amount or with other nutrients supplement of the same type.

(2) 实施条件

项目	基本实施条件	备注
场地	每个商务英语实训室配置 40 个操作台面和座位, 每个实训室照明通风良好。	必备
设备	每个商务英语实训室配有 1 台服务器、40—50 台计算机, 并安装 Office 办公软件, 配置局域网。	必备
测评专家	每 40 名考生配备 1 名考评员。考评员要求具备至少二年以上从事国际贸易工作经验或三年以上商务英语实践教学指导经历。	必备

(3) 考核时量

考试时间: 60 分钟

(4) 评分标准

模块	评价	配分	考核点	备注
----	----	----	-----	----

总分		内容			
专业基本技能模块一：英语语言应用（总分100分，占总评分的30%）	职业素养与操作规范（10分）	职业素养（6分）	2分	（1）具备外贸从业人员基本素质，认真严谨、耐心细致、恪守信誉、实事求是、服从安排，听从指挥、举止文明，记2分。	在考试过程中不服从安排、举止不当者，记0分。
			2分	（2）具备外贸从业人员良好的翻译素养，认真严谨，耐心细致，记2分。	考试过程中出现与上述能力及素养不符，扣1-2分。
			2分	（3）具备外贸从业人员良好的沟通能力、表达能力和合作意识，待人真诚礼貌，记2分。	考试过程中出现与上述能力及素养不符，扣1-2分。
		操作规范（4分）	2分	（1）具备使用办公设备和 Office 办公软件的能力，在考核过程中以及考核结束后，不私自更换电脑、不随意关闭或重启电脑，没征求监考老师同意不随意提前或推迟交卷，记2分。	若私自更换电脑、随意关闭或重启电脑，记0分。
	2分		（2）能严格遵守企业 6S 管理要求（整理、整顿、清扫、清洁、素养、安全），记2分。	若未遵守企业 6S 管理要求，记0分。	
	作品（90分）	国际商务信息检索（40分）	10分	（1）阅读并理解所给外贸公司介绍资料，检索、筛选有效信息，记10分。	
			30分	（2）补充完善信息要点，每空不超过3个单词，每空3分，共10空，记30分。	大小写错误每处扣0.5分；答案不完整每处扣1分；拼写错误每处计0分
		商务文书翻译（50分）	15分	（1）能准确理解所给商务文书，语义信息理解正确，内容完整，记15分。	主要内容每缺失1处，扣2分
			15分	（2）能熟练运用商务翻译技巧、国际贸易和英语语言综合知识，语言表达通顺，符合商务文体特征，记15分。	专业术语、贸易惯例、法规、条款等翻译错误，每2处错误扣1分。
			10分	（3）语言表达通顺，语法、句型使用正确，记10分。	单词、语法每错3处扣1分。
			10分	（4）译文表达准确，双语转换顺畅，体裁运用恰当，标点运用正确，记10分。	错别字、标点、句型表达，每2处错误扣1分。

11. 试题编号：1-1-11 国际商务信息检索与商务文书翻译

（1）任务描述

任务 1：国际商务信息检索(40分)

内容：关键词检索

要求：阅读并理解所给信息；检索并筛选有效信息；补充完善信息要点。

Section I 国际商务信息检索(40分)

Directions: Read the following brief introduction to Onninen Group from the official website of the company.

A Brief Introduction to Onninen Group

Onninen Group provides comprehensive materials services to contractors, industry, public organizations and technical product retailers. We are a family-owned company and have operated in the industry since 1913. We offer products and services in the markets of Finland, Sweden, Norway, Poland, Russia, Estonia, Latvia, Lithuania and Kazakhstan. Our net sales for 2010 totaled EUR 1.4 billion.

History

The founder of Onninen Group, Mr. Alfred Onninen, started out as a plumbing contractor in Turku in 1913. In the 1920s the business diversified into heating and plumbing wholesale, gradually extending into different parts of Finland. The company went into ventilation and electrical contracting as well as wholesale of ventilation and electrical products more than 30 years ago.

Internationalization, which began in the 1970s in the form of project exports, has continued for more than a decade through organic growth and through acquisitions. As a result of reorganization at the end of the 1990s, Onninen gave rise to the Onvest Group.

Vision, Mission, Goals

The Onninen strategy can be compared to a house – with values as a solid foundation and a proven mission that makes up the cornerstones for setting the strategy and long-term goals.

The overall vision is to be the First Choice in material services for our customers and suppliers, as well as the First Choice as an employer.

Our mission is to provide technical goods and services in order to improve our customers' businesses with value adding business and service concepts. For our suppliers, we can provide a channel of products and information to their final customers. In essence, Onninen's business is about helping our customers focus on

their core business.

Our goals are also expressed as our Key Financial Targets for the next 3 – 5 years as follows:

annual growth in turnover of: over 10%

EBITA: over 5%

ROI: over 20%

Products

The Group product range comprises over 200.000 items of the leading suppliers.

Onninen has two own product brands, Onnline and OPAL.

Onnline - secure and safe choice for professionals; Onnline products and solutions are meant for professional use.

They are built to last.

The products are designed following the latest technological and environmental development.

OPAL - easy living for consumers.

OPAL products are quality products which are sold in retailer shops to consumers. OPAL products offer right selection of electrical and HEPAC products for active consumers. Reasonable price added to guaranteed quality makes OPAL the easy choice for many different requirements at home.

Services

Onninen Express

Onninen Express is our chain brand targeted to serve business-to-business customers. Express shops offer electrical, HEPAC, refrigeration, and other technical products.

You can easily pick up HEPAC sector's most commonly used daily products from these Express stores. You can also order products with quick delivery times from our warehouse collection through the Express stores. Our professional staff offers knowledgeable and reliable service.

E-commerce services

In all Onninen countries, customers are served electronically.

Onnshop

OnnShop is an online shop, which offers you all the Onninen warehouse products. Right product can be easily found with the help of the comprehensive search features. At the same time you will be able to see client specific net price and real

time availability of the product – 24 hours a day. OnnShop’s product data bank also offers technical information about the products.

Electrical Pricelists

We have product catalogues and price lists available to you. You can find the regularly updated electronic price lists, which can be downloaded onto your software.

Logistics Services

Distribution and warehousing are the basis of Onninen’s operations in all areas. Logistics have been organized locally in ways that serve different countries to ensure that customers’ daily needs are satisfied to the highest degree. Distribution centers are located in all Onninen countries i.e. in Finland, Sweden, Norway, Poland, Estonia, Latvia, Lithuania and Russia.

Logistics services include: for example, Onni Distribution, 24 hour service, Super fast delivery and Precision delivery.

Project services

We have strong experience and know-how in project management. We offer the benefits of a complete service: schedules are respected, entity is well coordinated, procurement is easy and high purchase volume offers cost benefits.

Information for suppliers

Onninen Group offers a comprehensive range of products in electrical, lighting, cables and utility, sanitary, heating and plumbing, ventilation and refrigeration, pipes and fittings, plastic and environmental, and steel to customer segments like

Contractors, Industry, Infrastructure and Retailers.

Onninen Group is looking for the best products at competitive prices for each market. The group-wide consolidation of suppliers and products by standardizing quality and utilizing TCO (Total Cost Ownership) thinking are key drivers of sourcing goals. We prefer long term cooperation with the suppliers sharing common understanding to develop the supply chain in our industry.

Onninen Group has a Group’s distribution network with Express shops and warehouses in nine countries. This provides an effective process from purchase to payment.

Task: Search for useful information in the passage and complete the summary below. Fill in each blank with NO MORE THAN THREE WORDS.

Onninen Group Profile

Established in 1. _____, Onninen Group is a family-owned company

which offers 2. _____ to contractors, industry, public organizations and retailers in the markets of 3. _____ countries. Onninen has two product brands of its own: Onnline for 4. _____ use, and 5. _____ for easy living of consumers. Customers of Onninen can either shop in an Onninen Express store, the company's 6. _____ targeted to serve business-to-business customers, or be served electronically in OnnShop, an 7. _____ that offers all the Onninen warehouse products. Onninen Group also offers logistics services and 8. _____. The company's total net sale for 2010 was 9. _____. It aims 10. _____ annual growth in turnover in the next 3 – 5 years.

任务 2：商务文书翻译(50 分)

内容：商务文书翻译

要求：阅读并理解所给商务文书；译文表达专业、术语准确，符合商务文体特征；内容完整，逻辑严谨，衔接流畅。

Section II 商务文书翻译(50 分)

Directions: Translate the following advertisement into Chinese.

Advertisement

In order to better open up our overseas markets, we now need a sole agent in South Africa with a lot of favorable terms. Our new sole agent should have been in the field of international trade for at least two years, and know clearly the international trade practices. The new agent's annual performance need to reach at least 1,000,000 USD, and our commission is at least 5% or more according to the performance. You are welcome to join us.

(2) 实施条件

项目	基本实施条件	备注
场地	每个商务英语实训室配置 40 个操作台面和座位,每个实训室照明通风良好。	必备
设备	每个商务英语实训室配有 1 台服务器、40—50 台计算机,并安装 Office 办公软件,配置局域网。	必备
测评专家	每 40 名考生配备 1 名考评员。考评员要求具备至	必备

	少二年以上从事国际贸易工作经验或三年以上商务英语实践教学指导经历。	
--	-----------------------------------	--

(3) 考核时量

考试时间：60 分钟

(4) 评分标准

模块总分	评价内容	配分	考核点	备注	
专业基本技能模块一：英语语言应用（总分100分，占总评分的30%）	职业素养与操作规范（10分）	2分	（1）具备外贸从业人员基本素质，认真严谨、耐心细致、恪守信誉、实事求是、服从安排，听从指挥、举止文明，记2分。	在考试过程中不服从安排、举止不当者，记0分。	
		2分	（2）具备外贸从业人员良好的翻译素养，认真严谨，耐心细致，记2分。	考试过程中出现与所述能力及素养不符，扣1-2分。	
		2分	（3）具备外贸从业人员良好的沟通能力、表达能力和合作意识，待人真诚礼貌，记2分。	考试过程中出现与所述能力及素养不符，扣1-2分。	
		2分	（1）具备使用办公设备和 Office 办公软件的能力，在考核过程中以及考核结束后，不私自更换电脑、不随意关闭或重启电脑，没征求监考老师同意不随意提前或推迟交卷，记2分。	若私自更换电脑、随意关闭或重启电脑，记0分。	
		2分	（2）能严格遵守企业 6S 管理要求（整理、整顿、清扫、清洁、素养、安全），记2分。	若未遵守企业 6S 管理要求，记0分。	
		10分	（1）阅读并理解所给外贸公司介绍资料，检索、筛选有效信息，记10分。		
	作品（90分）	国际商务信息检索（40分）	30分	（2）补充完善信息要点，每空不超过3个单词，每空3分，共10空，记30分。	大小写错误每处扣0.5分；答案不完整每处扣1分；拼写错误每处计0分
		商务文书翻译（50分）	15分	（1）能准确理解所给商务文书，语义信息理解正确，内容完整，记15分。	主要内容每缺失1处，扣2分
			15分	（2）能熟练运用商务翻译技巧、国际贸易和英语语言综合知识，语言表达通顺，符合商务文体特征，记15分。	专业术语、贸易惯例、法规、条款等翻译错误，每2处错误扣1分。
			10分	（3）语言表达通顺，语法、句型使用正	单词、语法每错3

			确，记 10 分。	处扣 1 分。
		10 分	(4) 译文表达准确，双语转换顺畅，体裁运用恰当，标点运用正确，记 10 分。	错别字、标点、句型表达，每 2 处错误扣 1 分。

12. 试题编号：1-1-12 国际商务信息检索与商务文书翻译

(1) 任务描述

任务 1：国际商务信息检索(40 分)

内容：关键词检索

要求：阅读并理解所给信息；检索并筛选有效信息；补充完善信息要点。

Section I 国际商务信息检索(40 分)

Directions: Read the following brief introduction to Reach Cooling Group from the official website of the company.

A Brief Introduction to Reach Cooling Group

Reach Cooling Group is a worldwide top air conditioning manufacturer and marketer. We produce, import, and distribute air conditioner equipment, mini split (小型分体机), multi split (多联机), ducted systems (管道系统), cooling and heating, all voltages 60Hz or 50 Hz.

We are strategically headquartered in Hialeah, FL, with distribution centers in the U.S., China, Europe, and Brazil. We provide a high filling rate and prompt delivery for each order.

Reach Cooling Group has a long history of quality and expertise in the air conditioning market. Since its establishment in 1995, our corporation has grown tremendously to become one of the world's most renowned suppliers of the widest variety of Air Conditioning, Heating, Ventilation (通风) and Refrigeration Equipment and their related parts and components.

As we celebrated our Fifteenth Anniversary in 2009, we are proud to have remained committed to developing advanced technology solutions in climate control for the masses of the world and look into the future with our extensive research activities for remaining as an unmatched industry leader.

We always pride ourselves on providing the best quality, highest efficiency, yet with top reliability and affordability in air conditioning solutions across the world markets. By developing a specific focus in these key areas, we have been able to remain at the forefront of our industry.

Our main brands are: Pioneer ®, Infiniti TM, Mariner ® and Schneider-Krupps ® . We also supply our products under hundreds of other well known brands for our worldwide OEM clients.

Our Product Range:

Our Product Range is known to be the most extensive available in the market today. With capacities ranging from 500 watts (or 2000 BTUs) for tiny customized cooling units for sophisticated electronics, to as high as several thousand kilowatts (or several million BTUs) for industrial heating-cooling equipment, such as VRF systems and chillers, etc. Our products and equipment are made to be suitable for an almost infinite variety of applications, from custom specific, to domestic, commercial and even large industrial applications.

In short, our clients can enjoy a product range from the most simplistic solutions, such as mini split ductless equipment, to the most sophisticated ones which can even be custom designed based on specific requirements.

Quality Assurance

As we believe, the most important aspect in the choice for equipment is quality and efficiency and we take pride in our products, having a very high reputation in both these areas. We have undertaken all necessary measures in every step of manufacturing and design processes for quality assurance, reliability and durability. Our factories follow strict ISO guidelines and other worldwide accepted standards. Every product is subjected to thorough testing in highly advanced laboratories in their development stages to assure they can handle the operational pressures of the world's harshest environmental conditions without a glitch. Additionally, no matter how small it is, one random sample from each batch is vigorously tested for every single batch of units manufactured as a precaution to avoid human errors and component specific defects.

Quality is always number one priority and our proud record proves that every day.

Our Family of Distributors

We are a big and proud family of a successful distribution network throughout

the world. Every one of our dealers and distributors are considered as an integral part of our family, well versed in their fields, providing the utmost service with high reliability and best pricing. Most of our product range is available from dealer stock or can be delivered quickly from strategically located distribution centers or factories.

Our distributor network employs highly trained engineering and service staff, and stocks all necessary spare parts in their inventories. Additionally, our headquarters office is always available to answer any technical questions and ship any needed spare part to anywhere in the world, should that becomes necessary.

Our Manufacturing Base

Since we started with manufacturing some of our equipment in the U.S.A. in the beginning years, we have expanded our manufacturing base into several other countries in Asia. Currently, our product range is produced in several professional factories located through the globe, depending on the product group. Our clientele have always been welcomed to visit our manufacturing bases for furthering their knowledge of our products and capabilities.

Research, Development and Innovation

In our field of business, we have been known to create the ideas which others usually follow. During our successful existence, we have been the leaders of development in many new technologies, ideas, products and marketing applications. Unlike some competitors, who prefer to copy others' products or services, we continually strive to bring new or highly enhanced products to the sophisticated world markets. Many others have attempted to copy our brands and products, yet failed one after another. Today, the world consumer is well educated to differentiate between a badly made copy and a top quality original.

Environmental Sensitivity and Responsibility

From the component selection to manufacturing processes and technologies, we always utilize methods and procedures to avoid any harm to our environment. We think and evaluate every process for its ecological parameters. The durability, serviceability and therefore the extended life expectancy of our products are known to be important factors in protecting the environmental waste. We also use sophisticated technologies in preventing leakages and component failures. All components are selected after going through rigorous testing for their environmental impact and hazardous substance content. Where applicable, our products comply with RoHS and other environmental regulations.

Task: Search for useful information in the passage and complete the summary below. Fill in each blank with NO MORE THAN THREE WORDS.

Reach Cooling Group Profile

Founded in 1._____, Reach Cooling Group is a manufacturer and marketer of 2._____. The company is based in 3._____. With the most 4._____ product range in the market, Reach Cooling Group's products and equipment are made to be suitable for an almost 5._____ variety of applications. The company's factories follow strict 6._____ and other worldwide accepted standards. It has a successful 7._____ network and several professional factories 8._____. The company continually strives to provide new or 9._____ products with methods and procedures that are 10._____ to the environment.

任务 2：商务文书翻译(50 分)

内容：商务文书翻译

要求：阅读并理解所给商务文书；译文表达专业、术语准确，符合商务文体特征；内容完整，逻辑严谨，衔接流畅。

Section II 商务文书翻译(50 分)

Directions: Translate the following instruction manual into Chinese.

Location of the Generator Room (发电机房)

Install it on the ground or on the roof.

If the installment is restricted, install the main engine and the pumps(泵组) in the basement. Install the cooling tower on the ground or on the roof.

If installed in the basement, don't choose metal generator room. The main engine and pumps should be in the same generator room to reduce the use of pipe(管道).

(2) 实施条件

项目	基本实施条件	备注
场地	每个商务英语实训室配置 40 个操作台面和座位,每个实训室照明通风良好。	必备
设备	每个商务英语实训室配有 1 台服务器、40—50 台计	必备

	算机，并安装 Office 办公软件，配置局域网。	
测评专家	每 40 名考生配备 1 名考评员。考评员要求具备至少二年以上从事国际贸易工作经验或三年以上商务英语实践教学指导经历。	必备

(3) 考核时量

考试时间：60 分钟

(4) 评分标准

模块总分	评价内容	配分	考核点	备注	
专业基本技能模块一：英语应用（总分 100 分，占总评分的 30%）	职业素养与操作规范（10 分）	2 分	(1) 具备外贸从业人员基本素质，认真严谨、耐心细致、恪守信誉、实事求是、服从安排，听从指挥、举止文明，记 2 分。	在考试过程中不服从安排、举止不当者，记 0 分。	
		2 分	(2) 具备外贸从业人员良好的翻译素养，认真严谨，耐心细致，记 2 分。	考试过程中出现与所述能力及素养不符，扣 1-2 分。	
		2 分	(3) 具备外贸从业人员良好的沟通能力、表达能力和合作意识，待人真诚礼貌，记 2 分。	考试过程中出现与所述能力及素养不符，扣 1-2 分。	
		2 分	(1) 具备使用办公设备和 Office 办公软件的能力，在考核过程中以及考核结束后，不私自更换电脑、不随意关闭或重启电脑，没征求监考老师同意不随意提前或推迟交卷，记 2 分。	若私自更换电脑、随意关闭或重启电脑，记 0 分。	
		2 分	(2) 能严格遵守企业 6S 管理要求（整理、整顿、清扫、清洁、素养、安全），记 2 分。	若未遵守企业 6S 管理要求，记 0 分。	
		10 分	(1) 阅读并理解所给外贸公司介绍资料，检索、筛选有效信息，记 10 分。		
	作品（90 分）	国际商务信息检索（40 分）	30 分	(2) 补充完善信息要点，每空不超过 3 个单词，每空 3 分，共 10 空，记 30 分。	大小写错误每处扣 0.5 分；答案不完整每处扣 1 分；拼写错误每处计 0 分
			15 分	(1) 能准确理解所给商务文书，语义信息理解正确，内容完整，记 15 分。	主要内容每缺失 1 处，扣 2 分
		商务文书翻译（50 分）	15 分	(2) 能熟练运用商务翻译技巧、国际贸易和英语语言综合知识，语言表达通顺，	专业术语、贸易惯例、法规、条款等

		分)		符合商务文体特征, 记 15 分。	翻译错误, 每 2 处错误扣 1 分。
			10 分	(3) 语言表达通顺, 语法、句型使用正确, 记 10 分。	单词、语法每错 3 处扣 1 分。
			10 分	(4) 译文表达准确, 双语转换顺畅, 体裁运用恰当, 标点运用正确, 记 10 分。	错别字、标点、句型表达, 每 2 处错误扣 1 分。

13. 试题编号: 1-1-13 国际商务信息检索与商务文书翻译

(1) 任务描述

任务 1: 国际商务信息检索(40 分)

内容: 关键词检索

要求: 阅读并理解所给信息; 检索并筛选有效信息; 补充完善信息要点。

Section I 国际商务信息检索(40 分)

Directions: Read the following brief introduction to Innovair Corporation from the official website of the company.

A Brief Introduction to Innovair Corporation

Established in Miami, Florida, Innovair Corporation specializes in the manufacture of efficient green technology for a wide range of residential and commercial Air-conditioning and Refrigeration products. Our success has been built on a strong reputation of superior quality, value, excellent service, honesty and integrity. Striving for excellence, it commits itself to continuing research and development in Air-conditioning and Refrigeration technology.

Aiming to be on the forefront of product development and innovative design, as well as the optimization of its unit's performance, Innovair Corporation designed and manufactured high quality equipments that are well-engineered, reliable, and cost-effective. Today, Innovair Corporation offers several complete lines of Air-conditioning and Refrigeration products not only meeting customer satisfaction, but even exceeding their expectations.

Our long list of available standard and optional features makes them the ideal

choice for residential and commercial projects. It is a great benefit in terms of quality, cost and efficiency. Innovair Corporation team efforts have been focused on providing value to our customers.

Our Philosophy

To maintain our aim to be in the forefront of the Air-conditioning & Refrigeration industry, we have built a team of professionals focused on quality and integrity who consistently exceed the expectations of our customers. Employees in Innovair Corporation give utmost importance to respecting individuality and diversity among each other.

Every employee in Innovair Corporation adheres to company policies and procedures at all times. We all pledge to be honest, ethical and to always do the right thing. When performing our duties, we always aim for customer satisfaction through clean, fast and quality workmanship. We are committed to encouraging and honing individual skills and talents in order to contribute to employees' career growth while better ensuring quality output from our manufactured products.

Our Values

Because the comfort and well being of your business, home and family is at stake, Innovair Corporation has gone to great lengths to establish and adhere to a number of core values that will ensure your satisfaction. With our commitment to excellence, we strive to provide the highest quality products to meet your every unique need. Our mission is to exceed customers' expectations in all aspects of Air-conditioning and Refrigeration requirements. We have set the highest standards of service for others to follow in our industry.

Our business operates with competency, integrity, and honesty in mind. Respect towards customers, suppliers, and work associates are strongly emphasized while promoting teamwork and collaboration. This enables us to develop strong lines of communication within the organization and with our customers, which in turn, leads to the trust and confidence that is essential to maintain long term relationships and happy customers.

The Experience

The engineers at Innovair Corporation have many years of experience in the design of Air-conditioning and Refrigeration products and similar applications.

Our sales and marketing department is an extension of our design team. Our remarkable customer service ensures all your questions are answered and that you are

satisfied with your every purchase. We are passionate about what we do and a good customer report is our reward.

Environment Friendly Refrigerants

Faced with today's tough environmental challenges and with global warming, we are more committed than ever to develop solutions which utilize sustainable energy sources in order to conserve our planet's non-renewable reserves of fossil fuels. We offer a wide range of eco-friendly heat pumps and refrigeration products constantly adding more to our list. Our CFX series uses R410A that is chlorine free and non-depleting refrigerant. Such will not only help save money on energy bills but also help reduce carbon dioxide emissions in the atmosphere to help control global warming.

The Solution

Our Air-conditioning and Refrigeration are part of a market-leading range of superior efficiency products from Innovair Corporation.

Air-conditioning units are available up to 5 tons and custom units up to 100 tons. Hermetic Refrigeration units are available from 3/4 HP to 5 HP and Semi-hermetic are available from 2 HP to 30 HP in LOW-MED-HIGH temp. There are units to meet your every need.

On top of that, Innovair Corporation is dedicated to providing the best possible solution for families and businesses in Florida, across United States and to outside regions. You can count on us to provide you with a system that fits your unique needs.

We can meet the expectations of the most demanding projects with our broad based knowledge of our industry. No matter what your Air-conditioning and Refrigeration requirements are, Innovair Corporation can deliver a solution.

Task: Search for useful information in the passage and complete the summary below. Fill in each blank with NO MORE THAN THREE WORDS.

Innovair Corporation Profile

Innovair Corporation is a manufacturer of 1. _____ and commercial 2. _____ products. Aiming to be on 3. _____ of the industry, the company has built a team of professionals who consistently 4. _____ the expectations of the customers. Faced with 5. _____ and with global warming, the company is committed to develop solutions which utilize 6. _____ and offer a wide range of 7. _____ products. Innovair Corporation employs 8. _____ engineers and offers 9. _____ customer services. It can meet the expectations of the most

10. _____ projects.

任务 2: 商务文书翻译(50 分)

内容: 商务文书翻译

要求: 阅读并理解所给商务文书; 译文表达专业、术语准确, 符合商务文体特征; 内容完整, 逻辑严谨, 衔接流畅。

Section II 商务文书翻译(50 分)

Directions: Translate the following advertisement into Chinese.

Innovair Air-Conditioner Starts Wonderful Life

Innovative technology, superior quality.

Fast cooling, low noise.

Scientific design, excellent appearance.

The forerunner(先驱) of the age of air conditioner, the leader of the age of air conditioner.

Taking Innovair Air-conditioner to home, you can enjoy coolness for a whole summer.

Taking Innovair Air-conditioner to home, you can enjoy comfort for good.

Innovair Air-conditioner, makes a better life.

With Innovair Air-conditioner, splendid life will be in your hands.

(2) 实施条件

项目	基本实施条件	备注
场地	每个商务英语实训室配置 40 个操作台面和座位, 每个实训室照明通风良好。	必备
设备	每个商务英语实训室配有 1 台服务器、40—50 台计算机, 并安装 Office 办公软件, 配置局域网。	必备
测评专家	每 40 名考生配备 1 名考评员。考评员要求具备至少二年以上从事国际贸易工作经验或三年以上商务英语实践教学指导经历。	必备

(3) 考核时量

考试时间：60 分钟

(4) 评分标准

模块总分		评价内容	配分	考核点	备注	
专业基本技能模块一：英语语言应用（总分100分，占总评分的30%）	职业素养与操作规范（10分）	职业素养（6分）	2分	(1) 具备外贸从业人员基本素质，认真严谨、耐心细致、恪守信誉、实事求是、服从安排，听从指挥、举止文明，记2分。	在考试过程中不服从安排、举止不当者，记0分。	
			2分	(2) 具备外贸从业人员良好的翻译素养，认真严谨，耐心细致，记2分。	考试过程中出现与上述能力及素养不符，扣1-2分。	
			2分	(3) 具备外贸从业人员良好的沟通能力、表达能力和合作意识，待人真诚礼貌，记2分。	考试过程中出现与上述能力及素养不符，扣1-2分。	
		操作规范（4分）	2分	(1) 具备使用办公设备和 Office 办公软件的能力，在考核过程中以及考核结束后，不私自更换电脑、不随意关闭或重启电脑，没征求监考老师同意不随意提前或推迟交卷，记2分。	若私自更换电脑、随意关闭或重启电脑，记0分。	
			2分	(2) 能严格遵守企业 6S 管理要求（整理、整顿、清扫、清洁、素养、安全），记2分。	若未遵守企业 6S 管理要求，记0分。	
		国际商务信息检索（40分）	10分	10分	(1) 阅读并理解所给外贸公司介绍资料，检索、筛选有效信息，记10分。	
	(2) 补充完善信息要点，每空不超过3个单词，每空3分，共10空，记30分。				大小写错误每处扣0.5分；答案不完整每处扣1分；拼写错误每处计0分	
	作品（90分）		商务文书翻译（50分）	15分	(1) 能准确理解所给商务文书，语义信息理解正确，内容完整，记15分。	主要内容每缺失1处，扣2分
				15分	(2) 能熟练运用商务翻译技巧、国际贸易和英语语言综合知识，语言表达通顺，符合商务文体特征，记15分。	专业术语、贸易惯例、法规、条款等翻译错误，每2处错误扣1分。
				10分	(3) 语言表达通顺，语法、句型使用正确，记10分。	单词、语法每错3处扣1分。
				10分	(4) 译文表达准确，双语转换顺畅，体裁运用恰当，标点运用正确，记10分。	错别字、标点、句型表达，每2处错误扣1分。

14. 试题编号: 1-1-14 国际商务信息检索与商务文书翻译

(1) 任务描述

任务 1: 国际商务信息检索(40 分)

内容: 关键词检索

要求: 阅读并理解所给信息; 检索并筛选有效信息; 补充完善信息要点。

Section I 国际商务信息检索(40 分)

Directions: Read the following brief introduction to GreenStar Energy Systems & Alliance from the official website of the company.

A Brief Introduction to GreenStar Energy Systems & Alliance

Millions of residential and commercial property owners across North America, as well as around the globe, rely on heating and cooling systems from GreenStar Energy Systems & Alliance. GreenStar has been designing, manufacturing and marketing these quality systems under several brand names for more than 50 years. Products are made in world-class manufacturing facilities located in the U.S., Mexico and Canada. We rely on one of the largest networks of independent wholesale distributors and contractors in North America to distribute our products.

GreenStar has been growing through the years by developing diversified brands and acquiring competitor brands. Its goal was to establish its presence in all available market niches. We take pride in our long history of service to the heating and air conditioning industry. And as the company has grown, we have kept focus on craftsmanship and embraced new technology to make our products more energy efficient, durable, reliable, and easier to install and maintain. We also offer technical training and support to ensure that dealers understand how to install and service our products. The FAST® Parts business ensures that parts and accessories that might be needed to service our products are readily available.

Because we were founded on a standard of excellence, our products are manufactured to some of the industry's toughest standards and are covered by some of the best warranties in the industry.

Rich in History

With decades of experience in the heating and cooling industry, GreenStar has a long tradition of excellence behind it. In fact, the company can trace its roots back to the early 1900s, when cast-iron stoves were the order of the day. Since then, markets have greatly changed, and technological advances have brought many new and innovative products. But through all the years and all the changes, one thing has always remained the same—our absolute dedication to quality. This dedication now spreads itself over a world-class organization. GreenStar is a company with huge assets in engineering manufacturing and service support; a company that not only has a rich past, but is also always evolving into the future.

Strength in Numbers

When it comes to manufacturing, GreenStar has several world-class facilities at its disposal. Our plants in Sanford, Florida; Tyler, Texas; Indianapolis, Indiana; and Monterrey, Mexico are capable of turning out more than a million heating and cooling units per year. And our 500,000-square-foot distribution center in Tampa, Florida is designed to expedite shipping and delivery, so your contractor has what you need when you need it.

Higher Standards

At GreenStar, we don't just say we're better—we prove it over and over again. Our entire manufacturing effort goes into making our products the high-quality systems your family deserves. From the minute we commit ourselves to a product, we test and retest components and assemblies in the lab, on the assembly line, and in selected homes all over the country. Nothing goes into our systems until we are satisfied it meets our high standards for quality and dependability.

Created For You

Whether you need an ultra efficiency gas furnace or air conditioner often depends on where you live. Whatever your needs may be, there's a GreenStar ® heating and cooling product to match them—from split system air conditioners and heat pumps to gas and oil furnaces, plus a variety of packaged products. No matter where you live, there's a high quality GreenStar product specifically engineered to suit your home.

Comfort Zone

Every GreenStar product is built to deliver quality, comfort, and efficiency. And we design in features that save your contractor valuable time when installing and servicing systems—time you won't have to pay for in labor costs. For further peace of

mind, all products are backed by a minimum five year parts limited warranty. Most of our products also have additional limited warranty protection on key components. And for extra peace of mind, there's HELP® (Homeowner's Extended Labor Program). HELP picks up where the factory parts warranty stops by ensuring that all repair costs are covered.

Quality Above All

Our decades of experience in the industry reinforce the dependability of every product we make. Perhaps that's why so many homeowners across the country have chosen GreenStar products to bring their families comfort and energy-saving efficiency all year round.

Task: Search for useful information in the passage and complete the summary below. Fill in each blank with NO MORE THAN THREE WORDS.

GreenStar Energy Systems & Alliance Profile

GreenStar is an American company that designs, manufactures and markets 1. _____ systems for use in 2. _____ property. The company can trace its roots back to 3. _____. It has been growing through the years by developing 4. _____ brands and acquiring 5. _____ brands. It has 6. _____ manufacturing facilities located in the U.S., 7. _____ and Canada. It also has a 500,000-square-foot 8. _____ in Tampa, Florida. Every GreenStar product is built to deliver quality, comfort, and 9. _____. Whatever the customers' needs may be, there's a GreenStar heating and cooling product to 10. _____ them.

任务 2: 商务文书翻译(50 分)

内容: 商务文书翻译

要求: 阅读并理解所给商务文书; 译文表达专业、术语准确, 符合商务文体特征; 内容完整, 逻辑严谨, 衔接流畅。

Section II 商务文书翻译(50 分)

Directions: Translate the following business correspondence into Chinese.

Dear sirs,

We are in receipt of your letter of July 18th. In reply(兹复), we regret to inform you that we cannot do the business on your price. The recent survey shows that the Kidney

Beans(芸豆) are not so popular in our market. So, we hope that you can reduce your previous quotation by 5%, and then we may consider placing a large order.

As the market is declining and information shows that prices will continue their downward tendency(价格将继续下行). We wish you to consider our price and give us an early reply.

Yours Faithfully,

Li Ming

General Manager

(2) 实施条件

项目	基本实施条件	备注
场地	每个商务英语实训室配置 40 个操作台面和座位,每个实训室照明通风良好。	必备
设备	每个商务英语实训室配有 1 台服务器、40—50 台计算机,并安装 Office 办公软件,配置局域网。	必备
测评专家	每 40 名考生配备 1 名考评员。考评员要求具备至少二年以上从事国际贸易工作经验或三年以上商务英语实践教学指导经历。	必备

(3) 考核时量

考试时间: 60 分钟

(4) 评分标准

模块总分		评价内容	配分	考核点	备注
专业基本技能模块一: 英语语言应用	职业素养与操作规范(10分)	职业素养(6分)	2分	(1) 具备外贸从业人员基本素质,认真严谨、耐心细致、恪守信誉、实事求是、服从安排,听从指挥、举止文明,记 2 分。	在考试过程中不服从安排、举止不当者,记 0 分。
			2分	(2) 具备外贸从业人员良好的翻译素养,认真严谨,耐心细致,记 2 分。	考试过程中出现与上述能力及素养不符,扣 1-2 分。
			2分	(3) 具备外贸从业人员良好的沟通能力、表达能力和合作意识,待人真诚礼貌,记	考试过程中出现与上述能力及素养不

(总分100分,占总评分的30%)	操作规范(4分)	2分	2分。	符,扣1-2分。	
		2分	(1)具备使用办公设备和Office办公软件的能力,在考核过程中以及考核结束后,不私自更换电脑、不随意关闭或重启电脑,没征求监考老师同意不随意提前或推迟交卷,记2分。	若私自更换电脑、随意关闭或重启电脑,记0分。	
	国际商务信息检索(40分)	10分	(1)阅读并理解所给外贸公司介绍资料,检索、筛选有效信息,记10分。		
		30分	(2)补充完善信息要点,每空不超过3个单词,每空3分,共10空,记30分。	大小写错误每处扣0.5分;答案不完整每处扣1分;拼写错误每处计0分	
	作品(90分)	商务文书翻译(50分)	15分	(1)能准确理解所给商务文书,语义信息理解正确,内容完整,记15分。	主要内容每缺失1处,扣2分
			15分	(2)能熟练运用商务翻译技巧、国际贸易和英语语言综合知识,语言表达通顺,符合商务文体特征,记15分。	专业术语、贸易惯例、法规、条款等翻译错误,每2处错误扣1分。
			10分	(3)语言表达通顺,语法、句型使用正确,记10分。	单词、语法每错3处扣1分。
			10分	(4)译文表达准确,双语转换顺畅,体裁运用恰当,标点运用正确,记10分。	错别字、标点、句型表达,每2处错误扣1分。

15. 试题编号: 1-1-15 国际商务信息检索与商务文书翻译

(1) 任务描述

任务1: 国际商务信息检索(40分)

内容: 关键词检索

要求: 阅读并理解所给信息; 检索并筛选有效信息; 补充完善信息要点。

Section I 国际商务信息检索(40分)

Directions: Read the following brief introduction to Clima Tech Corporation

from the official website of the company.

A Brief Introduction to Clima Tech Corporation

Clima Tech Corporation, located in Boise (博伊西), Idaho (爱达荷州), is an Employee Owned Corporation specializing in HVAC (Heating, Ventilating (通风), and Air Conditioning) Service and Maintenance. Our growth into one of the largest contractors in Boise is directly attributable to our attitude in providing the highest level of quality in all that we do. We have recently opened a branch office in Milwaukie (密尔沃基), Oregon (俄勒冈州), and are now able to offer the same professional service throughout eastern Oregon.

By incorporating a high standard of quality, innovation and decades of industry experience, Clima Tech Corporation has become a benchmark of excellence in the Pacific Northwest. We are proud to have been named twice to the list of INC Magazine's 5000 Fastest Growing Businesses in America for 2007 and again in 2010, as well as the Boise Metro Chamber of Commerce Business of the Year for 2004.

For commercial customers throughout Idaho, Oregon and SW Washington, our name has become synonymous with outstanding service and support through all phases of every project. Whether mechanical services or maintenance, the same level of expertise is guaranteed - every day, 24/7.

Company History

Clima-Tech was founded in 1972 by Mitchell Taback. The company began its long history as Climate Trane Air Conditioning Company, a part of the Trane Comfort Corp franchise network. Specializing in the installation and service of residential equipment, the company spent most of the 1970s filling a much needed void of professional, quality oriented contractors in the Boise market. It was this same dedication to providing excellent service and quality workmanship that propelled Climate Trane into the commercial marketplace.

In 1984, Climate Trane changed its name to Clima Tech Corporation as a result of the Trane Company's purchase of General Electric's central air conditioning department.

Clima Tech Corporation started as, and remains today, a full-service HVAC provider. We specialize in a complete range of products and services, including the design and installation of new equipment, comprehensive maintenance programs and 24/7 emergency service.

Today, the company has transitioned to the second generation. Brad Taback,

President and CEO, has positioned Clima-Tech to continue to move forward into the 21st Century as a leader in the markets we serve.

Our outstanding reputation in our markets comes from the dedication and commitment to excellence which is represented in all of our 100 plus employees.

Clima Tech Corporation Mission

Mission: Clima Tech Corporation's Mission is to completely satisfy every one of our customers by consistently providing real value in the development and delivery of innovative, high quality, responsive HVAC services and solutions to the markets we serve.

Vision: Clima Tech Corporation's Vision is to provide the best service experience our customers will ever have.

Values: Recognizing that Clima Tech Corporation would not exist without customers, employees, vendors, and community, our philosophy is to:

Simply provide the highest quality HVAC service imaginable to our customers.

Provide our employees the opportunity for personal and professional fulfillment, ensuring the enrichment of our organization, and the highest standard of living for their families.

Give our vendors fair and honest treatment so that we will receive the best value for our purchases, and realize savings that will be passed on to our customers.

Actively participate in organizations that work to improve the quality of our community, making it a better place to live and work.

Mechanical Services

When maintenance is neglected, energy costs rise significantly and the life of the equipment drops dramatically. According to the U.S. Department of Energy, it is estimated that HVAC systems are responsible for 40% to 60% of a buildings energy use. The secret to controlling these costs is an aggressive maintenance program designed to reduce costs for emergency services, equipment replacement, and to help you control your energy usage and focus on your energy performance.

Clima Tech Corporation offers full mechanical services to non-residential customers throughout southern Idaho and eastern Oregon. We have a knowledgeable and experienced staff of mechanical installation and service technicians with areas of expertise in all aspects of mechanical heating and cooling. Our service technicians are dispatched from our main office in Boise as well as our offices in Idaho Falls and Pocatello.

Read what our customers are saying about the great service and the overall commitment to owner satisfaction and occupant comfort they receive from the team at Clima Tech Corporation.

According to Building Owners and Managers Association - BOMA, there are three main reasons a tenant will select or remain in leased space: building comfort, cleanliness, relationship with property manager. We have the experience and dedication to help you maintain your facilities to maximize your occupancy rate.

Task: Search for useful information in the passage and complete the summary below. Fill in each blank with NO MORE THAN THREE WORDS.

Clima Tech Corporation Profile

Founded in 1. _____, Clima Tech Corporation is a 2. _____ company specializing in HVAC in Boise. Originally named 3. _____ Air Conditioning Company, the company changed its name to Clima Tech Corporation after 4. _____ General Electric's central air conditioning department in 5. _____. Today the company has 6. _____ employees. It has a 7. _____ newly opened in Oregon and offers full mechanical services to 8. _____ throughout southern Idaho and eastern Oregon. Clima Tech Corporation has been listed among America's 5000 9. _____ for 2007 and 2010. The company's 10. _____ is to provide the best service experience its customers will ever have.

任务 2：商务文书翻译（50 分）

内容：商务文书翻译

要求：阅读并理解所给商务文书；译文表达专业、术语准确，符合商务文体特征；内容完整，逻辑严谨，衔接流畅。

Section II 商务文书翻译(50 分)

Directions: Translate the following product description into Chinese.

Equipped with a dual(两档) air flow system and fresh air device(装置), this air conditioner ensures comfortable temperatures in all seasons. Supplying fresh air with a ventilator(通风装置), the air conditioner can filter(过滤) dust and absorbs humidity(湿气). It creates an ideal environment for living and working. Besides, with compactor(压缩机) designed and made in China, the air conditioner is compact (紧凑的) in structure, elegant in design, efficient, low in sound and easy to operate.

(2) 实施条件

项目	基本实施条件	备注
场地	每个商务英语实训室配置 40 个操作台面和座位,每个实训室照明通风良好。	必备
设备	每个商务英语实训室配有 1 台服务器、40—50 台计算机,并安装 Office 办公软件,配置局域网。	必备
测评专家	每 40 名考生配备 1 名考评员。考评员要求具备至少二年以上从事国际贸易工作经验或三年以上商务英语实践教学指导经历。	必备

(3) 考核时量

考试时间: 60 分钟

(4) 评分标准

模块总分		评价内容	配分	考核点	备注
专业基本技能模块一: 英语语言应用 (总分 100 分, 占总评分的 30%)	职业素养与操作规范 (10 分)	职业素养 (6 分)	2 分	(1) 具备外贸从业人员基本素质, 认真严谨、耐心细致、恪守信誉、实事求是、服从安排, 听从指挥、举止文明, 记 2 分。	在考试过程中不服从安排、举止不当者, 记 0 分。
			2 分	(2) 具备外贸从业人员良好的翻译素养, 认真严谨, 耐心细致, 记 2 分。	考试过程中出现与所述能力及素养不符, 扣 1-2 分。
			2 分	(3) 具备外贸从业人员良好的沟通能力、表达能力和合作意识, 待人真诚礼貌, 记 2 分。	考试过程中出现与所述能力及素养不符, 扣 1-2 分。
	操作规范 (4 分)		2 分	(1) 具备使用办公设备和 Office 办公软件的能力, 在考核过程中以及考核结束后, 不私自更换电脑、不随意关闭或重启电脑, 没征求监考老师同意不随意提前或推迟交卷, 记 2 分。	若私自更换电脑、随意关闭或重启电脑, 记 0 分。
			2 分	(2) 能严格遵守企业 6S 管理要求 (整理、整顿、清扫、清洁、素养、安全), 记 2 分。	若未遵守企业 6S 管理要求, 记 0 分。
	作品 (90 分)	国际商务信息检索	10 分	(1) 阅读并理解所给外贸公司介绍资料, 检索、筛选有效信息, 记 10 分。	
30 分			(2) 补充完善信息要点, 每空不超过 3 个单词, 每空 3 分, 共 10 空, 记 30 分。	大小写错误每处扣 0.5 分; 答案不完	

	(40分)			整每处扣1分；拼写错误每处计0分
	商务文书翻译 (50分)	15分	(1) 能准确理解所给商务文书，语义信息理解正确，内容完整，记15分。	主要内容每缺失1处，扣2分
		15分	(2) 能熟练运用商务翻译技巧、国际贸易和英语语言综合知识，语言表达通顺，符合商务文体特征，记15分。	专业术语、贸易惯例、法规、条款等翻译错误，每2处错误扣1分。
		10分	(3) 语言表达通顺，语法、句型使用正确，记10分。	单词、语法每错3处扣1分。
		10分	(4) 译文表达准确，双语转换顺畅，体裁运用恰当，标点运用正确，记10分。	错别字、标点、句型表达，每2处错误扣1分。

16. 试题编号：1-1-16 国际商务信息检索与商务文书翻译

(1) 任务描述

任务1：国际商务信息检索(40分)

内容：关键词检索

要求：阅读并理解所给信息；检索并筛选有效信息；补充完善信息要点。

Section I 国际商务信息检索(40分)

Directions: Read the following brief introduction to Galaxy Refrigeration Private Limited Co. from the official website of the company.

A Brief Introduction to Galaxy Refrigeration Private Limited Co.

Established in the year 2003, we, Galaxy Refrigeration Private Limited Co. are engaged in the sphere of importing and supplying a wide range of white Westinghouse chillers, white Westinghouse dishwasher, white Westinghouse dryers and white Westinghouse microwaves. These are procured from one of the most reliable home appliances company, White Westinghouse of USA. Apart from this company, we are also associated with various other original manufacturers such as Sony, Compaq, Yamaha, JVC, Sanyo, IBM, HP, Canon, Samsung, Nokia, Bosch, and Olympus, from where we procure these products and supply to our clients spread all

over the world.

The entire range is manufactured at advanced laboratories that are equipped with latest equipment ensuring optimum performance of the refrigerators, ventilation systems, commercial ventilation systems, chilling units, commercial chilling units and others units. Already checked at manufacturers end, we also check the quality of these White Westinghouse Refrigerators, White Westinghouse Freezer, White Westinghouse Microwave, White Westinghouse Air Care and White Westinghouse Washer & Dryer at our end and provide defect free products to our clients.

Being a client centric organization, we ensure trouble free functioning of these products and hence, we provide prompt after sale service to them. Under the able guidance of our owner, Mr. Naresh Kapoor and Mr. Chandar Kumar, who have been in this business for 20 years, we have touched new heights of success in the industry.

Our Associate

We take pride in being associated with White Westinghouse that is one of the leading home appliances companies of USA. The company was formed by the acquisition of the Westinghouse Electric Corporation's Appliance Unit by white consolidated industries in 1975. Later on the company entered into the Appliance Industry and acquired COPEMAN Electric Stove Company in 1977.

It started manufacturing electric products that included automatic washing machines, frost-free refrigeration and other that have been appreciated all over the world by global clients for low power consumption and low maintenance. These products are engineered with superior technology by using quality raw material and components that ensure durable performance & high functionality. We are a prominent importer of various electronic items from different companies such as:

Sony

Compaq

Yamaha

JVC

Sanyo

IBM

HP

Canon

Samsung

Nokia

Bosch

Olympus

White Westinghouse

Quality Assurance

We are a quality conscious organization and ensure that our electric appliances such as ventilation systems, commercial ventilation systems, chilling units, commercial chilling units, automatic washing machines, stainless steel refrigerators, commercial washing machines, etc, are up to the mark and provide great level of satisfaction to our clients. Even being a supplier, we ensure that the entire range of products, we procure from renowned vendors and manufacturers are tested on various quality parameters so that our clients face no trouble in using these products.

With an aim towards offering maximum client satisfaction, we test our Refrigerators, Chilling Units & Ventilation and Washer & Dryer rigidly and follow stringent quality measures. We test our cooling and refrigeration solutions on the following parameters:

Noise level

Temperature and corrosion resistance

Functionality

Robust construction

Warehousing

In our unit we have a large warehousing facility to store our Refrigerators, Chilling Units & Ventilation and Washer & Dryer. The unit is managed by expert and efficient warehousing professionals, who manage proper inventory and helps us in storing the above mentioned range systematically. The warehouse is segregated into various sections, so that we can store the products separately ensuring fast retrieval of the same, when needed. Further, the products are stored after proper labeling and packaging. We use high quality of packaging material to protect our products from dust, water and heat. Our warehousing professionals maintain a proper inventory to ensure systematic arrangements of every consignment.

Wide Distribution Network

Over the period of time, we have developed a wide distribution network all over the country that has helped us in creating large clientele. Our distributors have rich industrial experience and market knowledge that assist us in serving our clients in best possible manner.

They understand the market dynamics that enable us to procure desired products from our associates and fulfill the requirements of the clients within committed time frame. Further, due to our expert procurement agents, we have been able to source reliable ventilation systems, commercial ventilation systems, chilling units, commercial chilling units, automatic washing machines, stainless steel refrigerators, commercial washing machines, refrigerators, chilling units & ventilation and washer & dryer for our valued clients. Further, we have also tied up with various C&F Agents, who assists us in ensuring quick delivery.

Task: Search for useful information in the passage and complete the summary below. Fill in each blank with NO MORE THAN THREE WORDS.

Galaxy Refrigeration Private Limited Co. Profile

Founded in 1. _____, Galaxy Refrigeration Private Limited Co. specializes in 2. _____ of White Westinghouse Appliances, which are 3. _____ from one of the most reliable 4. _____ company, White Westinghouse of USA. The company also procures from various other 5. _____ and supplies to the clients spread all over the world. With an aim towards offering 6. _____, the company tests the products rigidly and follows stringent 7. _____. The company has a 8. _____ to store the products. It has developed a wide 9. _____ network all over the country that helps to 10. _____.

任务 2: 商务文书翻译 (50 分)

内容: 商务文书翻译

要求: 阅读并理解所给商务文书; 译文表达专业、术语准确, 符合商务文体特征; 内容完整, 逻辑严谨, 衔接流畅。

Section II 商务文书翻译(50 分)

Directions: Translate the following instruction manual into Chinese.

Your cellphone is a product of superior design and craftsmanship(工艺) and should be treated with care. To obtain the best performance, please read the following instructions carefully.

- Keep the cellphone dry.
- Do not use or store the cellphone in dusty, dirty areas.
- Do not attempt to open the cellphone other than as instructed in this guide.

·Do not drop, knock, or shake the device.

·Use chargers indoors.

(2) 实施条件

项目	基本实施条件	备注
场地	每个商务英语实训室配置 40 个操作台面和座位,每个实训室照明通风良好。	必备
设备	每个商务英语实训室配有 1 台服务器、40—50 台计算机,并安装 Office 办公软件,配置局域网。	必备
测评专家	每 40 名考生配备 1 名考评员。考评员要求具备至少二年以上从事国际贸易工作经验或三年以上商务英语实践教学指导经历。	必备

(3) 考核时量

考试时间: 60 分钟

(4) 评分标准

模块总分	评价内容	配分	考核点	备注
专业基本技能模块一: 英语语言应用 (总分 100 分, 占总评分的 30%)	职业素养与操作规范 (10 分)	2 分	(1) 具备外贸从业人员基本素质, 认真严谨、耐心细致、恪守信誉、实事求是、服从安排, 听从指挥、举止文明, 记 2 分。	在考试过程中不服从安排、举止不当者, 记 0 分。
		2 分	(2) 具备外贸从业人员良好的翻译素养, 认真严谨, 耐心细致, 记 2 分。	考试过程中出现与所述能力及素养不符, 扣 1-2 分。
		2 分	(3) 具备外贸从业人员良好的沟通能力、表达能力和合作意识, 待人真诚礼貌, 记 2 分。	考试过程中出现与所述能力及素养不符, 扣 1-2 分。
	操作规范 (4 分)	2 分	(1) 具备使用办公设备和 Office 办公软件的能力, 在考核过程中以及考核结束后, 不私自更换电脑、不随意关闭或重启电脑, 没征求监考老师同意不随意提前或推迟交卷, 记 2 分。	若私自更换电脑、随意关闭或重启电脑, 记 0 分。
		2 分	(2) 能严格遵守企业 6S 管理要求 (整理、整顿、清扫、清洁、素养、安全), 记 2 分。	若未遵守企业 6S 管理要求, 记 0 分。
作品	国际	10 分	(1) 阅读并理解所给外贸公司介绍资料,	

(90分)	商务信息检索(40分)		检索、筛选有效信息,记10分。	
		30分	(2) 补充完善信息要点,每空不超过3个单词,每空3分,共10空,记30分。	大小写错误每处扣0.5分;答案不完整每处扣1分;拼写错误每处计0分
	商务文书翻译(50分)	15分	(1) 能准确理解所给商务文书,语义信息理解正确,内容完整,记15分。	主要内容每缺失1处,扣2分
		15分	(2) 能熟练运用商务翻译技巧、国际贸易和英语语言综合知识,语言表达通顺,符合商务文体特征,记15分。	专业术语、贸易惯例、法规、条款等翻译错误,每2处错误扣1分。
		10分	(3) 语言表达通顺,语法、句型使用正确,记10分。	单词、语法每错3处扣1分。
		10分	(4) 译文表达准确,双语转换顺畅,体裁运用恰当,标点运用正确,记10分。	错别字、标点、句型表达,每2处错误扣1分。

17. 试题编号: 1-1-17 国际商务信息检索与商务文书翻译

(1) 任务描述

任务 1: 国际商务信息检索(40分)

内容: 关键词检索

要求: 阅读并理解所给信息; 检索并筛选有效信息; 补充完善信息要点。

Section I 国际商务信息检索(40分)

Directions: Read the following brief introduction to Devidayal (Sales) Limited from the official website of the company.

A Brief Introduction to Devidayal (Sales) Limited

The company Devidayal (Sales) Limited established in 1949 is part of a reputed and respected business house in India marketing its products under the brand name Devidayal Agrochemicals(农用化学品). Starting with the business of mining various ores and exporting to Japan, to export of BHC for locust (蝗虫) control to Russia in the 60's, today the company is an Emerging Leader in the business of Agrochemicals

/ Pesticides(杀虫剂) in India. In 2000, Devidayal (Sales) Ltd. was granted ISO 9002 certification and in 2004, the company updated it to ISO 9001. In 2005, DSL was deemed a one “STAR” Export House. The company believes in Total Quality Management. Having its registered office at Mumbai, the company has a modern manufacturing plant at Kalol (卡罗尔) (Dist. Panchmahal-Gujarat, Western India) backed by a strong R&D and excellent Quality Control Systems. The domestic market is catered to from its 15 Branch offices and 25 Stock Points spread all over the country. Besides having a substantial domestic market share, the company exports its products to around 35 countries covering Europe, South America, the Far East, Asia Pacific, Africa and the Middle East. 25% of its turnover is attributed to Exports. The Company has registered over 75 of their products overseas. The Company offers both technical grade pesticides as well as formulations (配方). Its formulations include Emulsifiable Concentrates (EC), Suspension Concentrates (SC), Wettable Powders (WP), Granules (GR) and Dusting Powders (DP) of Insecticides, Fungicides(杀菌剂) and Herbicides(除草剂).

Strength

56 years experience in serving farmers.

More than 150 products registered in India.

Strong domestic market presence with more than 6,000 dealers.

Wide product range, attractive packing, timely supplies and competitive pricing.

Policy of long term relationship with its customers, suppliers & employees.

Good business ethics and a satisfied customer base.

Quality products as per BIS/FAO/ International standards.

Stool Export house - Star Export house.

Manufacturing Facilities

The company has a modern plant at Kalol and is spread over an area of 200,000 sq.ft.and employs more than 400 employees. Its laboratory is well equipped with sophisticated instruments and maintains stringent quality control measures.

Customer service

The company provides Dossiers for product registrations overseas. Excellent support is provided for product promotion. With its strong R&D facilities, it is capable of meeting customers’ requirements on product specifications. It can supply products packed with Clients labels or in Neutral packing with switch B/L facility.

Products

Insecticides

Insects like caterpillars(毛虫) and aphids(蚜虫) can significantly reduce crop yields and quality. Insecticides help minimize this damage by controlling insect pests. The largest insecticide markets are in fruit and vegetables, cotton, rice and corn.

In addition to their use in agriculture, insecticides play an important role in public health programs to control diseases such as malaria(疟疾). It also helps to protect children and families from insects and pests such as cockroaches, fire ants, wasps, mosquitoes, rats and mice.

Fungicides

Fungicides prevent and cure diseases which can have severe adverse effects on crop yields and quality. The main markets are fruit and vegetables, cereals and rice.

Plant diseases are caused by a great variety of pathogens(病菌). Accordingly, this requires many products used singularly or in combination to control the full range of diseases in ways that minimize the chance of resistance building up.

Herbicides

Weeds are undesirable plants growing within a crop and they compete for resources such as nutrients, water and light. Without weed control, crop yields can be significantly reduced. Weeds can also cause further problems by harboring pests and diseases, interfering with harvest operations, and increasing costs of cleaning and drying the crop produce.

Selective herbicides have been derived from a wide range of different chemical classes with varying modes of action that have enabled the yield improvement in key crops such as corn, rice, soybeans and wheat.

Non-Selective herbicides eliminate all plants (if absorbed by green tissue) and are used primarily in plantation crops such as rubber, oil palm, orchards and vines. They are applied on weeds growing between the trees to facilitate passage in tropical crops, save moisture in vines and orchards, and to reduce erosion.

Task: Search for useful information in the passage and complete the summary below. Fill in each blank with NO MORE THAN THREE WORDS.

Devidayal (Sales) Limited Profile

Devidayal Sales Limited, founded in 1. _____, is a leading manufacturer Marketer of 2. _____ and pesticides in India. It began exporting BHC to 3. _____ in the 1960's. Its registered office is located in 4. _____, India and our 5. _____ is at Kalol. The company export products to about 6. _____

countries and have registered more than 7. _____ of its products overseas. The DSL Products range comprises: Insecticides for control of 8. _____ which reduce crop yields and quality, Fungicides against 9. _____ which can have severe adverse effects on crop yields and quality, and Herbicides for control of 10. _____ affecting crops.

任务 2：商务文书翻译（50 分）

内容：商务文书翻译

要求：阅读并理解所给商务文书；译文表达专业、术语准确，符合商务文体特征；内容完整，逻辑严谨，衔接流畅。

Section II 商务文书翻译(50 分)

Directions: Translate the following advertisement into Chinese.

Job Wanted

Marketing Assistant

Responsibility:

Responsible for the local management of marketing and sales activities according to the instruction from the head office.

Collect related information to the head office.

Provide assistance to the marketing manager for routine(日常的) work

Responsible for file management and client receiving

Requirements:

College diploma(大专文凭) and above

Good English and computer skills

Related working experience in the international organization

Patient, careful, supportive.

Has strong team work spirit.

If you have interest, please send your resume via e-mail.

(2) 实施条件

项目	基本实施条件	备注
场地	每个商务英语实训室配置 40 个操作台面和座位,每	必备

	个实训室照明通风良好。	
设备	每个商务英语实训室配有 1 台服务器、40—50 台计算机，并安装 Office 办公软件，配置局域网。	必备
测评专家	每 40 名考生配备 1 名考评员。考评员要求具备至少二年以上从事国际贸易工作经验或三年以上商务英语实践教学指导经历。	必备

(3) 考核时量

考试时间：60 分钟

(4) 评分标准

模块总分	评价内容	配分	考核点	备注	
专业基本技能模块一：英语语言应用（总分 100 分，占总评分的 30%）	职业素养与操作规范（10 分）	2 分	(1) 具备外贸从业人员基本素质，认真严谨、耐心细致、恪守信誉、实事求是、服从安排，听从指挥、举止文明，记 2 分。	在考试过程中不服从安排、举止不当者，记 0 分。	
		2 分	(2) 具备外贸从业人员良好的翻译素养，认真严谨，耐心细致，记 2 分。	考试过程中出现与上述能力及素养不符，扣 1-2 分。	
		2 分	(3) 具备外贸从业人员良好的沟通能力、表达能力和合作意识，待人真诚礼貌，记 2 分。	考试过程中出现与上述能力及素养不符，扣 1-2 分。	
	操作规范（4 分）	2 分	(1) 具备使用办公设备和 Office 办公软件的能力，在考核过程中以及考核结束后，不私自更换电脑、不随意关闭或重启电脑，没征求监考老师同意不随意提前或推迟交卷，记 2 分。	若私自更换电脑、随意关闭或重启电脑，记 0 分。	
		2 分	(2) 能严格遵守企业 6S 管理要求（整理、整顿、清扫、清洁、素养、安全），记 2 分。	若未遵守企业 6S 管理要求，记 0 分。	
	作品（90 分）	国际商务信息检索（40 分）	10 分	(1) 阅读并理解所给外贸公司介绍资料，检索、筛选有效信息，记 10 分。	
			30 分	(2) 补充完善信息要点，每空不超过 3 个单词，每空 3 分，共 10 空，记 30 分。	大小写错误每处扣 0.5 分；答案不完整每处扣 1 分；拼写错误每处计 0 分
		商务文书	15 分	(1) 能准确理解所给商务文书，语义信息理解正确，内容完整，记 15 分。	主要内容每缺失 1 处，扣 2 分

	翻译 (50分)	15分	(2) 能熟练运用商务翻译技巧、国际贸易和英语语言综合知识, 语言表达通顺, 符合商务文体特征, 记15分。	专业术语、贸易惯例、法规、条款等翻译错误, 每2处错误扣1分。
		10分	(3) 语言表达通顺, 语法、句型使用正确, 记10分。	单词、语法每错3处扣1分。
		10分	(4) 译文表达准确, 双语转换顺畅, 体裁运用恰当, 标点运用正确, 记10分。	错别字、标点、句型表达, 每2处错误扣1分。

18. 试题编号: 1-1-18 国际商务信息检索与商务文书翻译

(1) 任务描述

任务 1: 国际商务信息检索(40分)

内容: 关键词检索

要求: 阅读并理解所给信息; 检索并筛选有效信息; 补充完善信息要点。

Section I 国际商务信息检索(40分)

Directions: Read the following brief introduction to MainPlus Chemicals Ltd. (U.K.) from the official website of the company.

A Brief Introduction to MainPlus Chemicals Ltd.

MainPlus Chemicals Ltd. is a privately owned, U.K.-based company with over 30 years' experience in the manufacture, formulation (配方), packaging and exporting of agricultural, environmental health, industrial and veterinary (兽医的) products. We supply our products to over 90 countries worldwide and enjoy a reputation for supplying competitively-priced products of superior quality to agricultural, veterinary hygiene (保健) and environmental health industries.

Mainplus has a wealth of industry knowledge and experience throughout its various departments. A close working environment and excellent department interaction helps to ensure a seamless, effective working process which ultimately leads to satisfied stakeholders. Mainplus has both French and Spanish speaking staff and welcomes any enquires in either language.

Mainplus's history: the story so far.

First created in 1979, as then named, Mostyn Chemicals Company, the company began trading from a spare bedroom with three members of staff. The company grew from strength to strength, scooping the Queen's Award for Export and the Export Award for Small Businesses along the way.

In 1991, the company took a new direction as MainPlus Chemicals Ltd., and since 1991, our business has strengthened and expanded to serve over 90 countries worldwide.

2009 has brought Mainplus to new heights, from our rebrand to winning Excellence in International Trade award. We celebrated our 30th anniversary this July and are continuously striving to make a world of difference in agriculture, public health and veterinary care in more and more countries worldwide.

Our Mission

Our products safeguard the health of crops, people and animals everywhere. Our mission has traditionally been to produce quality products, and as we have grown over the years, so has our mission, to provide protection and reliability on a worldwide scale.

Today, we are striving to grow our business in a sustainable way, making a world of difference to agriculture, animal health, public health and industry in more and more countries worldwide.

Our Values

To provide high quality products and excellent service to all of our stakeholders. In addition to our factory's ISO 9001 quality assurance, the manufacture of many of our products in the United Kingdom ensures that our products are produced to an exceptionally high standard.

To provide protection and reliability on a worldwide scale by supplying high quality products through a network of local agents and distributors in countries all over the world.

To ensure that our bespoke product range meets individual customers' packaging, labeling, concentration, formulation and ease of use requirements. Multiple manufacturing locations enable us to provide greater flexibility on price, availability and order times so that we can process your order as efficiently as possible.

To ensure that large stocks of active ingredients and packaging materials are held at production facilities to enable quick order response timing.

To utilize our vast industry experience, product knowledge and language

capabilities to help our partners all over the world. Our in-house registrations department also has extensive experience in gaining product approvals for sale; creating product files for many products.

To maintain a high standard with an excellent, efficient and reliable service, available in English, French or Spanish.

Our products

Mainplus supplies a wide range of chemical products for use in Agriculture, Public Health and Veterinary Hygiene, specializing in the supply of insecticides (杀虫剂) for all applications worldwide. Searching the world for the best raw materials, we ensure that our products are of superior quality and competitively-priced. We manufacture our products to meet each and every customer's individual requirements, offering technical pesticides (杀虫剂), concentrates for local dilution and ready-formulated and packed products, including product labels prepared to client specifications.

Crop Protection

Agriculture forms the core of our business, and we work with each and every client to understand and supply the products they need because we know that no country is the same. We make all of our products to meet your country's agricultural needs. We specialize in bespoke manufacture, formulation and packaging of a range of pesticides for use on a wide variety of crops, in over 90 different countries all over the world.

Public Health

We specialize in bespoke pesticides for public health purposes, supplying many governments, NGOs and anti-malaria programmes with products that they need.

Veterinary care

The protection of livestock from insect pests such as ticks, lice, mites, fleas, and nuisance flies is an essential factor in the promotion and maintenance of good animal health. We can offer a range of insecticides supplied as formulated products, for direct application to animals, or for treatment of their housing.

Task: Search for useful information in the passage and complete the summary below. Fill in each blank with NO MORE THAN THREE WORDS.

MainPlus Chemicals Ltd. Profile

MainPlus Chemicals Ltd. was established in 1._____. Based in 2._____, the company specializes in manufacturing and exporting agricultural,

environmental health, veterinary and 3. _____ products used in over 4. _____ countries worldwide. The company's mission is to provide 5. _____ worldwide. The company's factory is ISO 9001 quality 6. _____. In 2009, the company won Excellence in 7. _____ award. MainPlus specializes in the supply of 8. _____ for all applications worldwide. It supplies a range of pesticides for use on a wide variety of 9. _____ and for 10. _____ purposes.

任务 2: 商务文书翻译 (50 分)

内容: 商务文书翻译

要求: 阅读并理解所给商务文书; 译文表达专业、术语准确, 符合商务文体特征; 内容完整, 逻辑严谨, 衔接流畅。

Section II 商务文书翻译(50 分)

Directions: Translate the following correspondence into Chinese.

With reference to your letter of August 18th, we are glad to know that the cargo(货物) was delivered promptly.

We regret, however, that case No. 24 did not contain the goods you ordered. We have made investigation on the matter and found that we did make a mistake in loading.

We have arranged for the correct goods to be dispatched(寄送) to you at once. The relevant documents will be mailed to you once they are ready.

We apologize for causing you a good deal of inconvenience.

(2) 实施条件

项目	基本实施条件	备注
场地	每个商务英语实训室配置 40 个操作台面和座位, 每个实训室照明通风良好。	必备
设备	每个商务英语实训室配有 1 台服务器、40—50 台计算机, 并安装 Office 办公软件, 配置局域网。	必备
测评专家	每 40 名考生配备 1 名考评员。考评员要求具备至少二年以上从事国际贸易工作经验或三年以上商务英语实践教学指导经历。	必备

(3) 考核时量

考试时间：60 分钟

(4) 评分标准

模块总分		评价内容	配分	考核点	备注
专业基本技能模块一：英语语言应用（总分100分，占总评分的30%）	职业素养与操作规范（10分）	职业素养（6分）	2分	(1) 具备外贸从业人员基本素质，认真严谨、耐心细致、恪守信誉、实事求是、服从安排，听从指挥、举止文明，记2分。	在考试过程中不服从安排、举止不当者，记0分。
			2分	(2) 具备外贸从业人员良好的翻译素养，认真严谨，耐心细致，记2分。	考试过程中出现与上述能力及素养不符，扣1-2分。
			2分	(3) 具备外贸从业人员良好的沟通能力、表达能力和合作意识，待人真诚礼貌，记2分。	考试过程中出现与上述能力及素养不符，扣1-2分。
		操作规范（4分）	2分	(1) 具备使用办公设备和 Office 办公软件的能力，在考核过程中以及考核结束后，不私自更换电脑、不随意关闭或重启电脑，没征求监考老师同意不随意提前或推迟交卷，记2分。	若私自更换电脑、随意关闭或重启电脑，记0分。
			2分	(2) 能严格遵守企业 6S 管理要求（整理、整顿、清扫、清洁、素养、安全），记2分。	若未遵守企业 6S 管理要求，记0分。
		作品（90分）	国际商务信息检索（40分）	10分	(1) 阅读并理解所给外贸公司介绍资料，检索、筛选有效信息，记10分。
	30分			(2) 补充完善信息要点，每空不超过3个单词，每空3分，共10空，记30分。	大小写错误每处扣0.5分；答案不完整每处扣1分；拼写错误每处计0分
	商务文书翻译（50分）		15分	(1) 能准确理解所给商务文书，语义信息理解正确，内容完整，记15分。	主要内容每缺失1处，扣2分
			15分	(2) 能熟练运用商务翻译技巧、国际贸易和英语语言综合知识，语言表达通顺，符合商务文体特征，记15分。	专业术语、贸易惯例、法规、条款等翻译错误，每2处错误扣1分。
			10分	(3) 语言表达通顺，语法、句型使用正确，记10分。	单词、语法每错3处扣1分。
			10分	(4) 译文表达准确，双语转换顺畅，体裁运用恰当，标点运用正确，记10分。	错别字、标点、句型表达，每2处错误扣1分。

19. 试题编号: 1-1-19 国际商务信息检索与商务文书翻译

(1) 任务描述

任务 1: 国际商务信息检索(40 分)

内容: 关键词检索

要求: 阅读并理解所给信息; 检索并筛选有效信息; 补充完善信息要点。

Section I 国际商务信息检索(40 分)

Directions: Read the following brief introduction to MH&W International Corp. from the official website of the company.

A Brief Introduction to MH&W International Corp.

MH&W International Corp. is a highly specialized sales and engineering organization in the United States, Canada and Mexico. Founded in 1968, MH&W has evolved into a technologically advanced company with two separate yet integrated operating divisions: Production Machining and Railroad Products. Within these divisions, MH&W can handle all your manufacturing needs. From design and prototyping, to high volume manufacturing and back to service parts, MH&W can and will meet your company's tooling and machining requirements and surpass your expectations.

We know having the state-of-the art technology alone is not enough. MH&W prides itself on delivering a quality product that meets your high standards every time. Our ISO Certified Quality Assurance system ensures that your job is inspected every step of the way.

With sales offices and warehouses in key cities throughout North America, MH&W is ready to serve its customers quickly and efficiently. In addition to providing high-quality reliable products, MH&W operates as an exclusive engineering and marketing interface between several major global manufacturers and its U.S., Canadian and Mexican customers.

Equipments

MH&W has made major investments to keep our production facilities on the cutting edge. Our latest additions, four Mazak machine centers with pallettechs, are

state of the art machines. They give MH&W a competitive advantage because of the large size range of parts they can machine. Our production facility handles average lot sizes from 50 to 500 units. Annual volumes range from 1,000 units to more than 40,000 units.

MH&W has 50 modern machining centers, many equipped with pallettechs, 4-Axis or Live Tooling that help reduce or eliminate setup time and speed processing time.

In addition, we have a wide array of grinding and hobbing equipment. It's all supported by the latest in quality assurance hardware, and computer systems such as AutoCAD, AutoCAD Inventor, SMART CAM, SolidWorks and Virtual Gibbs CAM Systems.

Quality

As an industry leader, MH&W has a responsibility to uphold our commitment to quality assurance. Our Production, Short Run and Railroad Divisions are all certified to ISO 9001:2008 and MH&W places high value on ethical business practices, emphasizing integrity, trust and dependability. MH&W not only offers top-quality products and workmanship - we back them up with outstanding commitment and service. With a sincere attitude towards service, and the confidence to firmly stand behind our products, we've become quite flexible over the years. This flexibility allows us to maintain an ideal position in the industry: one that you can count on every time.

Engineering

At MH&W, we design all of our fixtures in house, to ensure the precision our customers deserve. Our design process begins with a new job startup committee, in which prints are reviewed by our tooling engineers, process engineers, and quality engineers. Preliminary fixture designs are then submitted to our management review team for approval.

MH&W utilizes Solidworks CAD with 3-D modeling capabilities and can import 3-D models from other CAD software programs. We use 3-D models to design fixtures and tooling for our CNC equipment. MH&W also uses Gibbs CAM software to produce tool paths for our machine tools.

MH&W actively participates in customer design review meetings. We help customers during the design process to eliminate costs up front. We also provide services such as rapid prototyping, CNC manufacturability recommendations, and

FMEA's.

Our engineers closely collaborate with the factory and our customer's design engineers to support their designs, analyze their applications, anticipate problems, and recommend possible solutions. Applying the latest technology and modern research tools, our engineers are able to respond promptly to complex tasks. The engineers strive to anticipate future trends so that new products will be available in a timely fashion.

Field Sales Representatives and Engineers

With a network of highly knowledgeable Field Sales Representatives based in organizations strategically placed across the United States, Canada and Mexico, MH&W is poised to provide competitive prices, quick reliable deliveries and unparalleled engineering assistance.

Six Sigma(六西格玛)

Companies need world class suppliers in today's competitive marketplace. MH&W continues to invest in the resources to meet our customers' demands of consistent quality, just-in-time delivery and constant improvement in the cost area.

MH&W has a full-time Six Sigma Black Belt training our employees in lean manufacturing principles. That's been the case for years. We also have dozens of Six Sigma Green Belts on staff. Using Six Sigma raises our company standards by adopting kaizen, lean manufacturing, cost improvement, structured new product development and project-based process changes both on the shop floor and in the MH&W offices.

Task: Search for useful information in the passage and complete the summary below. Fill in each blank with NO MORE THAN THREE WORDS.

MH&W International Corp. Profile

Founded in 1. _____, MH&W International Corp. is a 2. _____ organization in the United States, Canada and Mexico. The company consists of two operating divisions: 3. _____ and 4. _____. It can meet its customers' 5. _____ requirements and surpass their expectations. MH&W not only offers top-quality products and 6. _____, but also back them up with outstanding 7. _____. Besides, it operates as an exclusive engineering and marketing 8. _____ between several major 9. _____ and its customers. It offers Six Sigma training 10. _____ to its employees and raises its standards by using it.

任务 2: 商务文书翻译 (50 分)

内容：商务文书翻译

要求：阅读并理解所给商务文书；译文表达专业、术语准确，符合商务文体特征；内容完整，逻辑严谨，衔接流畅。

Section II 商务文书翻译(50 分)

Directions: Translate the following agenda into Chinese.

MH&W International Corp. Meeting of the Board of Directors(董事会)

Date: December 11, 2023

Time: 9:00 a.m. -11:00 a.m.

Location: Conference Room, 7th Floor MIT Building.

Agenda

1. Financial report -Mr. Lee (Vice President(副总裁) of Finance)

Report on last year's performance

2. Business plan -Mr. Blake (Vice President of Marketing)

Analysis of business plan for 2024, including income, budget(预算), and new clients.

3. New business -Mr. Smith (CEO)

Discussion of future cooperation with Sany Group(三一集团).

4. Travel policy - Mr. Smith (CEO)

Discussion of what and how employees are paid when travel for business purposes

(2) 实施条件

项目	基本实施条件	备注
场地	每个商务英语实训室配置 40 个操作台面和座位,每个实训室照明通风良好。	必备
设备	每个商务英语实训室配有 1 台服务器、40—50 台计算机,并安装 Office 办公软件,配置局域网。	必备
测评专家	每 40 名考生配备 1 名考评员。考评员要求具备至少二年以上从事国际贸易工作经验或三年以上商务英语实践教学指导经历。	必备

(3) 考核时量

考试时间：60 分钟

(4) 评分标准

模块总分		评价内容	配分	考核点	备注	
专业基本技能模块一：英语语言应用（总分100分，占总评分的30%）	职业素养与操作规范（10分）	职业素养（6分）	2分	(1) 具备外贸从业人员基本素质，认真严谨、耐心细致、恪守信誉、实事求是、服从安排，听从指挥、举止文明，记2分。	在考试过程中不服从安排、举止不当者，记0分。	
			2分	(2) 具备外贸从业人员良好的翻译素养，认真严谨，耐心细致，记2分。	考试过程中出现与上述能力及素养不符，扣1-2分。	
			2分	(3) 具备外贸从业人员良好的沟通能力、表达能力和合作意识，待人真诚礼貌，记2分。	考试过程中出现与上述能力及素养不符，扣1-2分。	
		操作规范（4分）	2分	(1) 具备使用办公设备和 Office 办公软件的能力，在考核过程中以及考核结束后，不私自更换电脑、不随意关闭或重启电脑，没征求监考老师同意不随意提前或推迟交卷，记2分。	若私自更换电脑、随意关闭或重启电脑，记0分。	
			2分	(2) 能严格遵守企业 6S 管理要求（整理、整顿、清扫、清洁、素养、安全），记2分。	若未遵守企业 6S 管理要求，记0分。	
		国际商务信息检索（40分）	10分	(1) 阅读并理解所给外贸公司介绍资料，检索、筛选有效信息，记10分。		
	(2) 补充完善信息要点，每空不超过3个单词，每空3分，共10空，记30分。			大小写错误每处扣0.5分；答案不完整每处扣1分；拼写错误每处计0分		
	作品（90分）		商务文书翻译（50分）	15分	(1) 能准确理解所给商务文书，语义信息理解正确，内容完整，记15分。	主要内容每缺失1处，扣2分
				15分	(2) 能熟练运用商务翻译技巧、国际贸易和英语语言综合知识，语言表达通顺，符合商务文体特征，记15分。	专业术语、贸易惯例、法规、条款等翻译错误，每2处错误扣1分。
				10分	(3) 语言表达通顺，语法、句型使用正确，记10分。	单词、语法每错3处扣1分。
				10分	(4) 译文表达准确，双语转换顺畅，体裁运用恰当，标点运用正确，记10分。	错别字、标点、句型表达，每2处错误扣1分。

20. 试题编号: 1-1-20 国际商务信息检索与商务文书翻译

(1) 任务描述

任务 1: 国际商务信息检索(40 分)

内容: 关键词检索

要求: 阅读并理解所给信息; 检索并筛选有效信息; 补充完善信息要点。

Section I 国际商务信息检索(40 分)

Directions: Read the following brief introduction to Merco Trading Co. from the official website of the company.

A Brief Introduction to Merco Trading Co.

Merco Trading Co., established in the year 2006, is one of the most acclaimed manufacturers and suppliers of high quality and precision engineered General Hardware Materials, Steel Materials and Engineering Goods. Being a sole proprietorship firm, we have always worked hard to achieve one of the best positions in the market hence offer our clients with a huge range of products that includes Forged & Rolled Bars, MS Fasteners, SS Fasteners, Drills / Taps / Reamers &

Machine Tools, Ferrous Alloys, Non Ferrous Metals, Hardware Material & Engineering Goods and many more.

In all these years of strong presence in the industry, we have successfully crafted a niche for ourselves in the industry and meet original requirements of people. People working with us are really hard working and believe in making efforts to take the company ahead on the paths of success. Belonging from different core domains all these people have something in common and that is enthusiasm and zeal to do something great and different by serving the clients to the highest level of their satisfaction.

Product Portfolio

We are one of the leading names in supplying general hardware materials and engineering products that include MS Structural Steels, MS Plates & Profiles, MS Seamless & ERW Pipes, MS Fasteners, Mild Steel Fasteners and Ferrous Alloys. We also offer Forged & Rolled Round Bars, SS Plates & Profiles, SS Fasteners, Non

Ferrous Metals, Drills & Taps & Reamers & Machine Tools and Customized Hardware Material & Engineering Goods. To ensure maximum client satisfaction, we offer all these products in various specifications as per the requirements of our clients.

Apart from this, we also cater for any special requirement in Ferrous & Non Ferrous metals.

Further, to ensure superior quality, we procure these products from reliable vendors and also arrange inspection of the materials at our end prior to dispatch either by the customer or any third party inspection agency.

Key features:

Corrosion resistant

Durable

Long functional life

Available in various specifications

Resistant to chemicals

Quality Assurance

We are a quality centric organization and try to maintain the highest standards of quality of our products at each level of product development. Our manufacturing abilities allow us to cater for the requirement of our clients in national and international market. Products offered by us passes through stringent quality tests at each stage of product development. These quality tests are conducted by highly qualified quality experts working with us, who have years of experience in this domain. We have designed set parameters for quality testing our products. To ensure standards of our products we offer certifications of Original Mill Test and are certified from NABL approved laboratory.

Industries Catered to

Our presence in the market has helped us in catering solutions of General Hardware Materials, Steel Materials and Engineering Goods. The expertise in manufacturing and exporting a range of these products have helped us in meeting requirements of our clients.

Industries that we cater to include:

Engineering related industry

Sugar industry

Metal industry

Petrochemical industry

Pumps industry

Plant & machine manufacturing industry

Vendor Base

Being distinguished supplier, we play a crucial role between manufacturers and our clients. Our association with reliable vendors has enabled us to supply superior range of general hardware materials and engineering products from reliable vendors. We select our vendors after thorough assessment on various factors.

Our selection process is based on following criteria:

Cost effectiveness

Quality range

Ethical business practices

Timely delivery

Further, to ensure optimum quality of products our procurement agents test the quality of material at their premises, then we again test the quality at our end prior to dispatch either by the Customer or any Third Party Inspection Agency. Our rich vendor base allows us to avoid any delay in delivering our product range and thereby maintaining our market credibility and trust of our clients.

Warehousing & Packaging

Being an able manufacturer, exporter and supplier of a wide assortment of General Hardware Materials, Steel Materials and Engineering Goods and for storing these products, we have developed a spacious and well segregated warehouse at our place. Segregation of the warehouse enables us to store the products easily and maintain their standards of quality at all times. Built on a large area, the warehouse is well connected to all major road, rail and sea routes of the country.

To pack our products to ensure their quality standards at time of delivery at clients end, we use raw materials of superior quality and engage professionally trained packaging experts. The packaging and warehousing works being practiced by us are supervised by packaging and warehouse supervisors.

Task: Search for useful information in the passage and complete the summary below. Fill in each blank with NO MORE THAN THREE WORDS.

Merco Trading Co. Profile

Merco Trading Co. is a 1. _____ of engineered General Hardware Materials, Steel Materials and 2. _____. The company procures from 3. _____ and also arranges 4. _____ of the materials at its end. Products

offered by it passes through stringent 5._____ at each stage of product development. The company's association with reliable vendors has enabled it to supply 6._____ range of products. And its rich 7._____ allows it to avoid any delay in 8._____ its product range. The company has developed a spacious and well segregated 9._____. It uses raw materials of superior quality and engages 10._____ packaging experts to pack the products.

任务 2：商务文书翻译（50 分）

内容：商务文书翻译

要求：阅读并理解所给商务文书；译文表达专业、术语准确，符合商务文体特征；内容完整，逻辑严谨，衔接流畅。

Section II 商务文书翻译(50 分)

Directions: Translate the following letter into Chinese.

Dear Sirs,

Enclosed is our new price list which will come into effect from the end of this month. You will see that we have increased our prices on most models as we are paying 10% more for our raw materials than we were paying last year. As you know, we take great pride in our reputation for high-quality products. We will not compromise that reputation because of rising costs. We hope you will understand our position and look forward to your orders.

Yours faithfully,
Lin Xiong
Sales Manager

(2) 实施条件

项目	基本实施条件	备注
场地	每个商务英语实训室配置 40 个操作台面和座位,每个实训室照明通风良好。	必备
设备	每个商务英语实训室配有 1 台服务器、40—50 台计算机,并安装 Office 办公软件,配置局域网。	必备
测评专家	每 40 名考生配备 1 名考评员。考评员要求具备至	必备

	少二年以上从事国际贸易工作经验或三年以上商务英语实践教学指导经历。	
--	-----------------------------------	--

(3) 考核时量

考试时间：60 分钟

(4) 评分标准

模块总分	评价内容	配分	考核点	备注	
专业基本技能模块一：英语语言应用（总分100分，占总评分的30%）	职业素养与操作规范（10分）	2分	(1) 具备外贸从业人员基本素质，认真严谨、耐心细致、恪守信誉、实事求是、服从安排，听从指挥、举止文明，记2分。	在考试过程中不服从安排、举止不当者，记0分。	
		2分	(2) 具备外贸从业人员良好的翻译素养，认真严谨，耐心细致，记2分。	考试过程中出现与所述能力及素养不符，扣1-2分。	
		2分	(3) 具备外贸从业人员良好的沟通能力、表达能力和合作意识，待人真诚礼貌，记2分。	考试过程中出现与所述能力及素养不符，扣1-2分。	
		2分	(1) 具备使用办公设备和 Office 办公软件的能力，在考核过程中以及考核结束后，不私自更换电脑、不随意关闭或重启电脑，没征求监考老师同意不随意提前或推迟交卷，记2分。	若私自更换电脑、随意关闭或重启电脑，记0分。	
		2分	(2) 能严格遵守企业 6S 管理要求（整理、整顿、清扫、清洁、素养、安全），记2分。	若未遵守企业 6S 管理要求，记0分。	
		10分	(1) 阅读并理解所给外贸公司介绍资料，检索、筛选有效信息，记10分。		
	作品（90分）	国际商务信息检索（40分）	30分	(2) 补充完善信息要点，每空不超过3个单词，每空3分，共10空，记30分。	大小写错误每处扣0.5分；答案不完整每处扣1分；拼写错误每处计0分
			15分	(1) 能准确理解所给商务文书，语义信息理解正确，内容完整，记15分。	主要内容每缺失1处，扣2分
		商务文书翻译（50分）	15分	(2) 能熟练运用商务翻译技巧、国际贸易和英语语言综合知识，语言表达通顺，符合商务文体特征，记15分。	专业术语、贸易惯例、法规、条款等翻译错误，每2处错误扣1分。
			10分	(3) 语言表达通顺，语法、句型使用正	单词、语法每错3

			确，记 10 分。	处扣 1 分。
		10 分	(4) 译文表达准确，双语转换顺畅，体裁运用恰当，标点运用正确，记 10 分。	错别字、标点、句型表达，每 2 处错误扣 1 分。

二、岗位核心技能模块项目一 —— 外贸业务磋商

1. 试题编号：2-1-1 外贸业务磋商——建立贸易关系

(1) 任务描述

任务 1：商务谈判对话设计

内容：建立贸易关系对话设计

要求：了解谈判双方背景，熟悉外贸业务流程和专业术语，灵活运用谈判策略，合理补充谈判对话，语言达到位，交流畅通，环节紧凑。

考试资料：

1. 出口方基本情况

Company	Hunan Provincial Light Industrial Products Corporation Ltd.
Url	http://www.chinavista.com/business/500/ch188.html
Office Address	No.4 East Wuyi Road, Changsha, Hunan, China
Zip code	410001
Phone	86-731-8 4447135
Fax	86-731-8 4447844

2. 进口方基本情况

Company	ALDI Group (Australia Branch)
Url	http://ALDI.us/index_ENU_HTML.htm
Office Address	Minchinbury Region, Locked Bag 56, St. Mary's Delivery

	Centre, NSW 2760, Australia
Phone	0061-433694502
Fax	0061-433694502

3. 出口方信息

After more than 30 years of great pains-taking development, the business of Hunan Provincial Light Industrial Products Corporation Ltd. (LIPC) has been increasingly enlarged. Now, its trade relations cover more than one hundred countries and regions; its total value of import and export reaches above 100,000,000US dollars. It has been awarded the honorable title of one of “the First 500 Enterprises in China” for four years continually.

Comprising twelve business departments, five branch companies, four factories and six Sino-overseas joint ventures, LIPC’s main business line includes: light industrial products, general merchandise, hardware, technology, porcelain, building material, textile and mechanism. Besides, LIPC also acts as an agent, under-taking processes with supplied samples, supplied drawings, or materials and compensation trade.

Recent years saw LIPC introducing technology, updating equipment, developing new products and improving the quality of products. “DH”, “DEYI” shoes, “FEITIEN” bags and cases, balls, “SEA GULL” batteries, “JIN BAO” tissue, “LOTUS” thermos etc. are greatly welcomed by customers all over the world.

抽考试题

Section I 外贸业务谈判 (50 分)

Directions: You are required to complete a negotiation based on the following situation with at least 80 words.

Situation: You (Tom Smith), Purchasing Manager of ALDI Group (Australia Branch), are visiting the Exhibition booth of Hunan Provincial Light Industrial Products Corporation Ltd.. Liu Li (the exporter), a sales representative, is receiving you. You wish to establish long-term business relations with the exporter, and are especially interested in one of the exporter’s products—SWG Lotus slippers.

You are required to finish the following tasks:

A: You (the importer) B: Liu Li (the exporter)

A: _____

(Greet the exporter, offer a business card and make self-introduction.)

B: Thank you! I’m pleased to meet you. Welcome to our booth. I’m Liu Li.

A: _____

(Give response and show appreciation.)

B: Let me show you around our booth.

A: _____

(Give comments to the booth.)

B: Thanks. On display are most of our latest products, and we are sure you'll be satisfied with them.

A: _____
(Show interest in the exporter's products and express your wish to establish business relations.)

B: You can trust us that we would provide the best quality products. We specialize in the export of slippers for more than 8 years and enjoy great popularity in this line.

A: _____
(State the specific type of the products that interests you most.)

B: We are enjoying an excellent reputation for our products both at home and abroad. SWG Lotus slippers are with great favor overseas. Here is some detailed information.

A: _____
(Provide Bank of China or local Chamber of Commerce as credit status reference.)

B: Thanks for your suggestion. We are willing to enter into business relationship with your company on the basis of equality and mutual benefit.

A: _____
(Promise to inquire as soon as possible.)

B: It will be a great pleasure if we can hear from you in the near future, and we'll then make an offer.

A: _____
(Show your desire to do business with the exporter.)

B: That's also exactly what I had in mind.

任务 2: 外贸英语函电撰写 (40 分)

内容: 建立贸易关系函电撰写

要求: 理解命题要求, 确定函电性质; 函电格式正确, 字数达标; 表达流畅, 文字通顺, 逻辑合理。

Section II 外贸英语函电撰写

Directions: You are required to write a letter based on the following situation with at least 100 words. (Note: Your letter should adopt the modified-block style.)

Situation: As the sales representative of Hunan Provincial Light Industrial Products Corporation Ltd., you are going to write to a client from ALDI Group (Australia Branch), who is in the market for slippers, with the hope of establishing business relations with him. (For more information about the two parties, please refer to the background information given above.)

The following aspects should be included in the letter:

Indicate the inside addresses of the sender, the receiver, the date, the complimentary close and the signature;

Specify the information channel to contact the client — the Internet information platform of Guangzhou Trade Fair;

Extend your wish to establish business relations for the product;

Introduce your status and main products;

Provide commodity list and several samples for reference.

(2) 实施条件

项目	基本实施条件	备注
场地	每个商务英语实训室配置 40 个操作台面和座位，每个实训室照明通风良好。	必备
设备	每个商务英语实训室配有 1 台服务器、40—50 台计算机，并安装 Office 办公软件，配置局域网。	必备
测评专家	每 40 名考生配备 1 名考评员。考评员要求具备至少二年以上从事国际贸易工作经验或三年以上商务英语实践教学指导经历。	必备

(3) 考核时量

考核时间：90 分钟

(4) 评分标准

模块总分		评价内容	配分	考核点	备注
岗位核心技能模块一：外贸业务磋商（总分 100 分，占总评分的 50%）	职业素养与操作规范（10 分）	职业素养（6 分）	2 分	具备外贸从业人员基本素质，认真严谨、耐心细致、恪守信誉、实事求是、服从安排，听从指挥、举止文明，记 2 分。	在考试过程中不服从安排、举止不得当者，记 0 分。
			2 分	具备外贸从业人员良好的谈判能力、外贸英语函电撰写能力和翻译能力，商务表达得体、规范到位，符合外贸行业对外贸业务、商务翻译、商务管理等相关岗位需求，记 2 分。	考试过程中出现与上述能力及素养不符，扣 1-2 分。
			2 分	具有良好的跨文化交流和商务礼仪等职业素养，在商务情境中具有敏锐的观察力和灵活的应变能力，记 2 分。	考试过程中出现与上述能力及素养不符，扣 1-2 分。
		操作规范（4 分）	2 分	具备使用办公设备和 Office 办公软件的能力，在考核过程中以及考核结束后，不私自更换电脑、不随意关闭或重启电脑，没征求监考老师同意不随意提前或推迟交卷，记 2 分。	若私自更换电脑、随意关闭或重启电脑，记 0 分。

		2分	能严格遵守企业 6S 管理要求（整理、整顿、清扫、清洁、素养、安全），记 2 分。	若未遵守企业 6S 管理要求，记 0 分。
作品 (90分)	外贸 业务 谈判 (50分)	15分	英语表达通顺，语法、句法使用正确，记 15 分。	单词、句型错误每 3 处扣 1 分。
		10分	应对得体，对话流转合理，记 10 分。	对话缺乏连贯性，每处酌情扣 1-2 分。
		10分	对话中能使用准确的与考核主题谈判的套语、术语记 10 分。	套语、术语搭配不合理，每处扣 0.5 分，搭配错误每处扣 1 分。
		15分	理解题目要求，信息点完整记 15 分。	信息点每缺失一处扣 1 分。
	外贸 英语 函电 撰写 (40分)	5分	函电格式完全正确，记 5 分。	日期、称呼语、结尾敬语、签名、排版每错 2 处扣 1 分。
		5分	字数达到要求，记 5 分。	每少 10 词扣 1 分。
		15分	语言表达通顺，语法、句型使用正确，记 15 分。	单词、语法每错 3 处扣 1 分。
		15分	理解题目要求，信息点完整，记 15 分。	信息点每缺失一处扣 1 分。

2. 试题编号：2-1-2 外贸业务磋商——付款方式谈判

(1) 任务描述

任务 1：商务谈判对话设计

内容：付款方式谈判对话设计

要求：了解谈判双方背景，熟悉外贸业务流程和专业术语，灵活运用谈判策略，合理补全谈判对话，语言表达到位，交流畅通，环节紧凑。

考试资料

1. 出口方基本情况

Company	Hunan Provincial Light Industrial Products Corporation Ltd.
---------	---

Url	http://www.chinavista.com/business/500/ch188.html
Office Address	No.4 East Wuyi Road, Changsha, Hunan, China
Zip code	410001
Phone	86-731-8 4447135
Fax	86-731-8 4447844

2. 进口方基本情况

Company	TJ Morris Ltd.
Url	http://www.tjmorris.co.uk/
Office Address	Axis Business Park, Gilmoos, Liverpool, Merseyside L11 0JA, U.K.
Phone	0151 530 2920
Fax	0151 530 2922

3. 出口方信息

After more than 30 years of great pains-taking development, the business of Hunan Provincial Light Industrial Products Corporation Ltd. (LIPC) has been increasingly enlarged. Now, its trade relations cover more than one hundred countries and regions; its total value of import and export reaches above 100,000,000US dollars. It has been awarded the honorable title of one of “the First 500 Enterprises in China” for four years continually.

Comprising twelve business departments, five branch companies, four factories and six Sino-overseas joint ventures, LIPC’s main business line includes: light industrial products, general merchandise, hardware, technology, porcelain, building material, textile and mechanism. Besides, LIPC also acts as an agent, under-taking processes with supplied samples, supplied drawings, or materials and compensation trade.

Recent years saw LIPC introducing technology, updating equipment, developing new products and improving the quality of products. “DH”, “DEYI” shoes, “FEITIEN” bags and cases, balls, “SEA GULL” batteries, “JIN BAO” tissue, “LOTUS” thermos etc. are greatly welcomed by customers all over the world.

抽考试题

Section I 外贸业务谈判 (50分)

Directions: You are required to complete a negotiation based on the following situation with at least 80 words.

Situation: Mr. Brown (the importer), representative of TJ Morris Ltd., is meeting with **you** (Wang Jun), Marketing Manager of Hunan Provincial Light Industrial Products Corporation Ltd. in your office. You have settled the price, quality and quantity on the commodity of Honyar electric switches. Now you are talking about the terms of payment.

You are required to finish the following tasks:

A: Mr. Brown (the importer) B: You (the exporter)

A: Well, let's talk about the terms of payment now.

B: _____

(State that you only accept irrevocable sight L/C.)

A: I see. Could you make an exception and accept D/A or D/P?

B: _____

(Insist on your original proposal.)

A: Letter of Credit would increase the cost of my import. When I open Letter of Credit with a bank, I have to pay a deposit.

B: _____

(Suggest consulting the bank to reduce the deposit.)

A: But there will be additional bank charges. It would help us greatly if you would accept D/A or D/P.

B: _____

(State the reason for asking for L/C (more protection to the exporter).)

A: If you agree to accept D/P, we can compromise on other terms.

B: _____

(Show regret for insisting on L/C.)

A: To meet you half way, what do you say if 50% by sight L/C and the balance by D/P?

B: _____

(Suggest the buyer to reduce their order this time if they don't accept L/C.)

A: Well, in that case, I'll issue the L/C in your favor as soon as I get home.

B: _____

(Inquire about the specific time of issuing L/C.)

A: Early next week. In the meantime, I hope that the goods can be dispatched promptly after you get my L/C.

B: _____

(Promise to deliver the goods on receiving L/C.)

A: OK. That's settled.

任务 2: 外贸英语函电撰写 (40 分)

内容: 付款方式谈判函电撰写

要求: 理解命题要求, 确定函电性质; 函电格式正确, 字数达标;

表达流畅, 文字通顺, 逻辑合理。

Section II 外贸英语函电撰写

Directions: You are required to write a letter based on the following situation with at least 100 words. (Note: Your letter should adopt the modified-block style.)

Situation: As the Sales Manager of Hunan Provincial Light Industrial Products Corporation Ltd., you are going to write to the Purchasing Manager from TJ Morris Ltd, who has placed an order for 600 boxes of electric switches, to extend your request for the terms of payment. (For more information about the two parties, please refer to the background information given above.)

The following aspects should be included in the letter:

Indicate the inside addresses of the sender, the receiver, the date, the complimentary close and the signature;

Extend your appreciation for the order and the client's intention to push the sales in his country;

Decline the client's request for payment under usance L/C;

Require the terms of payment---by confirmed irrevocable L/C at sight, with partial shipment not allowed and transshipment allowed;

Explain the reason you insist on L/C — your usual practice; Express your expectation from the addressee.

(2) 实施条件

项目	基本实施条件	备注
场地	每个商务英语实训室配置 40 个操作台面和座位，每个实训室照明通风良好。	必备
设备	每个商务英语实训室配有 1 台服务器、40—50 台计算机，并安装 Office 办公软件，配置局域网。	必备
测评专家	每 40 名考生配备 1 名考评员。考评员要求具备至少二年以上从事国际贸易工作经验或三年以上商务英语实践教学指导经历。	必备

(3) 考核时量

考核时间：90 分钟

(4) 评分标准

模块总分	评价内容	配分	考核点	备注
岗位核心	职业素养	2 分	具备外贸从业人员基本素质，认真严谨、耐心细致、恪守信誉、实事求是、服从安	在考试过程中不服从安排、举止不得

技能模块一：外贸业务磋商（总分100分，占总评分的50%）	与操作规范（10分）	（6分）		排，听从指挥、举止文明，记2分。	当者，记0分。	
		2分		具备外贸从业人员良好的谈判能力、外贸英语函电撰写能力和翻译能力，商务表达得体、规范到位，符合外贸行业对外贸业务、商务翻译、商务管理等相关岗位需求，记2分。	考试过程中出现与上述能力及素养不符，扣1-2分。	
		2分		具有良好的跨文化交流和商务礼仪等职业素养，在商务情境中具有敏锐的观察力和灵活的应变能力，记2分。	考试过程中出现与上述能力及素养不符，扣1-2分。	
		操作规范（4分）	2分		具备使用办公设备和 Office 办公软件的能力，在考核过程中以及考核结束后，不私自更换电脑、不随意关闭或重启电脑，没征求监考老师同意不随意提前或推迟交卷，记2分。	若私自更换电脑、随意关闭或重启电脑，记0分。
	2分			能严格遵守企业 6S 管理要求（整理、整顿、清扫、清洁、素养、安全），记2分。	若未遵守企业 6S 管理要求，记0分。	
	作品（90分）	外贸业务谈判（50分）	15分		英语表达通顺，语法、句法使用正确，记15分。	单词、句型错误每3处扣1分。
			10分		应对得体，对话流转合理，记10分。	对话缺乏连贯性，每处酌情扣1-2分。
			10分		对话中能使用准确的与考核主题谈判的套语、术语记10分。	套语、术语搭配不合理，每处扣0.5分，搭配错误每处扣1分。
			15分		理解题目要求，信息点完整记15分。	信息点每缺失一处扣1分。
		外贸英语函电撰写（40分）	5分		函电格式完全正确，记5分。	日期、称呼语、结尾敬语、签名、排版每错2处扣1分。
			5分		字数达到要求，记5分。	每少10词扣1分。
			15分		语言表达通顺，语法、句型使用正确，记15分。	单词、语法每错3处扣1分。
			15分		理解题目要求，信息点完整，记15分。	信息点每缺失一处扣1分。

3. 试题编号：2-1-3 外贸业务磋商——价格谈判

（1）任务描述

任务1：商务谈判对话设计

内容：价格谈判对话设计

要求：了解谈判双方背景，熟悉外贸业务流程和专业术语，灵活运用谈判策略，合理补全谈判对话，语言表达到位，交流畅通，环节紧凑。

考试资料

1. 出口方基本情况

Company	Hunan Provincial Light Industrial Products Corporation Ltd.
Url	http://www.chinavista.com/business/500/ch188.html
Office Address	No.4 East Wuyi Road, Changsha, Hunan, China
Zip code	410001
Phone	86-731-8 4447135
Fax	86-731-8 4447844

2. 进口方基本情况

Company	Foremost International Ltd.(Canada Branch)
Url	http://www.foremostgroups.com/page/contact
Office Address	5970 Chedworth Way, Unit A, Mississauga, Ontario, Canada
Toll free	888—256—7551
Phone	905—507—2005
Fax	905—507—2006
E-mail	foremostcanada@foremostgroups.com

3. 出口方信息

After more than 30 years of great pains-taking development, the business of Hunan Provincial Light Industrial Products Corporation Ltd. (LIPC) has been increasingly enlarged. Now, its trade relations cover more than one hundred countries and regions; its total value of import and export reaches above 100,000,000US dollars. It has been awarded the honorable title of one of “the First 500 Enterprises in China” for four years continually.

Comprising twelve business departments, five branch companies, four factories and six Sino-overseas joint ventures, LIPC's main business line includes: light industrial products, general merchandise, hardware, technology, porcelain, building material, textile and mechanism. Besides, LIPC also acts as an agent, under-taking processes with supplied samples, supplied drawings, or materials and compensation trade.

Recent years saw LIPC introducing technology, updating equipment, developing new products and improving the quality of products. "DH", "DEYI" shoes, "FEITIEN" bags and cases, balls, "SEA GULL" batteries, "JIN BAO" tissue, "LOTUS" thermos etc. are greatly welcomed by customers all over the world.

抽考试题

Section I 外贸业务谈判 (50分)

Directions: You are required to complete a negotiation based on the following situation with at least 80 words.

Situation: You (Tim Hill), representative of Foremost International Ltd., visit Wang Jun, Marketing Manager of Hunan Provincial Light Industrial Products Corporation Ltd. in Miss Wang's office. You have a negotiation about the price of biodegradable plastic cup.

You are required to finish the following tasks:

A: You (the importer)

B: Wang Jun (the exporter)

A: _____
(Give greetings and confirm having received the sample and ask about the price.)

B: Sure. For this model, we're offering USD 8000, CIF Boston.

A: _____
(Ask whether the price is for a carton or for a piece.)

B: No, of course not. USD 8000 per carton.

A: _____
(Ask the specific number of pieces in a carton.)

B: 10 pieces per carton.

A: _____
(Suggest FOB term and give reasons.)

B: I'm sorry, but we don't usually adopt FOB term.

A: _____
(Suggest CIF Toronto)

B: Yes, we can do that. We'll offer USD 7800, CIF Toronto.

A: _____
(Show your disagreement on the price (too high), and explain the reason)

B: But you must take the quality into consideration. Our furniture is of superior quality to those from other countries.

A: _____
(Explain that your client won't accept the price.)

B: Please understand that these offers are only open for three days. You may have to

decide soon.

A: _____
(Agree to reconsider.)

B: OK. please do not hesitate to contact me if you have decided.

任务 2: 外贸英语函电撰写 (40 分)

内容: 价格谈判函电撰写

要求: 理解命题要求, 确定函电性质; 函电格式正确, 字数达标;
表达流畅, 文字通顺, 逻辑合理。

Section II 外贸英语函电撰写

Directions: You are required to write a letter based on the following situation with at least 100 words. (Note: Your letter should adopt the modified-block style.)

Situation: As a sales representative of Hunan Provincial Light Industrial Products Corporation Ltd., you are going to write back to a client from Foremost International Ltd., who requested you to reduce your price by 10%. (For more information about the two parties, please refer to the background information given above.)

The following aspects should be included in the letter:

Indicate the inside addresses of the sender, the receiver, the date, the complimentary close and the signature;

Reply your client who thinks your quotation for the furniture is too high;

State your reasons for your quotation: good quality of your goods and a rise in the price of raw material;

Take your business relations into consideration; offer to reduce your quotation by 3%; Make a proposal for 1/4 down payment.

(2) 实施条件

项目	基本实施条件	备注
场地	每个商务英语实训室配置 40 个操作台面和座位, 每个实训室照明通风良好。	必备
设备	每个商务英语实训室配有 1 台服务器、40—50 台计算机, 并安装 Office 办公软件, 配置局域网。	必备
测评专家	每 40 名考生配备 1 名考评员。考评员要求具备至少二年以上从事国际贸易工作经验或三年以上商务英语实践教学指导经历。	必备

(3) 考核时量

考核时间：90 分钟

(4) 评分标准

模块总分		评价内容	配分	考核点	备注
岗位核心技能模块一：外贸业务磋商（总分 100 分，占总评分的 50%）	职业素养与操作规范（10 分）	职业素养（6 分）	2 分	具备外贸从业人员基本素质，认真严谨、耐心细致、恪守信誉、实事求是、服从安排，听从指挥、举止文明，记 2 分。	在考试过程中不服从安排、举止不当者，记 0 分。
			2 分	具备外贸从业人员良好的谈判能力、外贸英语函电撰写能力和翻译能力，商务表达得体、规范到位，符合外贸行业对外贸业务、商务翻译、商务管理等相关岗位需求，记 2 分。	考试过程中出现与上述能力及素养不符，扣 1-2 分。
			2 分	具有良好的跨文化交流和商务礼仪等职业素养，在商务情境中具有敏锐的观察力和灵活的应变能力，记 2 分。	考试过程中出现与上述能力及素养不符，扣 1-2 分。
		操作规范（4 分）	2 分	具备使用办公设备和 Office 办公软件的能力，在考核过程中以及考核结束后，不私自更换电脑、不随意关闭或重启电脑，没征求监考老师同意不随意提前或推迟交卷，记 2 分。	若私自更换电脑、随意关闭或重启电脑，记 0 分。
			2 分	能严格遵守企业 6S 管理要求（整理、整顿、清扫、清洁、素养、安全），记 2 分。	若未遵守企业 6S 管理要求，记 0 分。
	作品（90 分）	外贸业务谈判（50 分）	15 分	英语表达通顺，语法、句法使用正确，记 15 分。	单词、句型错误每 3 处扣 1 分。
			10 分	应对得体，对话流转合理，记 10 分。	对话缺乏连贯性，每处酌情扣 1-2 分。
			10 分	对话中能使用准确的与考核主题谈判的套语、术语记 10 分。	套语、术语搭配不合理，每处扣 0.5 分，搭配错误每处扣 1 分。
			15 分	理解题目要求，信息点完整记 15 分。	信息点每缺失一处扣 1 分。
		外贸英语函电撰写（40 分）	5 分	函电格式完全正确，记 5 分。	日期、称呼语、结尾敬语、签名、排版每错 2 处扣 1 分。
			5 分	字数达到要求，记 5 分。	每少 10 词扣 1 分。
		15 分	语言表达通顺，语法、句型使用正确，记	单词、语法每错 3	

	分)	15 分。	处扣 1 分。
	15 分	理解题目要求，信息点完整，记 15 分。	信息点每缺失一处扣 1 分。

4. 试题编号：2-1-4 外贸业务磋商技能——投诉与索赔谈判

(1) 任务描述

任务 1：商务谈判对话设计

内容：投诉与索赔谈判对话设计

要求：了解谈判双方背景，熟悉外贸业务流程和专业术语，灵活运用谈判策略，合理补充谈判对话，语言表达到位，交流畅通，环节紧凑。

考试资料

1. 出口方基本情况

Company	Hunan Provincial Light Industrial Products Corporation Ltd.
Url	http://www.chinavista.com/business/500/ch188.html
Office Address	No.4 East Wuyi Road, Changsha, Hunan, China
Zip code	410001
Phone	86-731-8 4447135
Fax	86-731-8 4447844

2. 进口方基本情况

Company	Seow Khim Polythelene Co Pte Ltd
Url	http://www.partyware.com.sg/index.htm
Office Address	28 Loyang Drive, SKP Industrial Building, Singapore
Phone	(+65) 6545 2828
Fax	(+65) 6542 1200

E-mail	export@skp.com.sg
--------	-------------------

3. 出口方信息

After more than 30 years of great pains-taking development, the business of Hunan Provincial Light Industrial Products Corporation Ltd. (LIPC) has been increasingly enlarged. Now, its trade relations cover more than one hundred countries and regions; its total value of import and export reaches above 100,000,000US dollars. It has been awarded the honorable title of one of “the First 500 Enterprises in China” for four years continually.

Comprising twelve business departments, five branch companies, four factories and six Sino-overseas joint ventures, LIPC’s main business line includes: light industrial products, general merchandise, hardware, technology, porcelain, building material, textile and mechanism. Besides, LIPC also acts as an agent, under-taking processes with supplied samples, supplied drawings, or materials and compensation trade.

Recent years saw LIPC introducing technology, updating equipment, developing new products and improving the quality of products. “DH”, “DEYI” shoes, “FEITIEN” bags and cases, balls, “SEA GULL” batteries, “JIN BAO” tissue, “LOTUS” thermos etc. are greatly welcomed by customers all over the world.

抽考试题

Section I 外贸业务谈判 (50 分)

Directions: You are required to complete a negotiation based on the following situation with at least 80 words.

Situation: David Smith, Purchasing Manager of Seow Khim Popythelene Co. Pte Ltd. visits **You** (Wang Juan), Marketing Manager of Hunan Provincial Light Industrial Products Corporation Ltd.. Mr. Smith is claiming for the damage of the dinnerware. But you believe it was possibly caused by rough handling.

You are required to finish the following tasks:

A: David Smith (the importer) B: You (the exporter)

A: Good morning, Mr. Wang.

B: _____

(Give greetings and show your willingness to offer help.)

A: I have something unpleasant to talk with you.

B: _____

(Show regret and propose the problem (quality of the dinnerware sets).)

A: Yes, the case is too serious to be overlooked, so I decide to have a face-to-face talk with you.

B: _____

(State your willingness to solve the problem and ask the arrival time.)

A: The containers we ordered arrived here last week. After re-inspection, we found lots of them were terribly crushed.

B: _____
 (Ask for the proof of the crushed goods.)
 A: We have the on-the-spot records and photos.
 B: _____
 (Explain the possible reason (rough handling))
 A: I can assure you there was no rough handling when the goods were unloaded. The damage might have happened during loading.
 B: _____
 (Put forward the suggestion (replacement).)
 A: Thank you for your understanding. Please take action quickly. Our clients are in urgent need of these goods.
 B: _____
 (Promise to cable home office and confirm the problem.)
 A: No problem. We might as well accept your proposal.
 B: _____
 (Make sure the specific time to solve the problem.)

任务 2: 外贸英语函电撰写 (40 分)

内容: 投诉与索赔谈判函电撰写

要求: 理解命题要求, 确定函电性质; 函电格式正确, 字数达标; 表达流畅, 文字通顺, 逻辑合理。

Section II 外贸英语函电撰写

Directions: You are required to write a letter based on the following situation with at least 100 words. (Note: Your letter should adopt the modified-block style.)

Situation: As the Marketing Manager of Seow Khim Polythelene Co Pte Ltd., you are going to write to Hunan Provincial Light Industrial Products Corporation Ltd. to claim for damages. **(For more information about the two parties, please refer to the background information given above.)**

The following aspects should be included in the letter:

Indicate the inside addresses of the sender, the receiver, the date, the complimentary close and the signature;

Specify the damages to the goods (High Density Polyethylene) caused by improper packing;

Present The Inspection Certificate issued by Singapore Exit and Entry Inspection Bureau;

Make a claim for US \$ 3000.00 as compensation or require to return the damaged goods;

Express your expectation to the addressee.

(2) 实施条件

项目	基本实施条件	备注
场地	每个商务英语实训室配置 40 个操作台面和座位，每个实训室照明通风良好。	必备
设备	每个商务英语实训室配有 1 台服务器、40—50 台计算机，并安装 Office 办公软件，配置局域网。	必备
测评专家	每 40 名考生配备 1 名考评员。考评员要求具备至少二年以上从事国际贸易工作经验或三年以上商务英语实践教学指导经历。	必备

(3) 考核时量

考核时间：90 分钟

(4) 评分标准

模块总分		评价内容	配分	考核点	备注
岗位核心技能模块一：外贸业务磋商（总分 100 分，占总评分的 50%）	职业素养与操作规范（10 分）	职业素养（6 分）	2 分	具备外贸从业人员基本素质，认真严谨、耐心细致、恪守信誉、实事求是、服从安排，听从指挥、举止文明，记 2 分。	在考试过程中不服从安排、举止不当者，记 0 分。
			2 分	具备外贸从业人员良好的谈判能力、外贸英语函电撰写能力和翻译能力，商务表达得体、规范到位，符合外贸行业对外贸业务、商务翻译、商务管理等相关岗位需求，记 2 分。	考试过程中出现与上述能力及素养不符，扣 1-2 分。
			2 分	具有良好的跨文化交流和商务礼仪等职业素养，在商务情境中具有敏锐的观察力和灵活的应变能力，记 2 分。	考试过程中出现与上述能力及素养不符，扣 1-2 分。
		操作规范（4 分）	2 分	具备使用办公设备和 Office 办公软件的能力，在考核过程中以及考核结束后，不私自更换电脑、不随意关闭或重启电脑，没征求监考老师同意不随意提前或推迟交卷，记 2 分。	若私自更换电脑、随意关闭或重启电脑，记 0 分。
			2 分	能严格遵守企业 6S 管理要求（整理、整顿、清扫、清洁、素养、安全），记 2 分。	若未遵守企业 6S 管理要求，记 0 分。
			15 分	英语表达通顺，语法、句法使用正确，记 15 分。	单词、句型错误每 3 处扣 1 分。
	作品（90 分）	外贸业务谈判（50 分）	10 分	应对得体，对话流转合理，记 10 分。	对话缺乏连贯性，每处酌情扣 1-2 分。

			10分	对话中能使用准确的与考核主题谈判的套语、术语记10分。	套语、术语搭配不合理，每处扣0.5分，搭配错误每处扣1分。
			15分	理解题目要求，信息点完整记15分。	信息点每缺失一处扣1分。
		外贸英语函电撰写(40分)	5分	函电格式完全正确，记5分。	日期、称呼语、结尾敬语、签名、排版每错2处扣1分。
			5分	字数达到要求，记5分。	每少10词扣1分。
			15分	语言表达通顺，语法、句型使用正确，记15分。	单词、语法每错3处扣1分。
			15分	理解题目要求，信息点完整，记15分。	信息点每缺失一处扣1分。

5. 试题编号：2-1-5 外贸业务磋商——包装与运输方式谈判

(1) 任务描述

任务1：商务谈判对话设计

内容：包装与运输方式谈判对话设计

要求：了解谈判双方背景，熟悉外贸业务流程和专业术语，灵活运用谈判策略，合理补全谈判对话，语言表达到位，交流畅通，环节紧凑。

考试资料

1. 出口方基本情况

Company	Hunan Provincial Light Industrial Products Corporation Ltd.
Url	http://www.chinavista.com/business/500/ch188.html
Office Address	No.4 East Wuyi Road, Changsha, Hunan, China
Zip code	410001
Phone	86-731-8 4447135
Fax	86-731-8 4447844

2. 进口方基本情况

Company	Naseeb International Corp.
Url	http://www.naseebintl.com/
Office Address	1600 Brimley Road, Units 3 & 4, Scarborough, ON M1P 3H1, Canada
Phone	1-866-848-9909, 416-292-9944
Fax	416-292-9943
E-mail	nic@naseebintl.com

3. 出口方信息

After more than 30 years of great pains-taking development, the business of Hunan Provincial Light Industrial Products Corporation Ltd. (LIPC) has been increasingly enlarged. Now, its trade relations cover more than one hundred countries and regions; its total value of import and export reaches above 100,000,000US dollars. It has been awarded the honorable title of one of “the First 500 Enterprises in China” for four years continually.

Comprising twelve business departments, five branch companies, four factories and six Sino-overseas joint ventures, LIPC’s main business line includes: light industrial products, general merchandise, hardware, technology, porcelain, building material, textile and mechanism. Besides, LIPC also acts as an agent, under-taking processes with supplied samples, supplied drawings, or materials and compensation trade.

Recent years saw LIPC introducing technology, updating equipment, developing new products and improving the quality of products. “DH”, “DEYI” shoes, “FEITIEN” bags and cases, balls, “SEA GULL” batteries, “JIN BAO” tissue, “LOTUS” thermos etc. are greatly welcomed by customers all over the world.

抽考试题

Section I 外贸业务谈判 (50 分)

Directions: You are required to complete a negotiation based on the following situation with at least 80 words.

Situation: **You** (Jack Brown), Purchasing Manager of Naseeb International Corp. visit Wang Jun, Marketing Manager of Hunan Provincial Light Industrial Products Corporation Ltd. You are talking about shipment of the goods sandals. Mr. Wang promises to make shipment by the end of May while you believe it is too late. You also discussed about partial shipment and transshipment.

You are required to finish the following tasks:

A: You (the importer)

B: Wang Jun (the exporter)

A: _____
 (Give greetings and ask about the earliest time of shipment.)

B: It usually takes us two months to make delivery.

A: _____
 (State you are in urgent need of the goods.)

B: Yes, we can understand. But we should get the goods ready; make out the documents and book shipping space. All these take time, so we can make prompt shipment by the end of May.

A: _____
 (Insist the delivery should be before the end of April to meet the selling season.)

B: Then how about partial shipment? We can ship whatever in ready to meet your urgent need instead of waiting for the whole lot to get ready.

A: _____
 (Show your refusal of partial shipment and explain the reason)

B: Well. We'll contact the factory and see if they can manage to advance delivery by a month.

A: _____
 (Suggest transshipment.)

B: No problem. So which port do you think it is suitable for transshipment?

A: _____
 (Confirm Toronto as the transferring port.)

B: Good. We will contact the shipping company to see if they have shipping space and the earliest shipping date.

A: _____
 (Insist that the shipment should be effected before the end of April.)

B: OK. We'll try our best to satisfy your shipment time.

A: _____
 (Express appreciation.)

B: Not at all.

任务 2: 外贸英语函电撰写 (40 分)

内容: 包装与运输方式谈判函电撰写:

要求: 理解命题要求, 确定函电性质; 函电格式正确, 字数达标; 表达流畅, 文字通顺, 逻辑合理。

Section II 外贸英语函电撰写

Directions: You are required to write a letter based on the following situation with at least 100 words. (Note: Your letter should adopt the modified-block style.)

Situation: As a sales representative of Hunan Provincial Light Industrial Products Corporation Ltd., you are going to write to a client from Naseeb International Corp. to inform him about the shipment of goods. **(For more**

information about the two parties, please refer to the background information given above.)

The following aspects should be included in the letter:

Indicate the inside addresses of the sender, the receiver, the date, the complimentary close and the signature;

Refer to the data as follows:

Contract No.	TG503726	Order No.	152
Name	FUXIA LEATHER PLATFORM SANDALS		
Model	BIAN-1002 sandals	Quantity	1,500 pairs
Value	USD41100.00	Specification	BIAN-1002
ETD	10 April, 2011	Name of Vessel	White Whale
Port of Loading	Shanghai	Port of Destination	Ontario

(2) 实施条件

项目	基本实施条件	备注
场地	每个商务英语实训室配置 40 个操作台面和座位，每个实训室照明通风良好。	必备
设备	每个商务英语实训室配有 1 台服务器、40—50 台计算机，并安装 Office 办公软件，配置局域网。	必备
测评专家	每 40 名考生配备 1 名考评员。考评员要求具备至少二年以上从事国际贸易工作经验或三年以上商务英语实践教学指导经历。	必备

(3) 考核时量

考核时间：90 分钟

(4) 评分标准

模块总分		评价内容	配分	考核点	备注
岗位核心技能	职业素养与操	职业素养 (6	2 分	具备外贸从业人员基本素质，认真严谨、耐心细致、恪守信誉、实事求是、服从安排，听从指挥、举止文明，记 2 分。	在考试过程中不服从安排、举止不当者，记 0 分。

模块一：外贸业务磋商（总分100分，占总评分的50%）	作规范（10分）	分）	2分	具备外贸从业人员良好的谈判能力、外贸英语函电撰写能力和翻译能力，商务表达得体、规范到位，符合外贸行业对外贸业务、商务翻译、商务管理等相关岗位需求，记2分。	考试过程中出现与上述能力及素养不符，扣1-2分。
			2分	具有良好的跨文化交流和商务礼仪等职业素养，在商务情境中具有敏锐的观察力和灵活的应变能力，记2分。	考试过程中出现与上述能力及素养不符，扣1-2分。
		操作规范（4分）	2分	具备使用办公设备和 Office 办公软件的能力，在考核过程中以及考核结束后，不私自更换电脑、不随意关闭或重启电脑，没征求监考老师同意不随意提前或推迟交卷，记2分。	若私自更换电脑、随意关闭或重启电脑，记0分。
			2分	能严格遵守企业 6S 管理要求（整理、整顿、清扫、清洁、素养、安全），记2分。	若未遵守企业 6S 管理要求，记0分。
	作品（90分）	外贸业务谈判（50分）	15分	英语表达通顺，语法、句法使用正确，记15分。	单词、句型错误每3处扣1分。
			10分	应对得体，对话流转合理，记10分。	对话缺乏连贯性，每处酌情扣1-2分。
			10分	对话中能使用准确的与考核主题谈判的套语、术语记10分。	套语、术语搭配不合理，每处扣0.5分，搭配错误每处扣1分。
			15分	理解题目要求，信息点完整记15分。	信息点每缺失一处扣1分。
		外贸英语函电撰写（40分）	5分	函电格式完全正确，记5分。	日期、称呼语、结尾敬语、签名、排版每错2处扣1分。
			5分	字数达到要求，记5分。	每少10词扣1分。
			15分	语言表达通顺，语法、句型使用正确，记15分。	单词、语法每错3处扣1分。
			15分	理解题目要求，信息点完整，记15分。	信息点每缺失一处扣1分。

6. 试题编号：2-1-6 外贸业务磋商——付款方式谈判

（1）任务描述

任务1：商务谈判对话设计

内容：付款方式谈判对话设计

要求：了解谈判双方背景，熟悉外贸业务流程和专业术语，灵活运用谈判策略，合理补全谈判对话，语言表达到位，交流畅通，环节紧凑。

考试资料

1. 出口方基本情况

Company	Hunan Cereals, Oils and Foodstuffs Import and Export Group Corp. Ltd.
Url	http://www.hunancof.com/yw/index.asp
Office Address	No. 2 Zhuyuan RD, Changsha, Hunan, China
Zip code	410001
E-mail	webmaster@hunancof.com

2. 进口方基本情况

Company	Novozymes(U.S.A)
Url	http://www.bioag.novozymes.com/en/products/Pages/default.aspx
Office Address	175 King Street, Seattle, WA 19103, U.S.A.
Phone	+1 9529133941
Toll-free	+1 8887445662
E-mail	djsv@novozymes.com

3. 出口方信息

Hunan Cereals, Oils and Foodstuffs Import and Export Group Corp., Ltd. is a solely state-owned enterprise affiliated to and supervised by State-owned Assets Supervision and Administration Commission of Hunan Province. By December 31, 2009, the total assets of the Group amounted to RMB ¥ 1.184 billion and the net assets amounted to RMB ¥ 753 million. Since the group founded in 1952, it has got very fast development in range of merchandise, volume and market of export and the assets has been increased continuously. Specializing in agricultural, by-products and processed products, the Group has always been an import and export enterprise of larger scale and better benefit for many years in Hunan province. Under the

background of restructure of the macro-economic and industrial structure, the Group is actively looking for changes and focusing on improving the industry chain of agricultural and by-products as well as developing new business. Besides the major traditional business, such as pig-raising & export and canned fruits export, the Group now has been involved in many fields such as production of agricultural and sideline products, import of medical equipment, domestic trade, property management and export agency service, initially located in well-situation with various business developing.

抽考试题

Section I 外贸业务谈判 (50 分)

Directions: You are required to complete a negotiation based on the following situation with at least 80 words.

Situation: Donald Williams, Marketing Manager of Novozymes, is meeting with **You** (Deng Liang), Marketing Manager of Hunan Cereals, Oils and Foodstuffs Import and Export Group Corp. Ltd. in your office. You have settled the price, quality and quantity on the commodity of Purple Speckled Kidney Beans. Now you are talking about the terms of payment.

You are required to finish the following tasks:

A: Donald Williams (the importer) B: You, Deng Liang (the exporter)

A: Good morning, Mr. Deng. It is great we settled the price, quality and quantity yesterday.

B: _____
(Give greetings.)

A: So shall we move on to terms of payment?

B: _____
(Ask about terms of payment)

A: I suppose D/P or D/A should be adopted as the payment terms this time.

B: _____
(Explain your usual practice (by confirmed and irrevocable letter of credit).)

A: Could you make an exception this time? It would help us greatly if you would accept it.

B: _____
(Insist on payment by L/C.)

A: In order to conclude the business, I hope you'll meet me half way. What about 50% by L/C and the balance by D/P?

B: _____
(Stress L/C is the only term of payment to be accepted.)

A: OK. Is the credit at sight or after sight?

B: _____
(Ask for L/C at sight.)

A: Could you accept a Usance L/C, say 30 days or 60 days after sight? If you cannot be more flexible, we won't accept your terms of payment.

B: _____
(Accept 30 days L/C only for this transaction.)

A: OK, thank you for your kindness.

B: _____
(Urge the L/C shall reach in early May.)

A: We will take care.

任务 2: 外贸英语函电撰写 (40 分)

内容: 付款方式谈判函电撰写

要求: 理解命题要求, 确定函电性质; 函电格式正确, 字数达标;
表达流畅, 文字通顺, 逻辑合理。

Section II 外贸英语函电撰写

Directions: You are required to write a letter based on the following situation with at least 100 words. (Note: Your letter should adopt the modified-block style.)

Situation: As the Purchasing Manager of Novozymes, you are going to write to the Sales Manager from Hunan Cereals, Oils and Foodstuffs Import and Export Group Corp. Ltd., to ask for the amendment of terms of payment for the deal of Purple Speckled Kidney Beans. (For more information about the two parties, please refer to the background information given above.)

The following aspects should be included in the letter:

Indicate the inside addresses of the sender, the receiver, the date, the complimentary close and the signature;

Provide the previous terms of payment---confirmed, irrevocable letter of credit;

State the situation ---tie-up of funds for three or four months owing to this term;
State the difficulties of payment under this term---tight money condition and high bank interest;

Propose either “Cash against Documents on arrival of goods” or “Drawing on us at three months’ sight”.

(2) 实施条件

项目	基本实施条件	备注
场地	每个商务英语实训室配置 40 个操作台面和座位, 每个实训室照明通风良好。	必备
设备	每个商务英语实训室配有 1 台服务器、40—50 台计算机, 并安装 Office 办公软件, 配置局域网。	必备
测评专家	每 40 名考生配备 1 名考评员。考评员要求具备至少二年以上从事国际贸易工作经验或三年以上商务英语实践教	必备

	学指导经历。	
--	--------	--

(3) 考核时量

考核时间：90 分钟

(4) 评分标准

模块总分	评价内容	配分	考核点	备注	
岗位核心技能模块一：外贸业务磋商（总分 100 分，占总评分的 50%）	职业素养与操作规范（10 分）	2 分	具备外贸从业人员基本素质，认真严谨、耐心细致、恪守信誉、实事求是、服从安排，听从指挥、举止文明，记 2 分。	在考试过程中不服从安排、举止不当者，记 0 分。	
		2 分	具备外贸从业人员良好的谈判能力、外贸英语函电撰写能力和翻译能力，商务表达得体、规范到位，符合外贸行业对外贸业务、商务翻译、商务管理等相关岗位需求，记 2 分。	考试过程中出现与所述能力及素养不符，扣 1-2 分。	
		2 分	具有良好的跨文化交流和商务礼仪等职业素养，在商务情境中具有敏锐的观察力和灵活的应变能力，记 2 分。	考试过程中出现与所述能力及素养不符，扣 1-2 分。	
		2 分	具备使用办公设备和 Office 办公软件的能力，在考核过程中以及考核结束后，不私自更换电脑、不随意关闭或重启电脑，没征求监考老师同意不随意提前或推迟交卷，记 2 分。	若私自更换电脑、随意关闭或重启电脑，记 0 分。	
		2 分	能严格遵守企业 6S 管理要求（整理、整顿、清扫、清洁、素养、安全），记 2 分。	若未遵守企业 6S 管理要求，记 0 分。	
		15 分	英语表达通顺，语法、句法使用正确，记 15 分。	单词、句型错误每 3 处扣 1 分。	
	作品（90 分）	外贸业务谈判（50 分）	10 分	应对得体，对话流转合理，记 10 分。	对话缺乏连贯性，每处酌情扣 1-2 分。
			10 分	对话中能使用准确的与考核主题谈判的套语、术语记 10 分。	套语、术语搭配不合理，每处扣 0.5 分，搭配错误每处扣 1 分。
			15 分	理解题目要求，信息点完整记 15 分。	信息点每缺失一处扣 1 分。
		外贸英语	5 分	函电格式完全正确，记 5 分。	日期、称呼语、结尾敬语、签名、排

	函电 撰写 (40 分)			版每错2处扣1分。
		5分	字数达到要求,记5分。	每少10词扣1分。
		15分	语言表达通顺,语法、句型使用正确,记15分。	单词、语法每错3处扣1分。
		15分	理解题目要求,信息点完整,记15分。	信息点每缺失一处扣1分。

7. 试题编号: 2-1-7 外贸业务磋商——投诉与索赔谈判

(1) 任务描述

任务1: 商务谈判对话设计

内容: 投诉与索赔谈判对话设计

要求: 了解谈判双方背景,熟悉外贸业务流程和专业术语,灵活运用谈判策略,合理补充谈判对话,语言达到位,交流畅通,环节紧凑。

考试资料

1. 出口方基本情况

Company	Hunan Cereals, Oils and Foodstuffs Import and Export Group Corp. Ltd.
Url	http://www.hunancof.com/yw/index.asp
Office Address	No. 2 Zhuyuan RD, Changsha, Hunan, China
Zip code	410001
E-mail	webmaster@hunancof.com

2. 进口方基本情况

Company	Whole Foods Market
Url	http://www.wholefoodsmarket.com/
Office Address	105 Mason Street, Austin TE 15002, U.S.A.
Phone	+1-202-328 2516

Fax	+1-202-328 2515
-----	-----------------

3. 出口方信息

Hunan Cereals, Oils and Foodstuffs Import and Export Group Corp., Ltd. is a solely state-owned enterprise affiliated to and supervised by State-owned Assets Supervision and Administration Commission of Hunan Province. By December 31, 2009, the total assets of the Group amounted to RMB ¥ 1.184 billion and the net assets amounted to RMB ¥ 753 million. Since the group founded in 1952, it has got very fast development in range of merchandise, volume and market of export and the assets has been increased continuously. Specializing in agricultural, by-products and processed products, the Group has always been an import and export enterprise of larger scale and better benefit for many years in Hunan province. Under the background of restructure of the macro-economic and industrial structure, the Group is actively looking for changes and focusing on improving the industry chain of agricultural and by-products as well as developing new business. Besides the major traditional business, such as pig-raising & export and canned fruits export, the Group now has been involved in many fields such as production of agricultural and sideline products, import of medical equipment, domestic trade, property management and export agency service, initially located in well-situation with various business developing.

抽考试题

Section I 外贸业务谈判 (50 分)

Directions: You are required to complete a negotiation based on the following situation with at least 80 words.

Situation: Mr. Miller, Purchasing Manager of Whole Foods Market, is calling **You** (Deng Liang), Marketing Manager of Hunan Cereals, Oils and Foodstuffs Import and Export Group Corp. Ltd. Mr. Miller is complaining to you of the short shipment and water damage on the commodity of Sushi Rice, and demand compensation.

You are required to finish the following tasks:

A: Mr. Miller (the importer)

B: You (the exporter)

A: Hello, I'd like to speak to Mr. Deng.

B: _____
(Answer the phone.)

A: Hello, Mr. Deng. This is Miller. How are you?

B: _____
(Greet and offer help.)

A: I'm calling to tell you that we are dissatisfied with the state of the goods of Sushi Rice.

B: _____
(Show your attitude and inquire the problem.)

A: We placed an order for Sushi Rice for 500MT, but when we received them, we

found there was a short shipment of 50 bags. And still 10 bags are water damaged.

B: _____
(Promise to solve the problem after a close investigation.)

A: I'm afraid you should compensate us by 3% of the total amount according to the contract and ship those damaged rice back and refund the payment.

B: _____
(Suggest selling the damaged goods at a lower price.)

A: You mean we'll dispose of those inferior goods in Austin, don't you?

B: _____
(Agree to ship the same damaged quantity in early January.)

A: You have to make it clear at what price we'll sell them. I think the price should be at least half of the original.

B: _____
(Agree to compensate according to the contract.)

A: That's good. Let's settle then.

B: _____
(Show your appreciation and end the call.)

A: Bye.

任务 2: 外贸英语函电撰写 (40 分)

内容: 投诉与索赔谈判函电撰写

要求: 理解命题要求, 确定函电性质; 函电格式正确, 字数达标; 表达流畅, 文字通顺, 逻辑合理。

Section II 外贸英语函电撰写

Directions: You are required to write a letter based on the following situation with at least 100 words. (Note: Your letter should adopt the modified-block style.)

Situation: As the Purchasing Manager of Whole Foods Market, you are going to write to the Marketing Manager from Hunan Cereals, Oils and Foodstuffs Import and Export Group Corp. Ltd., lodging a claim for the damage of 100 bags of Sushi Rice under the order HCOF-11108, which has been shipped per S/S "Princess" from Guangzhou. (For more information about the two parties, please refer to the background information given above.)

The following aspects should be included in the letter:

Indicate the inside addresses of the sender, the receiver, the date, the complimentary close and the signature;

Provide basic information about the shipment of goods being received;

Provide detailed situations of the damage of the goods—rice being dampened and even mildewed owing to broken packages;

State the probable reason of the damage—improper packing;

Provide the survey report to illustrate more information about the damage;

Require the rice to be replaced or will lodge a claim;
Demand immediate attention to this matter.

(2) 实施条件

项目	基本实施条件	备注
场地	每个商务英语实训室配置 40 个操作台面和座位，每个实训室照明通风良好。	必备
设备	每个商务英语实训室配有 1 台服务器、40—50 台计算机，并安装 Office 办公软件，配置局域网。	必备
测评专家	每 40 名考生配备 1 名考评员。考评员要求具备至少二年以上从事国际贸易工作经验或三年以上商务英语实践教学指导经历。	必备

(3) 考核时量

考核时间：90 分钟

(4) 评分标准

模块总分	评价内容	配分	考核点	备注
岗位核心技能模块一：外贸业务磋商（总分 100 分，占总评分的 50%）	职业素养与操作规范（10 分）	2 分	具备外贸从业人员基本素质，认真严谨、耐心细致、恪守信誉、实事求是、服从安排，听从指挥、举止文明，记 2 分。	在考试过程中不服从安排、举止不当者，记 0 分。
		2 分	具备外贸从业人员良好的谈判能力、外贸英语函电撰写能力和翻译能力，商务表达得体、规范到位，符合外贸行业对外贸业务、商务翻译、商务管理等相关岗位需求，记 2 分。	考试过程中出现与上述能力及素养不符，扣 1-2 分。
		2 分	具有良好的跨文化交流和商务礼仪等职业素养，在商务情境中具有敏锐的观察力和灵活的应变能力，记 2 分。	考试过程中出现与上述能力及素养不符，扣 1-2 分。
	操作规范（4 分）	2 分	具备使用办公设备和 Office 办公软件的能力，在考核过程中以及考核结束后，不私自更换电脑、不随意关闭或重启电脑，没征求监考老师同意不随意提前或推迟交卷，记 2 分。	若私自更换电脑、随意关闭或重启电脑，记 0 分。
		2 分	能严格遵守企业 6S 管理要求（整理、整顿、清扫、清洁、素养、安全），记 2 分。	若未遵守企业 6S 管理要求，记 0 分。

作品 (90分)	外贸 业务 谈判 (50分)	15分	英语表达通顺,语法、句法使用正确,记15分。	单词、句型错误每3处扣1分。
		10分	应对得体,对话流转合理,记10分。	对话缺乏连贯性,每处酌情扣1-2分。
		10分	对话中能使用准确的与考核主题谈判的套语、术语记10分。	套语、术语搭配不合理,每处扣0.5分,搭配错误每处扣1分。
		15分	理解题目要求,信息点完整记15分。	信息点每缺失一处扣1分。
	外贸 英语 函电 撰写 (40分)	5分	函电格式完全正确,记5分。	日期、称呼语、结尾敬语、签名、排版每错2处扣1分。
		5分	字数达到要求,记5分。	每少10词扣1分。
		15分	语言表达通顺,语法、句型使用正确,记15分。	单词、语法每错3处扣1分。
		15分	理解题目要求,信息点完整,记15分。	信息点每缺失一处扣1分。

8. 试题编号: 2-1-8 外贸业务磋商——建立贸易关系

(1) 任务描述

任务 1: 商务谈判对话设计

内容: 建立贸易关系对话设计

要求: 了解谈判双方背景,熟悉外贸业务流程和专业术语,灵活运用谈判策略,合理补全谈判对话,语言表达到位,交流畅通,环节紧凑。

考试资料

1. 出口方基本情况

Company	BROAD Air Quality Technology Group
Url	http://www.broad.com/

Office Address	Yuanda Town Yuanda 3 rd road, Changsha, Hunan, China
Zip code	410138
Phone	086-0731-84086688
Fax	086-0731-84552000
E-mail	css@broad.net

2. 进口方基本情况

Company	Onninen Group
Url	http://www.onninen.com
Office Address	Mittalinja 1, FI-01260 Vantaa, Finland
Phone	358 (0)204 85 5111
Fax	358 (0)204 85 5500
E-mail	infofinland@onninen.com

3. 出口方信息

BROAD Air Quality Technology Group is an enterprise based on the vision of unique technologies and philosophy of preserving life. All BROAD products and services have essentially optimized human life and the environment of the earth. BROAD Air Conditioning Equipment Co. Ltd. supplies no-electric central air conditioning powered by natural gas and waste heat as well as packaged water distribution system.

BROAD Energy Utilization Co. Ltd. provides energy management contract service, district cooling-heating-power system (CHP) investment, building and operation.

BROAD Sustainable Building Technology Co. Ltd. provides factory-made sustainable building with level 9 earthquake resistances, with 6 times material less, 5time energy efficient, and 20 times air purification.

BROAD Air Quality Technology Group headquartered in Changsha, China, has already exported products to more than 70 countries.

Company Development Path

On June 5, 1988, using USD 3,000 the company was registered in Chenzhou, Hunan to develop heating equipment.

In 1992, the company relocated to Changsha to start producing large scale non-electric central air conditioning chillers and equipment.

In 1998 the company's non-electric air conditioners entered into the international market.

In 1999 the company began producing packaged central air conditioning systems.

In 2005 the company began producing air quality products, which are now sold in more than 60 countries around the world.

Products

The complete set of Central Air Conditioning Equipment (Including hot water, to automate a building)

Services

After Sales Service, Trusteeship Service, EMC (Engineering Design Consulting)

Value

Healthy, Energy Efficient, Cost Saving

Comments from Premier Wen Jiabao

“BROAD non-electric air conditioning is the Circular Economy.”

BROAD is not a common company which has made a special contribution to the country.

抽考试题

Section I 外贸业务谈判 (50 分)

Directions: You are required to complete a negotiation based on the following situation with at least 80 words.

Situation: In the Guangzhou Fair, **You** (Matthew Smith), Purchasing Manager of Onninen Group visit Ye Tong, sales representative of BROAD Air Quality Technology Group. You introduce your companies and wish to establish long-term business relationship with the exporter.

You are required to finish the following tasks:

A: You (the importer)

B: Ye Tong (the exporter)

A: _____

(Greet B and make self introduction.)

B: Good morning, Mr. Smith. I'm Ye Tong. Welcome to our company.

A: _____

(Show your willingness to establish business relations)

B: Thank you. Can you give me a brief introduction to your company?

A: _____

(Introduce your company(established 30 years ago, with 3000 workers and 7 abroad branch offices).)

B: What products do you mainly deal with?

A: _____

(Introduce your main products; (electronics, lighting and heating).)

B: Great. We are in urgent need of these goods now. I think there will be bright prospects for us.

A: _____

(State your view on their company (famous and reputable).)

B: Thank you. I believe close cooperation between us will bring substantial mutual

benefits.

A: _____
(Provide National Bank or local Chamber of Commerce for credit status.)

B: Thank you for your information. I expect business will be developed between our two companies by our joint efforts,.

A: _____
(Promise to send a report home and make a specific inquiry.)

B: We'll then make an offer as soon as possible.

A: _____
(Show your appreciation.)

B: You're welcome.

任务 2: 外贸英语函电撰写 (40 分)

内容: 建立贸易关系函电撰写

要求: 理解命题要求, 确定函电性质; 函电格式正确, 字数达标; 表达流畅, 文字通顺, 逻辑合理。

Section II 外贸英语函电撰写

Directions: You are required to write a letter based on the following situation with at least 100 words. (Note: Your letter should adopt the modified-block style.)

Situation: As a sales representative of BROAD Air Quality Technology Group, you are going to write to a client from Onninen Group, who was introduced by the Commercial Counselor's Office in Finland, with the hope of establishing business relations with him. **(For more information about the two parties, please refer to the background information given above.)**

The following aspects should be included in the letter:

Indicate the inside addresses of the sender, the receiver, the date, the complimentary close and the signature;

Provide the information channel;

Extend your wish to establish business relations;

Introduce your company and main products;

Provide commodity books and two samples: Two-Way Motor Valve BVS20-2-16 Valve (20mm) and Two-Way Motor Valve BVS125-2-16 Valve (125mm) for reference;

Invite the client to visit your website to gain more information; Invite the importer to make enquiries.

(2) 实施条件

项目	基本实施条件	备注
----	--------	----

场地	每个商务英语实训室配置 40 个操作台面和座位，每个实训室照明通风良好。	必备
设备	每个商务英语实训室配有 1 台服务器、40—50 台计算机，并安装 Office 办公软件，配置局域网。	必备
测评专家	每 40 名考生配备 1 名考评员。考评员要求具备至少二年以上从事国际贸易工作经验或三年以上商务英语实践教学指导经历。	必备

(3) 考核时量

考核时间：90 分钟

(4) 评分标准

模块总分		评价内容	配分	考核点	备注
岗位核心技能模块一：外贸业务磋商（总分 100 分，占总评分的 50%）	职业素养与操作规范（10 分）	职业素养（6 分）	2 分	具备外贸从业人员基本素质，认真严谨、耐心细致、恪守信誉、实事求是、服从安排，听从指挥、举止文明，记 2 分。	在考试过程中不服从安排、举止不得当者，记 0 分。
			2 分	具备外贸从业人员良好的谈判能力、外贸英语函电撰写能力和翻译能力，商务表达得体、规范到位，符合外贸行业对外贸业务、商务翻译、商务管理等相关岗位需求，记 2 分。	考试过程中出现与上述能力及素养不符，扣 1-2 分。
			2 分	具有良好的跨文化交流和商务礼仪等职业素养，在商务情境中具有敏锐的观察力和灵活的应变能力，记 2 分。	考试过程中出现与上述能力及素养不符，扣 1-2 分。
		操作规范（4 分）	2 分	具备使用办公设备和 Office 办公软件的能力，在考核过程中以及考核结束后，不私自更换电脑、不随意关闭或重启电脑，没征求监考老师同意不随意提前或推迟交卷，记 2 分。	若私自更换电脑、随意关闭或重启电脑，记 0 分。
			2 分	能严格遵守企业 6S 管理要求（整理、整顿、清扫、清洁、素养、安全），记 2 分。	若未遵守企业 6S 管理要求，记 0 分。
	作品（90 分）	外贸业务谈判（50 分）	15 分	英语表达通顺，语法、句法使用正确，记 15 分。	单词、句型错误每 3 处扣 1 分。
			10 分	应对得体，对话流转合理，记 10 分。	对话缺乏连贯性，每处酌情扣 1-2 分。
			10 分	对话中能使用准确的与考核主题谈判的	套语、术语搭配不

				套语、术语记 10 分。	合理，每处扣 0.5 分，搭配错误每处扣 1 分。
			15 分	理解题目要求，信息点完整记 15 分。	信息点每缺失一处扣 1 分。
		外贸 英语 函电 撰写 (40 分)	5 分	函电格式完全正确，记 5 分。	日期、称呼语、结尾敬语、签名、排版每错 2 处扣 1 分。
			5 分	字数达到要求，记 5 分。	每少 10 词扣 1 分。
			15 分	语言表达通顺，语法、句型使用正确，记 15 分。	单词、语法每错 3 处扣 1 分。
			15 分	理解题目要求，信息点完整，记 15 分。	信息点每缺失一处扣 1 分。

9. 试题编号：2-1-9 外贸业务磋商——价格谈判

(1) 任务描述

任务 1：商务谈判对话设计

内容：价格谈判对话设计

要求：了解谈判双方背景，熟悉外贸业务流程和专业术语，灵活运用谈判策略，合理补全谈判对话，语言表达到位，交流畅通，环节紧凑。

考试资料

1. 出口方基本情况

Company	BROAD Air Quality Technology Group
Url	http://www.broad.com/
Office Address	Yuanda Town Yuanda 3 rd road, Changsha, Hunan, China
Zip code	410138
Phone	086-0731-84086688
Fax	086-0731-84552000

E-mail	css@broad.net
--------	---------------

2. 进口方基本情况

Company	Innovair Corporation
Url	http://www.innovair.com/
Office Address	Av. paeo de La Reforma No. 350, Piso 11 Colonia Juarez, Mexico
Phone	(55) 9171-8465
Fax	(55) 9171-8465
E-mail	info@innovair.com

3. 出口方信息

BROAD Air Quality Technology Group is an enterprise based on the vision of unique technologies and philosophy of preserving life. All BROAD products and services have essentially optimized human life and the environment of the earth. BROAD Air Conditioning Equipment Co. Ltd. supplies no-electric central air conditioning powered by natural gas and waste heat as well as packaged water distribution system.

BROAD Energy Utilization Co. Ltd. provides energy management contract service, district cooling-heating-power system (CHP) investment, building and operation.

BROAD Sustainable Building Technology Co. Ltd. provides factory-made sustainable building with level 9 earthquake resistances, with 6 times material less, 5time energy efficient, and 20 times air purification.

BROAD Air Quality Technology Group headquartered in Changsha, China, has already exported products to more than 70 countries.

Company Development Path

On June 5, 1988, using USD 3,000 the company was registered in Chenzhou, Hunan to develop heating equipment.

In 1992, the company relocated to Changsha to start producing large scale non-electric central air conditioning chillers and equipment.

In 1998 the company's non-electric air conditioners entered into the international market.

In 1999 the company began producing packaged central air conditioning systems.

In 2005 the company began producing air quality products, which are now sold in more than 60 countries around the world.

Products

The complete set of Central Air Conditioning Equipment (Including hot water, to

automate a building)

Services

After Sales Service, Trusteeship Service, EMC (Engineering Design Consulting)

Value

Healthy, Energy Efficient, Cost Saving

Comments from Premier Wen Jiabao

“BROAD non-electric air conditioning is the Circular Economy.”

BROAD is not a common company which has made a special contribution to the country.

抽考试题

Section I 外贸业务谈判 (50 分)

Directions: You are required to complete a negotiation based on the following situation with at least 80 words.

Situation: You (Edward Bush), Purchasing Manager of Innovair Corporation visit Wang Jun, Manager of Sales & Marketing Department of BROAD Air Quality Technology Group. You are interested in the items of BY50, BY300 and BY1000.

You are required to finish the following tasks:

A: You, Edward Bush (the importer) B: Wang Jun (the exporter)

A: _____
(Greet and express your desire to see the latest products.)

B: Good afternoon, Mr. Bush. Would you tell us what items you are interested in?

A: _____
(Show your interest in the items of BY50, BY300 and BY1000.)

B: What quantity do you require?

A: _____
(State your order (three sets of BY50, five sets of BY300 and five sets of BY1000) and ask for the lowest price.)

B: We can offer you USD 4700 per item for the first two and USD 5500 per item for the third.

A: _____
(Suggest bringing down the price at least by 10%.)

B: Ten percent? That would be difficult. I'm afraid we couldn't accept those terms. As you know, the Broad is one of the best-known brands in China. Every year, we export thousands of them to more than 50 countries and regions.

A: _____
(Emphasize the price of air condition indoor units is falling.)

B: I know the prices of some other air condition indoor units are going down, but ours are selling quite well because of its high quality and good reputation.

A: _____
(Suggest cutting the price respectively.)

B: I suggest we meet each other half way. I can offer you USD 4200 per item for the first and USD 5200 per item for the third but USD 4700 per item for the second. I

hope you can accept that.

A: _____

(Ask about the delivery.)

B: As a rule, we'll deliver the goods within one month after receiving your letter of credit.

A: _____

(Indicate that you'll fax home and discuss the details tomorrow morning.)

B: OK. See you tomorrow.

任务 2: 外贸英语函电撰写 (40 分)

内容: 价格谈判函电撰写

要求: 理解命题要求, 确定函电性质; 函电格式正确, 字数达标; 表达流畅, 文字通顺, 逻辑合理。

Section II 外贸英语函电撰写

Directions: You are required to write a letter based on the following situation with at least 100 words. (Note: Your letter should adopt the modified-block style.)

Situation: As a sales representative of BROAD Air Quality Technology Group, you are going to make an offer to a client from Innovair Corporation, who made an inquiry concerning your pumps. (For more information about the two parties, please refer to the background information given above.)

The following aspects should be included in the letter:

Indicate the inside addresses of the sender, the receiver, the date, the complimentary close and the signature;

Term	CFR Mexico		
Type	specification	quantity	Unit price
BY50 type	Pump set for 582kW/165Rt chillers	3 sets	USD 4,200.00
BY300 type	Pump set for 3489kW/992Rt chillers	5 sets	USD 4,700.00
BY1000 type	Pump set for 11630kW/3307Rt chillers	5 sets	USD5,200.00

Emphasize that the shipment should be effected before the end of June 2016 from Shanghai to Mexico with partial shipment and transshipment not allowed;

State the terms and the conditions of terms of payment, date of delivery for reference.

(2) 实施条件

项目	基本实施条件	备注
场地	每个商务英语实训室配置 40 个操作台面和座位，每个实训室照明通风良好。	必备
设备	每个商务英语实训室配有 1 台服务器、40—50 台计算机，并安装 Office 办公软件，配置局域网。	必备
测评专家	每 40 名考生配备 1 名考评员。考评员要求具备至少二年以上从事国际贸易工作经验或三年以上商务英语实践教学指导经历。	必备

(3) 考核时量

考核时间：90 分钟

(4) 评分标准

模块总分		评价内容	配分	考核点	备注
岗位核心技能模块一：外贸业务磋商（总分 100 分，占总评分的 50%）	职业素养与操作规范（10 分）	职业素养（6 分）	2 分	具备外贸从业人员基本素质，认真严谨、耐心细致、恪守信誉、实事求是、服从安排，听从指挥、举止文明，记 2 分。	在考试过程中不服从安排、举止不当者，记 0 分。
			2 分	具备外贸从业人员良好的谈判能力、外贸英语函电撰写能力和翻译能力，商务表达得体、规范到位，符合外贸行业对外贸业务、商务翻译、商务管理等相关岗位需求，记 2 分。	考试过程中出现与所述能力及素养不符，扣 1-2 分。
			2 分	具有良好的跨文化交流和商务礼仪等职业素养，在商务情境中具有敏锐的观察力和灵活的应变能力，记 2 分。	考试过程中出现与所述能力及素养不符，扣 1-2 分。
		操作规范（4 分）	2 分	具备使用办公设备和 Office 办公软件的能力，在考核过程中以及考核结束后，不私自更换电脑、不随意关闭或重启电脑，没征求监考老师同意不随意提前或推迟交卷，记 2 分。	若私自更换电脑、随意关闭或重启电脑，记 0 分。
			2 分	能严格遵守企业 6S 管理要求（整理、整顿、清扫、清洁、素养、安全），记 2 分。	若未遵守企业 6S 管理要求，记 0 分。
			15 分	英语表达通顺，语法、句法使用正确，记 15 分。	单词、句型错误每 3 处扣 1 分。
	作品（90 分）	外贸业务谈判（50 分）	10 分	应对得体，对话流转合理，记 10 分。	对话缺乏连贯性，每处酌情扣 1-2 分。

			10分	对话中能使用准确的与考核主题谈判的套语、术语记10分。	套语、术语搭配不合理，每处扣0.5分，搭配错误每处扣1分。
			15分	理解题目要求，信息点完整记15分。	信息点每缺失一处扣1分。
		外贸英语函电撰写(40分)	5分	函电格式完全正确，记5分。	日期、称呼语、结尾敬语、签名、排版每错2处扣1分。
			5分	字数达到要求，记5分。	每少10词扣1分。
			15分	语言表达通顺，语法、句型使用正确，记15分。	单词、语法每错3处扣1分。
			15分	理解题目要求，信息点完整，记15分。	信息点每缺失一处扣1分。

10. 试题编号：2-1-10 外贸业务磋商——包装与运输方式谈判

(1) 任务描述

任务1：商务谈判对话设计

内容：包装与运输方式谈判对话设计

要求：了解谈判双方背景，熟悉外贸业务流程和专业术语，灵活运用谈判策略，合理补充谈判对话，语言表达到位，交流畅通，环节紧凑。

考试资料

1. 出口方基本情况

Company	BROAD Air Quality Technology Group
Url	http://www.broad.com/
Office Address	Yuanda Town Yuanda 3 rd road, Changsha, Hunan, China
Zip code	410138
Phone	086-0731-84086688
Fax	086-0731-84552000

E-mail	css@broad.net
--------	---------------

2. 进口方基本情况

Company	Clima Tech Corporation
Url	http://www.clima-tech.com/tiki-index.php?page=HomePage
Office Address	5308 56th Commerce Park Boulevard, Tampa, U.S.A.
Phone	1- 323 -355 2121
Fax	1- 323 -355 2122
E-mail	sales@clima.com

3. 出口方信息

BROAD Air Quality Technology Group is an enterprise based on the vision of unique technologies and philosophy of preserving life. All BROAD products and services have essentially optimized human life and the environment of the earth. BROAD Air Conditioning Equipment Co. Ltd. supplies no-electric central air conditioning powered by natural gas and waste heat as well as packaged water distribution system.

BROAD Energy Utilization Co. Ltd. provides energy management contract service, district cooling-heating-power system (CHP) investment, building and operation.

BROAD Sustainable Building Technology Co. Ltd. provides factory-made sustainable building with level 9 earthquake resistances, with 6 times material less, 5time energy efficient, and 20 times air purification.

BROAD Air Quality Technology Group headquartered in Changsha, China, has already exported products to more than 70 countries.

Company Development Path

On June 5, 1988, using USD 3,000 the company was registered in Chenzhou, Hunan to develop heating equipment.

In 1992, the company relocated to Changsha to start producing large scale non-electric central air conditioning chillers and equipment.

In 1998 the company's non-electric air conditioners entered into the international market.

In 1999 the company began producing packaged central air conditioning systems.

In 2005 the company began producing air quality products, which are now sold in more than 60 countries around the world.

Products

The complete set of Central Air Conditioning Equipment (Including hot water, to automate a building)

Services

After Sales Service, Trusteeship Service, EMC (Engineering Design Consulting)

Value

Healthy, Energy Efficient, Cost Saving

Comments from Premier Wen Jiabao

“BROAD non-electric air conditioning is the Circular Economy.”

BROAD is not a common company which has made a special contribution to the country.

抽考试题

Section I 外贸业务谈判 (50 分)

Directions: You are required to complete a negotiation based on the following situation with at least 80 words.

Situation: You (David House), Purchasing Manager of Clima Tech Corporation visit Zhang Hua, Manager of Sales & Marketing Department of BROAD Air Quality Technology Group. You are talking about shipment for there's no direct shipment to the destination. The exporter suggests transshipment.

You are required to finish the following tasks:

A: You (the importer) B: Zhang Hua (the exporter)

A: _____

(Ask the availability of direct shipment.)

B: I'm sorry we can't do that, because all the shipping space till the end of November has been booked up.

A: _____

(Suggest contacting other shipping companies.)

B: We've done it, but to our disappointment, there's no direct ship from here to your port in these two months.

A: _____

(Enquire about the reason (two vessels sailing to the port of destination each month).)

B: There is a great demand at present and the bad climate prevents some direct routes.

A: _____

(Suggest adapting tramps.)

B: Yes, I can, but I'm not sure whether there would be enough tonnage to make a full cargo, even if a tramp could be obtained.

A: _____

(Expect to deliver the goods right away in other ways.)

B: Yes. If you could consider transshipment, we can have the goods transshipped at Hong Kong.

A: _____

(Express your worry on transshipment; (risks of pilferage and damage).)

B: That's true, but I still suggest you consider the transshipment. We'll have the goods covered under Risk of Breakage and TPND.

A: _____
(Wonder if the goods will arrive on time.)

B: We cannot assure you, but we will try our best.

A: _____
(State that you'll fax home and tell B the decision tomorrow.)

B: OK.

任务 2: 外贸英语函电撰写 (40 分)

内容: 包装与运输谈判函电撰写

要求: 理解命题要求, 确定函电性质; 函电格式正确, 字数达标; 表达流畅, 文字通顺, 逻辑合理。

Section II 外贸英语函电撰写

Directions: You are required to write a letter based on the following situation with at least 100 words. (Note: Your letter should adopt the modified-block style.)

Situation: As a sales representative of BROAD Air Quality Technology Group, you are going to write to a client from Clima tech Corporation to inform him about the transshipment of goods. (For more information about the two parties, please refer to the background information given above.)

The following aspects should be included in the letter:

Indicate the inside addresses of the sender, the receiver, the date, the complimentary close and the signature;

Inform the importer Air Condition Indoor Units would be delivered by transshipment;

Emphasize that there are six sailings monthly from Shanghai to USA;

Recommend Far East Marine Transport Co. to deliver the goods who has two sailings on the 10 and 20 respectively per month, from Shanghai to USA, shipping space will be booked through their agency in Wuhan;

Enclose a document to show the rate of the freight for the shipment;

Put forward your request that sight L/C must reach you before the shipment month if the importer wants the goods to be transshipped at Shanghai because you need to book shipping space with Wuhan agent;

Ask the importer when they want you to arrange the shipment.

(2) 实施条件

项目	基本实施条件	备注
场地	每个商务英语实训室配置 40 个操作台面和座位, 每个实训室照明通风良好。	必备

设备	每个商务英语实训室配有 1 台服务器、40—50 台计算机，并安装 Office 办公软件，配置局域网。	必备
测评专家	每 40 名考生配备 1 名考评员。考评员要求具备至少二年以上从事国际贸易工作经验或三年以上商务英语实践教学指导经历。	必备

(3) 考核时量

考核时间：90 分钟

(4) 评分标准

模块总分		评价内容	配分	考核点	备注
岗位核心技能模块一：外贸业务磋商（总分 100 分，占总评分的 50%）	职业素养与操作规范（10 分）	职业素养（6 分）	2 分	具备外贸从业人员基本素质，认真严谨、耐心细致、恪守信誉、实事求是、服从安排，听从指挥、举止文明，记 2 分。	在考试过程中不服从安排、举止不当者，记 0 分。
			2 分	具备外贸从业人员良好的谈判能力、外贸英语函电撰写能力和翻译能力，商务表达得体、规范到位，符合外贸行业对外贸业务、商务翻译、商务管理等相关岗位需求，记 2 分。	考试过程中出现与上述能力及素养不符，扣 1-2 分。
			2 分	具有良好的跨文化交流和商务礼仪等职业素养，在商务情境中具有敏锐的观察力和灵活的应变能力，记 2 分。	考试过程中出现与上述能力及素养不符，扣 1-2 分。
		操作规范（4 分）	2 分	具备使用办公设备和 Office 办公软件的能力，在考核过程中以及考核结束后，不私自更换电脑、不随意关闭或重启电脑，没征求监考老师同意不随意提前或推迟交卷，记 2 分。	若私自更换电脑、随意关闭或重启电脑，记 0 分。
			2 分	能严格遵守企业 6S 管理要求（整理、整顿、清扫、清洁、素养、安全），记 2 分。	若未遵守企业 6S 管理要求，记 0 分。
			15 分	英语表达通顺，语法、句法使用正确，记 15 分。	单词、句型错误每 3 处扣 1 分。
	作品（90 分）	外贸业务谈判（50 分）	10 分	应对得体，对话流转合理，记 10 分。	对话缺乏连贯性，每处酌情扣 1-2 分。
			10 分	对话中能使用准确的与考核主题谈判的套语、术语记 10 分。	套语、术语搭配不合理，每处扣 0.5 分，搭配错误每处扣 1 分。

		15分	理解题目要求，信息点完整记15分。	信息点每缺失一处扣1分。
	外贸英语函电撰写（40分）	5分	函电格式完全正确，记5分。	日期、称呼语、结尾敬语、签名、排版每错2处扣1分。
		5分	字数达到要求，记5分。	每少10词扣1分。
		15分	语言表达通顺，语法、句型使用正确，记15分。	单词、语法每错3处扣1分。
		15分	理解题目要求，信息点完整，记15分。	信息点每缺失一处扣1分。

11. 试题编号：2-1-11 外贸业务磋商——保险条款谈判

(1) 任务描述

任务1：商务谈判对话设计

内容：保险条款谈判对话设计

要求：了解谈判双方背景，熟悉外贸业务流程和专业术语，灵活运用谈判策略，合理补充谈判对话，语言表达到位，交流畅通，环节紧凑。

考试资料

1. 出口方基本情况

Company	BROAD Air Quality Technology Group
Url	http://www.broad.com/
Office Address	Yuanda Town Yuanda 3 rd road, Changsha, Hunan, China
Zip code	410138
Phone	086-0731-84086688
Fax	086-0731-84552000
E-mail	css@broad.net

2. 进口方基本情况

Company	Galaxy Refrigeration Private Limited Co.
Url	http://www.galaxyintl.com/
Office Address	No. D-8, Shanti Kunj, Near Church, Vasant Kunj New Delhi, India
Phone	+(91)-(11)-26130435
Fax	+(91)-(11)-26130436
E-mail	chanderkumar@hotmail.com

3. 出口方信息

BROAD Air Quality Technology Group is an enterprise based on the vision of unique technologies and philosophy of preserving life. All BROAD products and services have essentially optimized human life and the environment of the earth. BROAD Air Conditioning Equipment Co. Ltd. supplies no-electric central air conditioning powered by natural gas and waste heat as well as packaged water distribution system.

BROAD Energy Utilization Co. Ltd. provides energy management contract service, district cooling-heating-power system (CHP) investment, building and operation.

BROAD Sustainable Building Technology Co. Ltd. provides factory-made sustainable building with level 9 earthquake resistances, with 6 times material less, 5time energy efficient, and 20 times air purification.

BROAD Air Quality Technology Group headquartered in Changsha, China, has already exported products to more than 70 countries.

Company Development Path

On June 5, 1988, using USD 3,000 the company was registered in Chenzhou, Hunan to develop heating equipment.

In 1992, the company relocated to Changsha to start producing large scale non-electric central air conditioning chillers and equipment.

In 1998 the company's non-electric air conditioners entered into the international market.

In 1999 the company began producing packaged central air conditioning systems.

In 2005 the company began producing air quality products, which are now sold in more than 60 countries around the world.

Products

The complete set of Central Air Conditioning Equipment (Including hot water, to automate a building)

Services

After Sales Service, Trusteeship Service, EMC (Engineering Design Consulting)

Value

Healthy, Energy Efficient, Cost Saving

Comments from Premier Wen Jiabao

“BROAD non-electric air conditioning is the Circular Economy.”

BROAD is not a common company which has made a special contribution to the country.

抽考试题

Section I 外贸业务谈判 (50 分)

Directions: You are required to complete a negotiation based on the following situation with at least 80 words.

Situation: David Bush (the importer), Purchasing Manager of Galaxy Refrigeration Private Limited visits you (Liu Dongmei), trade representative of BROAD Air Quality Technology Group. You are discussing the insurance about WPA, the Risk of Breakage, and so on.

You are required to finish the following tasks:

A: David Bush (the importer) B: You (the exporter)

A: Good morning, Mr. Liu.

B: _____
(Extend greetings and offer help.)

A: Last time we discussed the terms of payment. Shall we talk about the terms of insurance today?

B: _____
(Show your willingness and ask if there are questions.)

A: Yes. I'd like to know what kind of insurance coverage you have in mind for the goods we ordered.

B: _____
(Consider WPA (basing on CIF).)

A: Could you cover the Risk of Breakage for us?

B: _____
(Give a positive answer, but refuse to bear extra premium.)

A: I see. By the way, in the event of loss of or damage to my goods, what is the procedure for filing a claim?

B: _____
(State the procedure for claim (Provide a survey report and claim after the arrival of the consignment).)

A: How long is the availability period to claim?

B: _____
(State the period for the claim (within 60 days after the arrival of the goods).)

A: That's understood. One more thing here, we'd like to have the goods insured for 130% of the invoice value. Can that be arranged?

B: _____
(Inform your usual practice for insurance value (110%) and can not bear extra premium.)

A: You can rest assured that we'll pay for the extra premium above 110% of the invoice value.

B: _____
(Express your willingness of cooperation.)

A: I hope so.

任务 2: 外贸英语函电撰写 (40 分)

内容: 保险条款谈判函电撰写

要求: 理解命题要求, 确定函电性质; 函电格式正确, 字数达标; 表达流畅, 文字通顺, 逻辑合理。

Section II 外贸英语函电撰写

Directions: You are required to write a letter based on the following situation with at least 100 words. (Note: Your letter should adopt the modified-block style.)

Situation: As a sales representative of BROAD Air Quality Technology Group, you are going to write to a client of Galaxy Refrigeration Private Limited Co. to introduce the insurance terms for X Vacuum Boiler. **(For more information about the two parties, please refer to the background information given above.)**

The following aspects should be included in the letter:

Indicate the inside addresses of the sender, the receiver, the date, the complimentary close and the signature;

Indicate the L/C No., value and issuing bank;

Show regret for the buyer's request for covering TPND and SRCC in addition to FPA and War Risk;

Emphasize that the additional insurance terms were not agreed upon by both parties; State the usual practice of the seller for the nature of the contracted goods and explain the reason;

Agree to cover the excessive risks at the buyer's cost;

Suggest amending the L/C to cover the extra premium

(2) 实施条件

项目	基本实施条件	备注
场地	每个商务英语实训室配置 40 个操作台面和座位, 每个实训室照明通风良好。	必备
设备	每个商务英语实训室配有 1 台服务器、40—50 台计算机, 并安装 Office 办公软件, 配置局域网。	必备

测评专家	每 40 名考生配备 1 名考评员。考评员要求具备至少二年以上从事国际贸易工作经验或三年以上商务英语实践教学指导经历。	必备
------	---	----

(3) 考核时量

考核时间：90 分钟

(4) 评分标准

模块总分		评价内容	配分	考核点	备注
岗位核心技能模块一：外贸业务磋商（总分 100 分，占总评分的 50%）	职业素养与操作规范（10 分）	职业素养（6 分）	2 分	具备外贸从业人员基本素质，认真严谨、耐心细致、恪守信誉、实事求是、服从安排，听从指挥、举止文明，记 2 分。	在考试过程中不服从安排、举止不当者，记 0 分。
			2 分	具备外贸从业人员良好的谈判能力、外贸英语函电撰写能力和翻译能力，商务表达得体、规范到位，符合外贸行业对外贸业务、商务翻译、商务管理等相关岗位需求，记 2 分。	考试过程中出现与上述能力及素养不符，扣 1-2 分。
			2 分	具有良好的跨文化交流和商务礼仪等职业素养，在商务情境中具有敏锐的观察力和灵活的应变能力，记 2 分。	考试过程中出现与上述能力及素养不符，扣 1-2 分。
		操作规范（4 分）	2 分	具备使用办公设备和 Office 办公软件的能力，在考核过程中以及考核结束后，不私自更换电脑、不随意关闭或重启电脑，没征求监考老师同意不随意提前或推迟交卷，记 2 分。	若私自更换电脑、随意关闭或重启电脑，记 0 分。
			2 分	能严格遵守企业 6S 管理要求（整理、整顿、清扫、清洁、素养、安全），记 2 分。	若未遵守企业 6S 管理要求，记 0 分。
			15 分	英语表达通顺，语法、句法使用正确，记 15 分。	单词、句型错误每 3 处扣 1 分。
	作品（90 分）	外贸业务谈判（50 分）	10 分	应对得体，对话流转合理，记 10 分。	对话缺乏连贯性，每处酌情扣 1-2 分。
			10 分	对话中能使用准确的与考核主题谈判的套语、术语记 10 分。	套语、术语搭配不合理，每处扣 0.5 分，搭配错误每处扣 1 分。
			15 分	理解题目要求，信息点完整记 15 分。	信息点每缺失一处扣 1 分。

	外贸英语函电撰写(40分)	5分	函电格式完全正确,记5分。	日期、称呼语、结尾敬语、签名、排版每错2处扣1分。
		5分	字数达到要求,记5分。	每少10词扣1分。
		15分	语言表达通顺,语法、句型使用正确,记15分。	单词、语法每错3处扣1分。
		15分	理解题目要求,信息点完整,记15分。	信息点每缺失一处扣1分。

12. 试题编号: 2-1-12 外贸业务磋商——价格谈判

(1) 任务描述

任务1: 商务谈判对话设计

内容: 价格谈判对话设计

要求: 了解谈判双方背景,熟悉外贸业务流程和专业术语,灵活运用谈判策略,合理补全谈判对话,语言表达到位,交流畅通,环节紧凑。

考试资料

1. 出口方基本情况

Company	Hunan Haili Chemical Industry Co. Ltd.
Url	http://www.hnhlc.com
Office Address	NO.251, 2nd Section, Furong(M) Road, Changsha, Hunan, China
Zip code	410007
Phone	86-731-85357829
Fax	86-731-85357977
E-mail	sh600731@sina.com

2. 进口方基本情况

Company	Devidayal (Sales) Limited
Url	http://www.devidayalagro.com/
Office Address	1 st Floor Devidayal Estate, Reay Road, Mumbai 400 010, India
Phone	+91-22-23714913/ 23734871
Fax	+91-22-23742708
E-mail	bombay@devidayalagro.com

3. 出口方信息

Hunan Haili Chemical Industry Co., Ltd. (Hunan Haili) is one of the hi-tech listing enterprises in China, which is mainly formed by Hunan Research Institute of Chemical Industry. Hunan Haili mainly devotes itself to development, production and trade of pesticides and fine chemicals, transportation of dangerous chemicals, installation of chemical facilities. Hunan Haili is fully reinforced at R & D and production of pesticides, which becomes State Pesticide Development & Engineering Technology Research Center and State Carbamate Pesticide Industry Pilot Base.

Hunan Haili has built up the largest production facilities in Asia with annual capacity over 10,000 tons for Carbamate pesticides such as Carbofuran, BPMC, Carbaryl, Carbosulfan, Propoxur, Isoprocarb, Methomyl, MTMC, etc. Hunan Haili has also built up the largest production facilities in Asia with annual capacity over 10,000 tons for alkylation production, such as Benzofuranol, OSBP, o-isopropyl phenol and o-isopropoxy phenyl, etc. Hunan Haili has built up facilities with annual capacity over 10,000 tons for organ phosphorus pesticides like Dimethoate and pirimiphos methyl. Depending on the phosgene production facilities with annual capacity of 10,000MT and 5,000MT, Hunan Haili has developed isocyanates, chloroformates, carbonates, urea phosgene derivatives and also undertaken chemicals processing.

Carbamate pesticides, Dimethoate pesticides and alkylphenol intermediates with Haili Brand are the famous products in Hunan Province. Haili Brand is the famous brand in Hunan Province. Since listed in 1996, Hunan Haili has achieved sound and rapid progress, which has held and annexed five domestic enterprises. Hunan Haili has been ISO9001:2000 and ISO14001:2004 certified and passed certification of GB/T28001-2001 in China.

Main Products:

- Insecticides
- Fungicides
- Phosgene Derivatives
- Intermediates
- Amino-protecting agents
- Special Chemicals
- Formulation Productions

- Seed coating agent

抽考试题

Section I 外贸业务谈判 (50 分)

Directions: You are required to complete a negotiation based on the following situation with at least 80 words.

Situation: You (Edward Green), Purchasing Manager of Devidayal (Sales) Limited, along with Don Smith, your assistant and David Brown, an accountant, visit Huang Songjun (the exporter), Manager of Sales & Marketing Department of Hunan Haili Chemical Industry Co. Ltd. You are holding a negotiation on the price.

You are required to finish the following tasks:

A: You (the importer)

B: Huang Songjun(the exporter)

- A: _____
(Introduce your colleagues.)
- B: How do you do, Mr. Smith. How do you do? Mr. Brown.
- A: _____
(Show interest in the monosultap of HLC and ask for more details.)
- B: I'd be happy to answer any questions you may have.
- A: _____
(Inquire about the unit price.)
- B: Sure, We usually offer a unit price of USD80 per bag. If you can have larger size, you can have a discount of 2%.
- A: _____
(Ask for 5% discount.)
- B: I'm sorry, but that is a little too high. Our standard policy on discounts of over 4% is payment of irrevocable L/C at sight.
- A: _____
(Suggest D/P and explain the reason.)
- B: I am sorry we can't make it.
- A: _____
(Ask about the commission.)
- B: Usually, we give a commission of 2% to our agents.
- A: _____
(Suggest a commission of 4%.)
- B: If you sell US\$ 2 million annually, we can allow 3% commission.
- A: _____
(Suggest discussing the details tomorrow.)
- B: No problem.

任务 2: 外贸英语函电撰写 (40 分)

内容: 价格谈判函电撰写

要求: 理解命题要求, 确定函电性质; 函电格式正确, 字数达标;

表达流畅，文字通顺，逻辑合理。

Section II 外贸英语函电撰写

Directions: You are required to write a letter based on the following situation with at least 100 words. (Note: Your letter should adopt the modified-block style.)

Situation: As the Purchasing Manager of Devidayal (Sales) Limited, you are going to write to the Sales Manager of Hunan Haili Chemical Industry Co. Ltd., to ask for 10% price reduction of its insecticide---Monosultap after trial use of the samples sent on March 8. (For more information about the two parties, please refer to the background information given above.)

The following aspects should be included in the letter:

Indicate the inside addresses of the sender, the receiver, the date, the complimentary close and the signature;

State that customers are satisfied with the insecticide but are still hesitating; Introduce the market situations—various providers are promoting insecticides with strong efficacy and reasonable prices;

Provide information that the prices of some brands of insecticides are 10% less; Indicate that price advantage is still necessary in occupying the market.

(2) 实施条件

项目	基本实施条件	备注
场地	每个商务英语实训室配置 40 个操作台面和座位，每个实训室照明通风良好。	必备
设备	每个商务英语实训室配有 1 台服务器、40—50 台计算机，并安装 Office 办公软件，配置局域网。	必备
测评专家	每 40 名考生配备 1 名考评员。考评员要求具备至少二年以上从事国际贸易工作经验或三年以上商务英语实践教学指导经历。	必备

(3) 考核时量

考核时间：90 分钟

(4) 评分标准

模块总分	评价内容	配分	考核点	备注
岗位核心	职业素养	2 分	具备外贸从业人员基本素质，认真严谨、耐心细致、恪守信誉、实事求是、服从安	在考试过程中不服从安排、举止不得

技能模块一：外贸业务磋商（总分100分，占总评分的50%）	与操作规范（10分）	（6分）		排，听从指挥、举止文明，记2分。	当者，记0分。		
		2分		具备外贸从业人员良好的谈判能力、外贸英语函电撰写能力和翻译能力，商务表达得体、规范到位，符合外贸行业对外贸业务、商务翻译、商务管理等相关岗位需求，记2分。	考试过程中出现与上述能力及素养不符，扣1-2分。		
		2分		具有良好的跨文化交流和商务礼仪等职业素养，在商务情境中具有敏锐的观察力和灵活的应变能力，记2分。	考试过程中出现与上述能力及素养不符，扣1-2分。		
		操作规范（4分）		2分	具备使用办公设备和 Office 办公软件的能力，在考核过程中以及考核结束后，不私自更换电脑、不随意关闭或重启电脑，没征求监考老师同意不随意提前或推迟交卷，记2分。	若私自更换电脑、随意关闭或重启电脑，记0分。	
			2分	能严格遵守企业 6S 管理要求（整理、整顿、清扫、清洁、素养、安全），记2分。	若未遵守企业 6S 管理要求，记0分。		
	作品（90分）		外贸业务谈判（50分）	15分	英语表达通顺，语法、句法使用正确，记15分。	单词、句型错误每3处扣1分。	
				10分	应对得体，对话流转合理，记10分。	对话缺乏连贯性，每处酌情扣1-2分。	
				10分	对话中能使用准确的与考核主题谈判的套语、术语记10分。	套语、术语搭配不合理，每处扣0.5分，搭配错误每处扣1分。	
				15分	理解题目要求，信息点完整记15分。	信息点每缺失一处扣1分。	
			外贸英语函电撰写（40分）		5分	函电格式完全正确，记5分。	日期、称呼语、结尾敬语、签名、排版每错2处扣1分。
					5分	字数达到要求，记5分。	每少10词扣1分。
					15分	语言表达通顺，语法、句型使用正确，记15分。	单词、语法每错3处扣1分。
			15分	理解题目要求，信息点完整，记15分。	信息点每缺失一处扣1分。		

13. 试题编号：2-1-13 外贸业务磋商——投诉与索赔谈判

（1）任务描述

任务1：商务谈判对话设计

内容：投诉与索赔谈判对话设计

要求：了解谈判双方背景，熟悉外贸业务流程和专业术语，灵活运用谈判策略，合理补全谈判对话，语言表达到位，交流畅通，环节紧凑。

考试资料

1. 出口方基本情况

Company	Hunan Haili Chemical Industry Co. Ltd.
Url	http://www.hnhlc.com
Office Address	NO.251, 2nd Section, Furong(M) Road, Changsha, Hunan, China
Zip code	410007
Phone	86-731-85357829
Fax	86-731-85357977
E-mail	sh600731@sina.com

2. 进口方基本情况

Company	MainPlus Chemicals Ltd. (U.K.)
Url	http://www.mainpluschem.com/
Office Address	145-157 St. John Street, London, EC1V 4PY, U.K.
Phone	+44 20 8816 7120
Fax	+44 70 0602 6085

3. 出口方信息

Hunan Haili Chemical Industry Co., Ltd. (Hunan Haili) is one of the hi-tech listing enterprises in China, which is mainly formed by Hunan Research Institute of Chemical Industry. Hunan Haili mainly devotes itself to development, production and trade of pesticides and fine chemicals, transportation of dangerous chemicals, installation of chemical facilities. Hunan Haili is fully reinforced at R & D and

production of pesticides, which becomes State Pesticide Development & Engineering Technology Research Center and State Carbamate Pesticide Industry Pilot Base.

Hunan Haili has built up the largest production facilities in Asia with annual capacity over 10,000 tons for Carbamate pesticides such as Carbofuran, BPMC, Carbaryl, Carbosulfan, Propoxur, Isoprocarb, Methomyl, MTMC, etc. Hunan Haili has also built up the largest production facilities in Asia with annual capacity over 10,000 tons for alkylation production, such as Benzofuranol, OSBP, o-isopropyl phenol and o-isopropoxy phenyl, etc. Hunan Haili has built up facilities with annual capacity over 10,000 tons for organ phosphorus pesticides like Dimethoate and pirimiphos methyl. Depending on the phosgene production facilities with annual capacity of 10,000MT and 5,000MT, Hunan Haili has developed isocyanates, chloroformates, carbonates, urea phosgene derivatives and also undertaken chemicals processing.

Carbamate pesticides, Dimethoate pesticides and alkylphenol intermediates with Haili Brand are the famous products in Hunan Province. Haili Brand is the famous brand in Hunan Province. Since listed in 1996, Hunan Haili has achieved sound and rapid progress, which has held and annexed five domestic enterprises. Hunan Haili has been ISO9001:2000 and ISO14001:2004 certified and passed certification of GB/T28001-2001 in China.

Main Products:

- Insecticides
- Fungicides
- Phosgene Derivatives
- Intermediates
- Amino-protecting agents
- Special Chemicals
- Formulation Productions
- Seed coating agent

抽考试题

Section I 外贸业务谈判 (50分)

Directions: You are required to complete a negotiation based on the following situation with at least 80 words.

Situation: James Carter (the importer), Purchasing Manager of MainPlus Chemicals Ltd. (U.K.), is calling **you** (Huang Songjun), Manager of Sales & Marketing Department of Hunan Haili Chemical Industry Co. Ltd.. James lodged a claim with you on the wrong goods sent to them the day before by fax. Now James is inquiring about it.

You are required to finish the following tasks:

A: James Carter (the importer)

B: You (the exporter)

A: Good morning, Mr. Huang. This is James Carter speaking. We lodged a claim with you for the wrong shipment yesterday by fax. Have you received it yet?

B: _____

(Extend greetings and admit having received the fax.)

A: Have you found the problem yet?

B: _____

(Inform having investigated and clarified the fault (made by Shipping Department).)

A: Did they check the goods before shipment?

B: _____

(Admit the fault was due to the poor management.)

A: What annoys us most is that we think the case is made deliberately or intentionally.

B: _____

(Show deep regret and explain mistakes are inevitable sometimes.)

A: Since these errors on your part caused us to disappoint our important customers, I'm afraid you should compensate us by 5% of the total amount of the contract.

B: _____

(Show apology and allow only a claim of 3%.)

A: It is natural that you should be responsible for all the losses resulting from the incorrect shipment.

B: _____

(Beg to send the goods back, and promise to cover all the cost.)

A: OK! As you know, we have been put into a very awkward situation on account of this wrong shipment. Please deliver our goods as soon as possible.

B: _____

(Promise to send the right shipment soon.)

A: OK. We will wait for your solution.

B: _____

(Show regret and promise to do better.)

任务 2: 外贸英语函电撰写 (40 分)

内容: 投诉与索赔谈判函电撰写

要求: 理解命题要求, 确定函电性质; 函电格式正确, 字数达标;

表达流畅, 文字通顺, 逻辑合理。

Section II 外贸英语函电撰写

Directions: You are required to write a letter based on the following situation with at least 100 words. (Note: Your letter should adopt the modified-block style.)

Situation: As the Marketing Manager of Hunan Haili Chemical Industry Co., Ltd., you are going to write to the Purchasing Manager from MainPlus Chemicals Ltd.(UK) to settle the claim lodged for your fungicide---Carbendzim after receiving the letter dated February 6, enclosed with a survey report. **(For more information about the two parties, please refer to the background information given above.)**

The following aspects should be included in the letter:

Indicate the inside addresses of the sender, the receiver, the date, the complimentary close and the signature;

Give the reason of the claim from the buyer—the efficacy of the fungicide is inferior to the sample;

Give the reason of refusing 10% price reduction—the advance sample prior to shipment did not receive any contrary voice from the buyer;

State the fact--the products shipped are of good quality and never receive any complaints from customers;

Propose a 5% discount owing to the consideration---longstanding relations and the goods are examined by a Public Surveyor.

(2) 实施条件

项目	基本实施条件	备注
场地	每个商务英语实训室配置 40 个操作台面和座位，每个实训室照明通风良好。	必备
设备	每个商务英语实训室配有 1 台服务器、40—50 台计算机，并安装 Office 办公软件，配置局域网。	必备
测评专家	每 40 名考生配备 1 名考评员。考评员要求具备至少二年以上从事国际贸易工作经验或三年以上商务英语实践教学指导经历。	必备

(3) 考核时量

考核时间：90 分钟

(4) 评分标准

模块总分	评价内容	配分	考核点	备注	
岗位核心技能模块一：外贸业务磋商（总分 100 分，占	职业素养与操作规范（10 分）	职业素养（6 分）	2 分	具备外贸从业人员基本素质，认真严谨、耐心细致、恪守信誉、实事求是、服从安排，听从指挥、举止文明，记 2 分。	在考试过程中不服从安排、举止不当者，记 0 分。
			2 分	具备外贸从业人员良好的谈判能力、外贸英语函电撰写能力和翻译能力，商务表达得体、规范到位，符合外贸行业对外贸业务、商务翻译、商务管理等相关岗位需求，记 2 分。	考试过程中出现与上述能力及素养不符，扣 1-2 分。
			2 分	具有良好的跨文化交流和商务礼仪等职业素养，在商务情境中具有敏锐的观察力和灵活的应变能力，记 2 分。	考试过程中出现与上述能力及素养不符，扣 1-2 分。

总评分的 50%)	操作规范 (4分)	2分	具备使用办公设备和 Office 办公软件的能力, 在考核过程中以及考核结束后, 不私自更换电脑、不随意关闭或重启电脑, 没征求监考老师同意不随意提前或推迟交卷, 记 2 分。	若私自更换电脑、随意关闭或重启电脑, 记 0 分。
		2分	能严格遵守企业 6S 管理要求(整理、整顿、清扫、清洁、素养、安全), 记 2 分。	若未遵守企业 6S 管理要求, 记 0 分。
	外贸业务谈判 (50分)	15分	英语表达通顺, 语法、句法使用正确, 记 15 分。	单词、句型错误每 3 处扣 1 分。
		10分	应对得体, 对话流转合理, 记 10 分。	对话缺乏连贯性, 每处酌情扣 1-2 分。
		10分	对话中能使用准确的与考核主题谈判的套语、术语记 10 分。	套语、术语搭配不合理, 每处扣 0.5 分, 搭配错误每处扣 1 分。
		15分	理解题目要求, 信息点完整记 15 分。	信息点每缺失一处扣 1 分。
	外贸英语函电撰写 (40分)	5分	函电格式完全正确, 记 5 分。	日期、称呼语、结尾敬语、签名、排版每错 2 处扣 1 分。
		5分	字数达到要求, 记 5 分。	每少 10 词扣 1 分。
		15分	语言表达通顺, 语法、句型使用正确, 记 15 分。	单词、语法每错 3 处扣 1 分。
		15分	理解题目要求, 信息点完整, 记 15 分。	信息点每缺失一处扣 1 分。
作品 (90分)				

14. 试题编号: 2-1-14 外贸业务磋商——建立贸易关系

(1) 任务描述

任务 1: 商务谈判对话设计

内容: 建立贸易关系对话设计

要求: 了解谈判双方背景, 熟悉外贸业务流程和专业术语, 灵活运用谈判策略, 合理补全谈判对话, 语言达到位, 交流畅通, 环节紧凑。

考试资料

1. 出口方基本情况

Company	Hunan Haili Chemical Industry Co. Ltd.
Url	http://www.hnhlc.com
Office Address	No.251, 2nd Section, Furong(M) Road, Changsha, Hunan, China
Zip code	410007
Phone	86-731-85357829
Fax:	86-731-85357977
E-mail	sh600731@sina.com

2. 进口方基本情况

Company	FMC Corporation
Url	http://www.fmc.com/
Office Address	1735 Market Street, Philadelphia, PA 19103 U.S.A.
Tollfree	1 800-323-7107
Phone	215-299-6000
Fax	215-299-5998

3. 出口方信息

Hunan Haili Chemical Industry Co., Ltd. (Hunan Haili) is one of the hi-tech listing enterprises in China, which is mainly formed by Hunan Research Institute of Chemical Industry. Hunan Haili mainly devotes itself to development, production and trade of pesticides and fine chemicals, transportation of dangerous chemicals, installation of chemical facilities. Hunan Haili is fully reinforced at R & D and production of pesticides, which becomes State Pesticide Development & Engineering Technology Research Center and State Carbamate Pesticide Industry Pilot Base.

Hunan Haili has built up the largest production facilities in Asia with annual capacity over 10000 tons for Carbamate pesticides such as Carbofuran, BPMC, Carbaryl, Carbosulfan, Propoxur, Isoprocarb, Methomyl, MTMC, etc. Hunan Haili

has also built up the largest production facilities in Asia with annual capacity over 10000 tons for alkylation production, such as Benzofuranol, OSBP, o-isopropyl phenol and o-isopropoxy phenyl, etc. Hunan Haili has built up facilities with annual capacity over 10000 tons for organophosphorus pesticides like Dimethoate and pirimiphos methyl. Depending on the phosgene production facilities with annual capacity of 10000MT and 5000MT, Hunan Haili has developed isocyanates, chloroformates, carbonates, urea phosgene derivatives and also undertaken chemicals processing.

Carbamate pesticides, Dimethoate pesticides and alkylphenol intermediates with Haili Brand are the famous products in Hunan Province. Haili Brand is the famous brand in Hunan Province. Since listed in 1996, Hunan Haili has achieved sound and rapid progress, which has held and annexed five domestic enterprises. Hunan Haili has been ISO9001:2000 and ISO14001:2004 certified and passed certification of GB/T28001-2001 in China.

Main Products:

- Insecticides
- Fungicides
- Phosgene Derivatives
- Intermediates
- Amino-protecting agents
- Special Chemicals
- Formulation Productions
- Seed coating agent

抽考试题

Section I 外贸业务谈判 (50 分)

Directions: You are required to complete a negotiation based on the following situation with at least 80 words.

Situation: Daniel Black (the importer), Purchasing Manager of FMC Corporation visits **you** (Huang Jianjun), Manager of Sales & Marketing Department of Hunan Haili Chemical Industry Co. Ltd (HLC). Mr. Black expresses his wishes to establish business relations with HLC.

You are required to finish the following tasks:

A: Daniel Black (the importer)

B: You (the exporter)

A: Good morning, Mr. Huang. I'm Daniel Black from FMC Corporation. This is my card.

B: _____

(Greet and exchange business card.)

A: We've come to know your name and address from the Commercial Counselor's Office of the Chinese Embassy in America. And we learned that HLC is a big corporation in chemical industry field in China. We are willing to enter into business relations with your firm.

B: _____

(Extend the same wish to establish business relations.)

A: Our Corporation is a diversified chemical company serving global agricultural, industrial and consumer markets. We have great interest in concluding a deal with your firm and it would be very helpful if you could introduce your products.

B: _____

(Show the product catalogue and price list.)

A: Thank you.

B: _____

(Emphasize your reasonable price.)

A: OK. Do you have quality inspection certificate ?

B: _____

(Indicate your high quality (national inspection certificate).)

A: What is your usual practice for terms of payment?

B: _____

(State your usual payment practice (L/C).)

A: I have a feeling that we can do a lot of trade in this line. Concerning our financial position, credit standing and trade reputation, you may refer to Citibank, our local Chamber of Commerce or related agencies.

B: _____

(Promise to trade on the basis of equality and mutual benefit.)

A: That sounds good. I'll send a fax home. As soon as I receive a definite answer, I'll make a specific inquiry.

B: _____

(Promise to make an offer soon..)

A: Thank you.

任务 2: 外贸英语函电撰写 (40 分)

内容: 建立贸易关系函电撰写

要求: 理解命题要求, 确定函电性质; 函电格式正确, 字数达标; 表达流畅, 文字通顺, 逻辑合理。

Section II 外贸英语函电撰写

Directions: You are required to write a letter based on the following situation with at least 100 words. (Note: Your letter should adopt the modified-block style.)

Situation: As a sales representative of Hunan Haili Chemical Industry Co. Ltd., you are going to write to a client from FMC Corporation, who was introduced by the Commercial Counselor's Office in U.S.A., with the hope of establishing business relations with him. **(For more information about the two parties, please refer to the background information given above.)**

The following aspects should be included in the letter:

Indicate the inside addresses of the sender, the receiver, the date, the

complimentary close and the signature;
 Specify the information channel;
 Extend your wish to establish business relations; Introduce your company information and main products;
 Provide commodity books and several samples for reference.

(2) 实施条件

项目	基本实施条件	备注
场地	每个商务英语实训室配置 40 个操作台面和座位，每个实训室照明通风良好。	必备
设备	每个商务英语实训室配有 1 台服务器、40—50 台计算机，并安装 Office 办公软件，配置局域网。	必备
测评专家	每 40 名考生配备 1 名考评员。考评员要求具备至少二年以上从事国际贸易工作经验或三年以上商务英语实践教学指导经历。	必备

(3) 考核时量

考核时间：90 分钟

(4) 评分标准

模块总分		评价内容	配分	考核点	备注
岗位核心技能模块一：外贸业务磋商（总分 100 分，占总评分的 50%）	职业素养与操作规范（10 分）	职业素养（6 分）	2 分	具备外贸从业人员基本素质，认真严谨、耐心细致、恪守信誉、实事求是、服从安排，听从指挥、举止文明，记 2 分。	在考试过程中不服从安排、举止不当者，记 0 分。
			2 分	具备外贸从业人员良好的谈判能力、外贸英语函电撰写能力和翻译能力，商务表达得体、规范到位，符合外贸行业对外贸业务、商务翻译、商务管理等相关岗位需求，记 2 分。	考试过程中出现与上述能力及素养不符，扣 1-2 分。
			2 分	具有良好的跨文化交流和商务礼仪等职业素养，在商务情境中具有敏锐的观察力和灵活的应变能力，记 2 分。	考试过程中出现与上述能力及素养不符，扣 1-2 分。
		操作规范（4 分）	2 分	具备使用办公设备和 Office 办公软件的能力，在考核过程中以及考核结束后，不私自更换电脑、不随意关闭或重启电脑，没征求监考老师同意不随意提前或推迟交卷，记 2 分。	若私自更换电脑、随意关闭或重启电脑，记 0 分。

			2分	能严格遵守企业 6S 管理要求（整理、整顿、清扫、清洁、素养、安全），记 2 分。	若未遵守企业 6S 管理要求，记 0 分。
作品 (90分)	外贸 业务 谈判 (50分)		15分	英语表达通顺，语法、句法使用正确，记 15 分。	单词、句型错误每 3 处扣 1 分。
			10分	应对得体，对话流转合理，记 10 分。	对话缺乏连贯性，每处酌情扣 1-2 分。
			10分	对话中能使用准确的与考核主题谈判的套语、术语记 10 分。	套语、术语搭配不合理，每处扣 0.5 分，搭配错误每处扣 1 分。
			15分	理解题目要求，信息点完整记 15 分。	信息点每缺失一处扣 1 分。
			5分	函电格式完全正确，记 5 分。	日期、称呼语、结尾敬语、签名、排版每错 2 处扣 1 分。
	外贸 英语 函电 撰写 (40分)		5分	字数达到要求，记 5 分。	每少 10 词扣 1 分。
			15分	语言表达通顺，语法、句型使用正确，记 15 分。	单词、语法每错 3 处扣 1 分。
			15分	理解题目要求，信息点完整，记 15 分。	信息点每缺失一处扣 1 分。

15. 试题编号：2-1-15 外贸业务磋商——价格谈判

(1) 任务描述

任务 1：商务谈判对话设计

内容：价格谈判对话设计

要求：了解谈判双方背景，熟悉外贸业务流程和专业术语，灵活运用谈判策略，合理补充谈判对话，语言表达到位，交流畅通，环节紧凑。

考试资料

1. 出口方基本情况

Company	Sany Group
---------	------------

Url	http://www.sanygroup.com/group/en-us/
Office Address	Sany Industry Town, Economic and Technological Development Zone, Changsha, Hunan, China
Phone	0086-21-20271802
E-mail	crd@sany.com.cn

2. 进口方基本情况

Company	Merco Trading Co.
Url	http://www.merco.com.au/products.php
Office Address	9-11 Harvard Way, Canning Vale6155, Australia Western Australia,
Phone	+46 (0)40 42106025
Mobile:	+46 (0)70642106126
E-mail	info@mercotrading.s24e

3. 出口方信息

Sany Group began in 1989 as a small welding material factory. Its founders are Liang Wengen, Tang Xiuguo, Mao Zhongwu and Yuan Jinhua. Now it has grown into a global corporation with five industrial parks in China, four R&D and manufacturing bases in America, Germany, India and Brazil, and 24 sales companies around the world. Currently, Sany Group employs over 60,000 people in more than 120 countries.

At Sany Group, we believe that developing and manufacturing of quality, industry-leading products is always a top priority. Each year, Sany Group re-invests 5-7% of its sales revenue into the R&D, making it possible to expand its product lines to concrete, road, port, hoisting, pile driving, excavating machineries and wind energy products. Now as one of the most successful enterprises in China, Sany Group is also the world's largest concrete machinery manufacturer and ranks 6th among the top 50 global construction machinery manufacturers.

Besides constantly improving the quality of our products, Sany Group is also committed to providing customers with all-round and efficient services. 15 logistics centers and spare parts warehouses have been set up with logistics and service systems all over the world.

抽考试题

Section I 外贸业务谈判 (50分)

Directions: You are required to complete a negotiation based on the following situation with at least 80 words.

Situation: You (Bob Hill), Purchasing Manager of Merco Trading Co., are visiting Sany Group. You are inquiring about the commodity of pipe for engine. Lin Xiong (the exporter), Marketing Manager of Sany Group, is negotiating with you.

You are required to finish the following tasks:

A: Lin Xiong (the exporter)

B: You (the importer)

A: Good morning, Mr. Hill. Glad to meet you.

B: _____

(Extend greetings and state your purpose (discuss the details).)

A: Welcome. What can I do for you?

B: _____

(Ask for the price list and catalogues of pipe for engine.)

A: Here you are.

B: _____

(Show interest in R130(UP PIPE), R200(DOWN PIPE) and R220 (UP PIPE), but point out that the prices are too high.)

A: Our prices are the most reasonable. Heavy enquiries witness the quality of our products.

B: _____

(Cut down the price by 8%.)

A: 8%? I'm afraid you are asking too much. But for friendship's sake, we may exceptionally consider reducing the price by 5%. This is the highest reduction we can afford.

B: _____

(Suggest D/P.)

A: Payment by L/C is our usual practice of doing business with all customers for such commodities. I'm sorry we can't accept D/P terms.

B: _____

(Request for earlier shipment.)

A: Yes, shipment is to be made in April, not allowing partial shipment.

B: _____

(Suggest being packed in cardboard boxes.)

A: OK. We can do that.

B: _____

(Show your gratitude and hope for future business.)

A: I hope so.

任务 2: 外贸英语函电撰写 (40 分)

内容: 价格谈判函电撰写

要求: 理解命题要求, 确定函电性质; 函电格式正确, 字数达标;

表达流畅, 文字通顺, 逻辑合理。

Section II 外贸英语函电撰写

Directions: You are required to write a letter based on the following situation with at least 100 words. (Note: Your letter should adopt the modified-block style.)

Situation: As the Purchasing Manager of Merco Trading Co., you are going to write to the Marketing Manager from Sany Group, the leading global company in construction machinery, to make specific inquiries. **(For more information about the two parties, please refer to the background information given above.)**

The following aspects should be included in the letter:

Indicate the inside addresses of the sender, the receiver, the date, the complimentary close and the signature;

Show interest in their pipe for engine for mainly three specifications---R130 (Up Pipe), R200 (Down Pipe), R220 (Up Pipe);

Ask for sample books and all necessary information about the products by airmail;

Ask the exporter to quote the lowest price CIF New York, stating the earliest date of shipment;

State your terms of payment—irrevocable L/C in favor of the seller; Promise to place large orders if prices are found competitive.

(2) 实施条件

项目	基本实施条件	备注
场地	每个商务英语实训室配置 40 个操作台面和座位，每个实训室照明通风良好。	必备
设备	每个商务英语实训室配有 1 台服务器、40—50 台计算机，并安装 Office 办公软件，配置局域网。	必备
测评专家	每 40 名考生配备 1 名考评员。考评员要求具备至少二年以上从事国际贸易工作经验或三年以上商务英语实践教学指导经历。	必备

(3) 考核时量

考核时间：90 分钟

(4) 评分标准

模块总分	评价内容	配分	考核点	备注
岗位核心	职业素养	2 分	具备外贸从业人员基本素质，认真严谨、耐心细致、恪守信誉、实事求是、服从安	在考试过程中不服从安排、举止不得

技能模块一：外贸业务磋商（总分100分，占总评分的50%）	与操作规范（10分）	（6分）		排，听从指挥、举止文明，记2分。	当者，记0分。
		2分		具备外贸从业人员良好的谈判能力、外贸英语函电撰写能力和翻译能力，商务表达得体、规范到位，符合外贸行业对外贸业务、商务翻译、商务管理等相关岗位需求，记2分。	考试过程中出现与上述能力及素养不符，扣1-2分。
		2分		具有良好的跨文化交流和商务礼仪等职业素养，在商务情境中具有敏锐的观察力和灵活的应变能力，记2分。	考试过程中出现与上述能力及素养不符，扣1-2分。
		操作规范（4分）	2分	具备使用办公设备和 Office 办公软件的能力，在考核过程中以及考核结束后，不私自更换电脑、不随意关闭或重启电脑，没征求监考老师同意不随意提前或推迟交卷，记2分。	若私自更换电脑、随意关闭或重启电脑，记0分。
			2分	能严格遵守企业 6S 管理要求（整理、整顿、清扫、清洁、素养、安全），记2分。	若未遵守企业 6S 管理要求，记0分。
	作品（90分）	外贸业务谈判（50分）	15分	英语表达通顺，语法、句法使用正确，记15分。	单词、句型错误每3处扣1分。
			10分	应对得体，对话流转合理，记10分。	对话缺乏连贯性，每处酌情扣1-2分。
			10分	对话中能使用准确的与考核主题谈判的套语、术语记10分。	套语、术语搭配不合理，每处扣0.5分，搭配错误每处扣1分。
			15分	理解题目要求，信息点完整记15分。	信息点每缺失一处扣1分。
		外贸英语函电撰写（40分）	5分	函电格式完全正确，记5分。	日期、称呼语、结尾敬语、签名、排版每错2处扣1分。
			5分	字数达到要求，记5分。	每少10词扣1分。
			15分	语言表达通顺，语法、句型使用正确，记15分。	单词、语法每错3处扣1分。
			15分	理解题目要求，信息点完整，记15分。	信息点每缺失一处扣1分。

16. 试题编号：2-1-16 外贸业务磋商——包装与运输方式谈判

（1）任务描述

任务1：商务谈判对话设计

内容：包装与运输方式谈判对话设计

要求：了解谈判双方背景，熟悉外贸业务流程和专业术语，灵活运用谈判策略，合理补全谈判对话，语言表达到位，交流畅通，环节紧凑。

考试资料

1. 出口方基本情况

Company	Sany Group
Url	http://www.sanygroup.com/group/en-us/
Office Address	Sany Industry Town, Economic and Technological Development Zone, Changsha, Hunan, China
Phone	0086-21-20271802
E-mail	crd@sany.com.cn

2. 进口方基本情况

Company	MALI Group
Url	http://mali-group.visionline.ch/en/home/
Office Address	Landstrase 175 5430 wettngen Switzerland
Phone	+41 56 444 22 33
Fax:	+41 56 444 22 30
E-mail	info@Mali-group.com

3. 出口方信息

Sany Group began in 1989 as a small welding material factory. Its founders are Liang Wengen, Tang Xiuguo, Mao Zhongwu and Yuan Jinhua. Now it has grown into a global corporation with five industrial parks in China, four R&D and manufacturing bases in America, Germany, India and Brazil, and 24 sales companies around the world. Currently, Sany Group employs over 60,000 people in more than 120 countries.

At Sany Group, we believe that developing and manufacturing of quality, industry-leading products is always a top priority. Each year, Sany Group re-invests 5-7% of its sales revenue into the R&D, making it possible to expand its product lines

to concrete, road, port, hoisting, pile driving, excavating machineries and wind energy products. Now as one of the most successful enterprises in China, Sany Group is also the world's largest concrete machinery manufacturer and ranks 6th among the top 50 global construction machinery manufacturers.

Besides constantly improving the quality of our products, Sany Group is also committed to providing customers with all-round and efficient services. 15 logistics centers and spare parts warehouses have been set up with logistics and service systems all over the world.

抽考试题

Section I 外贸业务谈判 (50 分)

Directions: You are required to complete a negotiation based on the following situation with at least 80 words.

Situation: You (Shed Johns), Purchasing Manager of MALI Group, are visiting Sany Group. Lin Xiong (the exporter), Marketing Manager of Sany Group, is negotiating with you. After discussing other items, you begin to talk about the problem of the shipment.

You are required to finish the following tasks:

A: You (the importer) B: Lin Xiong (the exporter)

A: _____

(Ask how to ship the goods.)

B: Sure. We usually ship the goods by regular liners.

A: _____

(Require prompt shipment.)

B: I'm afraid it's difficult for us to do so because we can't get all the goods ready soon.

A: _____

(Enquire about the deadline of the loading.)

B: I'm not sure. In order to make it easier for us get the goods ready for shipment, we hope that partial shipment will be allowed.

A: _____

(Refuse partial shipment.)

B: But you should know there is no direct steamer from Shanghai to Gothenburg in two months.

A: _____

(Suggest tramps.)

B: Yes, but tramps are scarce. I'm not sure whether there would be enough tonnage to make a full cargo, even if a tramp could be obtained.

A: _____

(Suggest transshipment.)

B: But transshipment adds to the expenses, risks of damage and sometimes may delay arrival. Anyhow we'll try.

A: _____

(Agree to transshipment if no direct vessel is available.)

B: Yes, we fully understand this, and we'll find out the possible solution and get the goods dispatched within the stipulated time.

A: _____

(Show appreciation.)

任务 2: 外贸英语函电撰写 (40 分)

内容: 包装与运输谈判函电撰写

要求: 理解命题要求, 确定函电性质; 函电格式正确, 字数达标; 表达流畅, 文字通顺, 逻辑合理。

Section II 外贸英语函电撰写

Directions: You are required to write a letter based on the following situation with at least 100 words. (Note: Your letter should adopt the modified-block style.)

Situation: As a Marketing Manager of Sany Group, you are going to write to a Purchasing Manager from MALI Group, to reply to his request for earlier shipment of 5,000 pieces of Bevel Gear. (For more information about the two parties, please refer to the background information given above.)

The following aspects should be included in the letter:

Indicate the inside addresses of the sender, the receiver, the date, the complimentary close and the signature;

State that you have just received the buyer's amendment to the L/C;

State the difficulties of being unable to make earlier shipment---your factories are heavily booked with orders for months ahead;

Inform the importer the best you can do is to ship the goods within the stipulated time; Ask the importer to extend the shipment date and validity of your L/C to October 15 and 31 respectively;

Extend your apology and your promise to ensure the care to the goods and the smoothness to the shipment.

(2) 实施条件

项目	基本实施条件	备注
场地	每个商务英语实训室配置 40 个操作台面和座位, 每个实训室照明通风良好。	必备
设备	每个商务英语实训室配有 1 台服务器、40—50 台计算机, 并安装 Office 办公软件, 配置局域网。	必备
测评专家	每 40 名考生配备 1 名考评员。考评员要求具备至少二年以上从事国际贸易工作经验或三年以上商务英语实践教	必备

	学指导经历。	
--	--------	--

(3) 考核时量

考核时间：90 分钟

(4) 评分标准

模块总分	评价内容	配分	考核点	备注	
岗位核心技能模块一：外贸业务磋商（总分 100 分，占总评分的 50%）	职业素养与操作规范（10 分）	2 分	具备外贸从业人员基本素质，认真严谨、耐心细致、恪守信誉、实事求是、服从安排，听从指挥、举止文明，记 2 分。	在考试过程中不服从安排、举止不当者，记 0 分。	
		2 分	具备外贸从业人员良好的谈判能力、外贸英语函电撰写能力和翻译能力，商务表达得体、规范到位，符合外贸行业对外贸业务、商务翻译、商务管理等相关岗位需求，记 2 分。	考试过程中出现与上述能力及素养不符，扣 1-2 分。	
		2 分	具有良好的跨文化交流和商务礼仪等职业素养，在商务情境中具有敏锐的观察力和灵活的应变能力，记 2 分。	考试过程中出现与上述能力及素养不符，扣 1-2 分。	
		2 分	具备使用办公设备和 Office 办公软件的能力，在考核过程中以及考核结束后，不私自更换电脑、不随意关闭或重启电脑，没征求监考老师同意不随意提前或推迟交卷，记 2 分。	若私自更换电脑、随意关闭或重启电脑，记 0 分。	
		2 分	能严格遵守企业 6S 管理要求（整理、整顿、清扫、清洁、素养、安全），记 2 分。	若未遵守企业 6S 管理要求，记 0 分。	
		15 分	英语表达通顺，语法、句法使用正确，记 15 分。	单词、句型错误每 3 处扣 1 分。	
	作品（90 分）	外贸业务谈判（50 分）	10 分	应对得体，对话流转合理，记 10 分。	对话缺乏连贯性，每处酌情扣 1-2 分。
			10 分	对话中能使用准确的与考核主题谈判的套语、术语记 10 分。	套语、术语搭配不合理，每处扣 0.5 分，搭配错误每处扣 1 分。
			15 分	理解题目要求，信息点完整记 15 分。	信息点每缺失一处扣 1 分。
		外贸英语	5 分	函电格式完全正确，记 5 分。	日期、称呼语、结尾敬语、签名、排

	函电 撰写 (40 分)			版每错2处扣1分。
		5分	字数达到要求,记5分。	每少10词扣1分。
		15分	语言表达通顺,语法、句型使用正确,记15分。	单词、语法每错3处扣1分。
		15分	理解题目要求,信息点完整,记15分。	信息点每缺失一处扣1分。

17. 试题编号: 2-1-17 外贸业务磋商——保险条款谈判

(1) 任务描述

任务1: 商务谈判对话设计

内容: 保险条款谈判对话设计

要求: 了解谈判双方背景,熟悉外贸业务流程和专业术语,灵活运用谈判策略,合理补全谈判对话,语言达到位,交流畅通,环节紧凑。

考试资料

1. 出口方基本情况

Company	Sany Group
Url	http://www.sanygroup.com/group/en-us/
Office Address	Sany Industry Town, Economic and Technological Development Zone, Changsha, Hunan, China
Phone	0086-21-20271802
E-mail	crd@sany.com.cn

2. 进口方基本情况

Company	KK P.L.C.
Url	http://www.kkethiopia.com/
Office Address	Lideta Kifle Ketema, Kebele 13, House No. 895 P.O. Box 702, Addis Ababa, Ethiopia

Phone	251 115 15 90 15
Fax:	251 115 51 99 49
E-mail	kk.plc@ethionet.et

3. 出口方信息

Sany Group began in 1989 as a small welding material factory. Its founders are Liang Wengen, Tang Xiuguo, Mao Zhongwu and Yuan Jinhua. Now it has grown into a global corporation with five industrial parks in China, four R&D and manufacturing bases in America, Germany, India and Brazil, and 24 sales companies around the world. Currently, Sany Group employs over 60,000 people in more than 120 countries.

At Sany Group, we believe that developing and manufacturing of quality, industry-leading products is always a top priority. Each year, Sany Group re-invests 5-7% of its sales revenue into the R&D, making it possible to expand its product lines to concrete, road, port, hoisting, pile driving, excavating machineries and wind energy products. Now as one of the most successful enterprises in China, Sany Group is also the world's largest concrete machinery manufacturer and ranks 6th among the top 50 global construction machinery manufacturers.

Besides constantly improving the quality of our products, Sany Group is also committed to providing customers with all-round and efficient services. 15 logistics centers and spare parts warehouses have been set up with logistics and service systems all over the world.

抽考试题

Section I 外贸业务谈判 (50 分)

Directions: You are required to complete a negotiation based on the following situation with at least 80 words.

Situation: John Black (the importer), Purchasing Manager of KK P.L.C., is visiting Sany Group. You (Lin Xiong), Marketing Manager of Sany Group, are negotiating with him. After discussing other items, you will talk about the problem of insurance for pump and motor parts.

You are required to finish the following tasks:

A: John Black (the importer)

B: You (the exporter)

A: Mr. Lin, glad to see you again.

B: _____
(Greet and ask to discuss insurance details.)

A: Yes, please. We requested an insured amount of twenty- five percent above the invoice value last time we met.

B: _____
(State the insured amount is a bit excessive.)

A: What's your usual practice?

B: _____
 (Suggest the importer to cover the insurance for 110% of the CIF value.)
 A: Then what risks do you usually cover for pump and motor parts?
 B: _____
 (Explain you cover FPA and War Risks.)
 A: Does the risk cover the breakage?
 B: _____
 (Explain the reason for refusal to breakage.)
 A: I see. How will the premium be paid?
 B: _____
 (Explain the premium will be deducted from the commission of 5% payable to the buyer.)
 A: That sounds reasonable. When can you make the insurance?
 B: _____
 (Promise to insure after loading the goods.)
 A: Great. We've settled the problem of the insurance.
 B: _____
 (Show appreciation and end the conversation.)

任务 2: 外贸英语函电撰写 (40 分)

内容: 保险条款谈判函电撰写

要求: 理解命题要求, 确定函电性质; 函电格式正确, 字数达标; 表达流畅, 文字通顺, 逻辑合理。

Section II 外贸英语函电撰写

Directions: You are required to write a letter based on the following situation with at least 100 words. (Note: Your letter should adopt the modified-block style.)

Situation: As the Purchasing Manager of KK P.L.C., you are going to write to the Marketing Manager from Sany Group, to ask for insurance arrangement for 8,500 pieces of pump and motor parts in Order No. SY11605. **(For more information about the two parties, please refer to the background information given above.)**

The following aspects should be included in the letter:

Indicate the inside addresses of the sender, the receiver, the date, the complimentary close and the signature;

State that the original contract was made on CIF basis;

State the reason for requiring insurance arrangement---large distance, potential risks, etc;

Ask for insurance against All Risks and War Risks for 110% of the total invoice value; Promise to refund the premium upon receipt of the debit note and the covering insurance policy;

Express your expectation from the addressee.

(2) 实施条件

项目	基本实施条件	备注
场地	每个商务英语实训室配置 40 个操作台面和座位，每个实训室照明通风良好。	必备
设备	每个商务英语实训室配有 1 台服务器、40—50 台计算机，并安装 Office 办公软件，配置局域网。	必备
测评专家	每 40 名考生配备 1 名考评员。考评员要求具备至少二年以上从事国际贸易工作经验或三年以上商务英语实践教学指导经历。	必备

(3) 考核时量

考核时间：90 分钟

(4) 评分标准

模块总分		评价内容	配分	考核点	备注
岗位核心技能模块一：外贸业务磋商（总分 100 分，占总评分的 50%）	职业素养与操作规范（10 分）	职业素养（6 分）	2 分	具备外贸从业人员基本素质，认真严谨、耐心细致、恪守信誉、实事求是、服从安排，听从指挥、举止文明，记 2 分。	在考试过程中不服从安排、举止不得当者，记 0 分。
			2 分	具备外贸从业人员良好的谈判能力、外贸英语函电撰写能力和翻译能力，商务表达得体、规范到位，符合外贸行业对外贸业务、商务翻译、商务管理等相关岗位需求，记 2 分。	考试过程中出现与上述能力及素养不符，扣 1-2 分。
			2 分	具有良好的跨文化交流和商务礼仪等职业素养，在商务情境中具有敏锐的观察力和灵活的应变能力，记 2 分。	考试过程中出现与上述能力及素养不符，扣 1-2 分。
	作品（90 分）	操作规范（4 分）	2 分	具备使用办公设备和 Office 办公软件的能力，在考核过程中以及考核结束后，不私自更换电脑、不随意关闭或重启电脑，没征求监考老师同意不随意提前或推迟交卷，记 2 分。	若私自更换电脑、随意关闭或重启电脑，记 0 分。
			2 分	能严格遵守企业 6S 管理要求（整理、整顿、清扫、清洁、素养、安全），记 2 分。	若未遵守企业 6S 管理要求，记 0 分。
			15 分	英语表达通顺，语法、句法使用正确，记 15 分。	单词、句型错误每 3 处扣 1 分。
	外贸业务谈判	10 分	应对得体，对话流转合理，记 10 分。	对话缺乏连贯性，	

	(50分)			每处酌情扣 1-2 分。
		10分	对话中能使用准确的与考核主题谈判的套语、术语记 10 分。	套语、术语搭配不合理，每处扣 0.5 分，搭配错误每处扣 1 分。
		15分	理解题目要求，信息点完整记 15 分。	信息点每缺失一处扣 1 分。
	外贸英语函电撰写 (40分)	5分	函电格式完全正确，记 5 分。	日期、称呼语、结尾敬语、签名、排版每错 2 处扣 1 分。
		5分	字数达到要求，记 5 分。	每少 10 词扣 1 分。
		15分	语言表达通顺，语法、句型使用正确，记 15 分。	单词、语法每错 3 处扣 1 分。
		15分	理解题目要求，信息点完整，记 15 分。	信息点每缺失一处扣 1 分。

18. 试题编号：2-1-18 外贸业务磋商——建立贸易关系

(1) 任务描述

任务 1：商务谈判对话设计

内容：建立贸易关系对话设计

要求：了解谈判双方背景，熟悉外贸业务流程和专业术语，灵活运用谈判策略，合理补全谈判对话，语言达到位，交流畅通，环节紧凑。

考试资料

1. 出口方基本情况

Company	Hunan Cereals, Oils and Foodstuffs Import and Export Group Corp. Ltd.
Url	http://www.hunancof.com/yw/index.asp
Office Address	No. 2 Zhuyuan RD, Changsha, Hunan, China

Zip code	410001
E-mail	webmaster@hunancof.com

2. 进口方基本情况

Company	Kraft Foods(Canada Branch)
Url	http://www.kraftfoodscompany.com/home/index.aspx
Office Address	135 Longway Street, Montreal 15122, Canada
Phone	1-416-441-5000
Toll Free	1-847-646-4538

3. 出口方信息

Hunan Cereals, Oils and Foodstuffs Import and Export Group Corp. Ltd. is a solely state-owned enterprise affiliated to and supervised by State-owned Assets Supervision and Administration Commission of Hunan Province. By December 31, 2009, the total assets of the Group amounted to RMB ¥ 1.184 billion and the net assets amounted to RMB ¥ 753 million. Since the group founded in 1952, it has got very fast development in range of merchandise, volume and market of export and the assets has been increased continuously. Specializing in agricultural, by-products and processed products, the Group has always been an import and export enterprise of larger scale and better benefit for many years in Hunan province. Under the background of restructure of the macro-economic and industrial structure, the Group is actively looking for changes and focusing in improving the industry chain of agricultural and by-products as well as developing new business. Besides the major traditional business, such as pig-raising & export and canned fruits export, the Group now has been involved in many fields such as production of agricultural and sideline products, import of medical equipment, domestic trade, property management and export agency service, initially located in well-situation with various business developing.

抽考试题

Section I 外贸业务谈判 (50 分)

Directions: You are required to complete a negotiation based on the following situation with at least 80 words.

Situation: You (Andrew Smith) (the importer), Marketing Manager of Kraft Foods Company, is meeting with Deng Liang (the exporter), Marketing Manager of Hunan Cereals, Oils Foodstuffs Import and Export Group Corp. Ltd. in Mr. Deng's office. You wish to establish business relations with the exporter. You are discussing the possibilities of doing business together.

You are required to finish the following tasks:

A: You (the importer)

B: Deng Liang(the exporter)

- A: _____
(Introduce yourself briefly.)
- B: Good morning, Mr. Smith. I'm Deng Liang. Welcome to our company.
- A: _____
(Indicate the channel of knowing the exporter, and express your wishes to establish business relations.)
- B: We are willing to enter into business relationship with your company on the basis of equality and mutual benefit.
- A: _____
(Make a brief introduction to the company import business (specialize in import of Chinese food, and have been in this line of business for 20 years).)
- B: Our lines are mainly food and oils. We are dedicated to provide our clients the best quality and relatively reasonable cost. Here is our catalogue and price list.
- A: _____
(Express your hope to do more business in this line.)
- B: Your desire coincides with us.
- A: _____
(Offer information of the credit of the company.)
- B: Thank you for your information.
- A: _____
(Show especial interest in Frozen Snow Peas.)
- B: We can provide samples upon request for quality check purpose.
- A: _____
(Ask for lower price.)
- B: I'm sorry, but usually we tend not to offer a too flexible price as the quote is already very favorable. We are proactively working with the market to make necessary adjustment from time to time.
- A: _____
(Ask for the discount for large orders.)
- B: Of course. The discount varies according to your inquiry from 3% to 5%.
- A: That sounds attractive. I'll try to make a specific inquiry soon. B: Then we'll make an offer as soon as possible.

任务 2: 外贸英语函电撰写 (40 分)

内容: 建立贸易关系函电撰写

要求: 理解命题要求, 确定函电性质; 函电格式正确, 字数达标; 表达流畅, 文字通顺, 逻辑合理。

Section II 外贸英语函电撰写

Directions: You are required to write a letter based on the following situation with at least 100 words. (Note: Your letter should adopt the modified-block style.)

Situation: As a sales representative of Hunan Cereals, Oils Foodstuffs Import and Export Group Corp. Ltd., you are going to write to the Purchasing Manager of Kraft Foods, which was introduced by *Yangcheng Evening News*, with the hope of establishing business relations with him. **(For more information about the two parties, please refer to the background information given above.)**

The following aspects should be included in the letter:

Indicate the inside addresses of the sender, the receiver, the date, the complimentary close and the signature;

Indicate information channel;

Extend your wish to establish business relations;

Introduce your company information and main products;

Provide commodity pamphlets for reference.

(2) 实施条件

项目	基本实施条件	备注
场地	每个商务英语实训室配置 40 个操作台面和座位，每个实训室照明通风良好。	必备
设备	每个商务英语实训室配有 1 台服务器、40—50 台计算机，并安装 Office 办公软件，配置局域网。	必备
测评专家	每 40 名考生配备 1 名考评员。考评员要求具备至少二年以上从事国际贸易工作经验或三年以上商务英语实践教学指导经历。	必备

(3) 考核时量

考核时间：90 分钟

(4) 评分标准

模块总分	评价内容	配分	考核点	备注
岗位核心技能模块一：外贸业务	职业素养与操作规范(10分)	2分	具备外贸从业人员基本素质，认真严谨、耐心细致、恪守信誉、实事求是、服从安排，听从指挥、举止文明，记 2 分。	在考试过程中不服从安排、举止不当者，记 0 分。
		2分	具备外贸从业人员良好的谈判能力、外贸英语函电撰写能力和翻译能力，商务表达得体、规范到位，符合外贸行业对外贸业务、商务翻译、商务管理等相关岗位需求，	考试过程中出现与所述能力及素养不符，扣 1-2 分。

磋商 (总分100分,占总评分的50%)			记2分。		
		2分	具有良好的跨文化交流和商务礼仪等职业素养,在商务情境中具有敏锐的观察力和灵活的应变能力,记2分。	考试过程中出现与 所述能力及素养不符,扣1-2分。	
		操作规范 (4分)	2分	具备使用办公设备和 Office 办公软件的能力,在考核过程中以及考核结束后,不私自更换电脑、不随意关闭或重启电脑,没征求监考老师同意不随意提前或推迟交卷,记2分。	若私自更换电脑、 随意关闭或重启电 脑,记0分。
			2分	能严格遵守企业 6S 管理要求(整理、整顿、清扫、清洁、素养、安全),记2分。	若未遵守企业 6S 管理要求,记0分。
	作品 (90分)	外贸 业务 谈判 (50分)	15分	英语表达通顺,语法、句法使用正确,记15分。	单词、句型错误每 3处扣1分。
			10分	应对得体,对话流转合理,记10分。	对话缺乏连贯性, 每处酌情扣1-2 分。
			10分	对话中能使用准确的与考核主题谈判的 套语、术语记10分。	套语、术语搭配不 合理,每处扣0.5 分,搭配错误每处 扣1分。
			15分	理解题目要求,信息点完整记15分。	信息点每缺失一处 扣1分。
		外贸 英语 函电 撰写 (40分)	5分	函电格式完全正确,记5分。	日期、称呼语、结 尾敬语、签名、排 版每错2处扣1分。
			5分	字数达到要求,记5分。	每少10词扣1分。
15分			语言表达通顺,语法、句型使用正确,记15分。	单词、语法每错3 处扣1分。	
15分			理解题目要求,信息点完整,记15分。	信息点每缺失一处 扣1分。	

19. 试题编号: 2-1-19 外贸业务磋商——投诉与索赔谈判

(1) 任务描述

任务1: 商务谈判对话设计

内容: 投诉与索赔谈判对话设计

要求：了解谈判双方背景，熟悉外贸业务流程和专业术语，灵活运用谈判策略，合理补全谈判对话，语言表达到位，交流畅通，环节紧凑。

考试资料

1. 出口方基本情况

Company	Panda Fireworks Group Co., Ltd.
Url	http://pandafireworks.com/
Office Address	NO.271, Liuyang avenue, Liuyang, Hunan, China
Zip code	410304
Phone	086- 0731-83943609
Fax	086- 0731-83940528

2. 进口方基本情况

Company	Exhibit Company
Url	http://exhibitcompany.com/
Office Address	1920 Goodyear Suite E, Ventura CA 93003,U.S.A.
Phone	805 658 1991
Fax	805 642 2108
Toll free	1 800 576 0018

3. 出口方信息

Panda Fireworks Group Co., Ltd, established in 1989, is one of the largest fireworks producers in China, and was the tender winner of the extravagant fireworks for the 2008 Summer Olympics and Paralympics in Beijing. We manufacture, distribute and own all Panda Fireworks brands and also other popular brands in North America as seen below. In addition, we are a one-stop shop for everything related to fireworks. This includes services ranging from procurement to working with customers to tailor their own products.

Devoting to Fireworks Industry, Expecting brighter future

Panda Fireworks Group Co., Ltd boasts several high-class and professional

fireworks and firecrackers production factories as well as large-scale production bases in Liuyang City of Hunan Province and Wanzai City of Jiangxi Province. With more than hundred large and medium-sized fireworks production enterprises at home and abroad, close strategic partnerships have been established, as well as long-term purchasing relationships with more than 300 fireworks production enterprises. The fireworks & firecrackers we have produced and distributed cover a wide range with more than a variety of 300 products for both consuming and professional uses. In order to provide our Chinese and overseas consumers with novel, delicate, more environment-friendly and safer fireworks products, we are committing technological negotiation and close cooperation with some universities and scientific research institutions at home and abroad to build the first-class research center to create new materials, new arts and crafts and new products of fireworks & firecracker in China, also with quality inspection laboratories.

Global strategy with eyes on global market

With eyes on the global market, Panda Fireworks Group Co., Ltd has a precise understanding of the market needs and have established its own sales company, distribution network and strategic partnerships in some major consuming nations of fireworks in the world (such as U.K., Sweden, Denmark, U.S.A., Germany and Italy), through a series of highly efficient overseas marketing and acquisition strategies. With its top stature on product quality, Panda Fireworks has been dedicated priority to providing fireworks and services to all consumers and gained the favor of customers at home and abroad. All the brands as “Panda Fireworks”, “Panda”, “Winda”, “Bright Star” and “Liu-Flower” enjoy high market quota and prestigious reputation in the key fireworks consuming markets. Panda Fireworks has already become one of the largest fireworks exporter in China and one of the largest fireworks producers and traders in the world with the Brand “Panda”.

抽考试题

Section I 外贸业务谈判 (50 分)

Directions: You are required to complete a negotiation based on the following situation with at least 80 words.

Situation: You (Jordan Carter), Purchasing Manager of the Exhibit Company visit Hua Shan (the exporter), Manager of Sales & Marketing Department of Panda Fireworks Group Co. Ltd. You tell Hua Shan that the goods you received were not in line with what they ordered as: Flying Dragon Rocket Fireworks of the specification JSD029 49 shots and JSD030 138 shots. Hua Shan agrees to replace the wrong goods and to be responsible for the related expense.

You are required to finish the following tasks:

A: You, Jordan Carter (the importer) B: Hua Shan (the exporter)

A: _____

(Complain about the wrong goods.)

B: Mr. Carter, What happened? Can you tell me more details?

A: _____

(State the problem and show the survey report.)

B: Let me see. The wrong articles were dispatched. It might be caused by our packing department.

A: _____
(Emphasize the result of the problem.)

B: We are really sorry for the inconvenience we've brought to you.

A: _____
(Inquire about the solution to the problem.)

B: We'll send you the right products to replace the wrong ones.

A: _____
(Ask for the time to replace the goods.)

B: We can assure you that the goods will be shipped to you by the end of this month.

A: _____
(Inquire about how to deal with the wrong goods.)

B: Will you please send them back by the next available ship?

A: _____
(Insist that the exporter be responsible for the expense.)

B: You can rest assured we'll pay for all the expense arising out of this incident.

A: _____
(Express your satisfaction of solving this problem.)

B: Thank you for your understanding.

任务 2: 外贸英语函电撰写 (40 分)

内容: 投诉与索赔谈判函电撰写

要求: 理解命题要求, 确定函电性质; 函电格式正确, 字数达标; 表达流畅, 文字通顺, 逻辑合理。

Section II 外贸英语函电撰写

Directions: You are required to write a letter based on the following situation with at least 100 words. (Note: Your letter should adopt the modified-block style.)

Situation: As a sales representative of Panda Fireworks Group Co. Ltd., you are going to write to a client from the Exhibit Company in U.S.A., who claimed for short delivery. **(For more information about the two parties, please refer to the background information given above.)**

The following aspects should be included in the letter:

Indicate the inside addresses of the sender, the receiver, the date, the complimentary close and the signature;

Indicate the importer claimed for 25 Cartons of 138 shots Flying Dragon Rocket Fireworks;

Explain the reason for short delivery is caused by staff's negligence;

Take some measures to make up;

Express the regrets for the inconvenience caused by the shortage.

(2) 实施条件

项目	基本实施条件	备注
场地	每个商务英语实训室配置 40 个操作台面和座位，每个实训室照明通风良好。	必备
设备	每个商务英语实训室配有 1 台服务器、40—50 台计算机，并安装 Office 办公软件，配置局域网。	必备
测评专家	每 40 名考生配备 1 名考评员。考评员要求具备至少二年以上从事国际贸易工作经验或三年以上商务英语实践教学指导经历。	必备

(3) 考核时量

考核时间：90 分钟

(4) 评分标准

模块总分	评价内容	配分	考核点	备注
岗位核心技能模块一：外贸业务磋商（总分 100 分，占总评分的 50%）	职业素养（6 分）	2 分	具备外贸从业人员基本素质，认真严谨、耐心细致、恪守信誉、实事求是、服从安排，听从指挥、举止文明，记 2 分。	在考试过程中不服从安排、举止不当者，记 0 分。
		2 分	具备外贸从业人员良好的谈判能力、外贸英语函电撰写能力和翻译能力，商务表达得体、规范到位，符合外贸行业对外贸业务、商务翻译、商务管理等相关岗位需求，记 2 分。	考试过程中出现与上述能力及素养不符，扣 1-2 分。
		2 分	具有良好的跨文化交流和商务礼仪等职业素养，在商务情境中具有敏锐的观察力和灵活的应变能力，记 2 分。	考试过程中出现与上述能力及素养不符，扣 1-2 分。
	操作规范（4 分）	2 分	具备使用办公设备和 Office 办公软件的能力，在考核过程中以及考核结束后，不私自更换电脑、不随意关闭或重启电脑，没征求监考老师同意不随意提前或推迟交卷，记 2 分。	若私自更换电脑、随意关闭或重启电脑，记 0 分。
		2 分	能严格遵守企业 6S 管理要求（整理、整顿、清扫、清洁、素养、安全），记 2 分。	若未遵守企业 6S 管理要求，记 0 分。
	作品	外贸	15 分	英语表达通顺，语法、句法使用正确，记

	(90分)	业务谈判 (50分)		15分。	3处扣1分。
			10分	应对得体，对话流转合理，记10分。	对话缺乏连贯性，每处酌情扣1-2分。
			10分	对话中能使用准确的与考核主题谈判的套语、术语记10分。	套语、术语搭配不合理，每处扣0.5分，搭配错误每处扣1分。
			15分	理解题目要求，信息点完整记15分。	信息点每缺失一处扣1分。
	外贸英语 函电 撰写 (40分)	5分	函电格式完全正确，记5分。	日期、称呼语、结尾敬语、签名、排版每错2处扣1分。	
		5分	字数达到要求，记5分。	每少10词扣1分。	
		15分	语言表达通顺，语法、句型使用正确，记15分。	单词、语法每错3处扣1分。	
		15分	理解题目要求，信息点完整，记15分。	信息点每缺失一处扣1分。	

20. 试题编号：2-1-20 外贸业务磋商——价格谈判

(1) 任务描述

任务1：商务谈判对话设计

内容：价格谈判对话设计

要求：了解谈判双方背景，熟悉外贸业务流程和专业术语，灵活运用谈判策略，合理补充谈判对话，语言表达到位，交流畅通，环节紧凑。

考试资料

1. 出口方基本情况

Company	Hunan Cereals, Oils and Foodstuffs Import and Export Group Corp. Ltd.
Url	http://www.hunancof.com/yw/index.asp

Office Address	No. 2 Zhuyuan RD, Changsha, Hunan, China
Zip code	410001
E-mail	webmaster@hunancof.com

2. 进口方基本情况

Company	Charoen Pokphand Group
Url	http://www.cpthailand.com/
Office Address	75 Changkaichi Street, Bangkok 002, Thailand
Fax	(66 2) 638 2741
Phone	(66 2) 625 8000 ext. 8127-8130
E-mail	cp@cpthailand.com

3. 出口方信息

Hunan Cereals, Oils and Foodstuffs Import and Export Group Corp. Ltd. is a solely state-owned enterprise affiliated to and supervised by State-owned Assets Supervision and Administration Commission of Hunan Province. By December 31, 2009, the total assets of the Group amounted to RMB ¥ 1.184 billion and the net assets amounted to RMB ¥ 753 million. Since the group founded in 1952, it has got very fast development in range of merchandise, volume and market of export and the assets has been increased continuously. Specializing in agricultural, by-products and processed products, the Group has always been an import and export enterprise of larger scale and better benefit for many years in Hunan province. Under the background of restructure of the macro-economic and industrial structure, the Group is actively looking for changes and focusing in improving the industry chain of agricultural and by-products as well as developing new business. Besides the major traditional business, such as pig-raising & export and canned fruits export, the Group now has been involved in many fields such as production of agricultural and sideline products, import of medical equipment, domestic trade, property management and export agency service, initially located in well-situation with various business developing.

抽考试题

Section I 外贸业务谈判 (50分)

Directions: You are required to complete a negotiation based on the following situation with at least 80 words.

Situation: You (Andrew Smith), Marketing Manager of Charoen Pokphand Group, is meeting Deng Liang (the exporter), Marketing Manager of Hunan Cereals,

Oils Foodstuffs Import and Export Group Corp. Ltd.. You want to know the price of Sunflower Seed, and ask about the commission of doing business with Deng.

You are required to finish the following tasks:

A: You (the importer)

B: Deng Liang (the exporter)

A: _____

(Express your pleasure to have the chance to visit the company.)

B: It's a great pleasure, Mr. Smith, to have the opportunity of meeting you. I believe you have seen the exhibits in the show room. May I know what particular items you are interested in?

A: _____

(Show interest in Sunflower Seed, and inquire lowest quotations, CIF Bangkok.)

B: Thank you for your inquiry. Would you tell us the quantity you require so as to enable us to work out the offers?

A: _____

(Demand an indication of price.)

B: Here are our FOB price lists. All the prices in the lists are subject to our confirmation.

A: _____

(Ask about the commission, 3 to 5 percent commission from European suppliers.)

B: As a rule we do not allow any commission. But if the order is large enough, we'll consider it.

A: _____

(Wish to do business on commission basis (2 or 3 percent).)

B: Usually a 1% commission is given to our agent. Generally speaking, commission depends on the quantity of goods ordered.

A: _____

(Want to have large orders.)

B: According to your estimate, what is the maximum annual turnover you could fulfill?

A: _____

(Ask for 2 percent commission for 2000 M/T annually.)

B: We'll discuss this when you place your order with us.

A: _____

(Promise to order as soon as possible.)

B: We expect that.

任务 2: 外贸英语函电撰写 (40 分)

内容: 价格谈判函电撰写

要求: 理解命题要求, 确定函电性质; 函电格式正确, 字数达标;

表达流畅, 文字通顺, 逻辑合理。

Section II 外贸英语函电撰写

Directions: You are required to write a letter based on the following situation with at least 100 words. (Note: Your letter should adopt the modified-block style.)

Situation: As the Purchasing Manager of Charoen Pokphand Group, you are going to write to a sales representative of Hunan Cereals, Oils Foodstuffs Import and Export Group Corp. Ltd. to negotiate the prices with him. **(For more information about the two parties, please refer to the background information given above.)**

The following aspects should be included in the letter:

Indicate the inside addresses of the sender, the receiver, the date, the complimentary close and the signature;

Extend your thanks for their quotation for 500MT of sunflower seeds on May 12;

Indicate the importer's quotation is too high and ask for cutting the prices by 8%;

Request for arranging insurance against All Risks in Stockholm and having the business done under CIF instead of CRF Bangkok.

(2) 实施条件

项目	基本实施条件	备注
场地	每个商务英语实训室配置 40 个操作台面和座位，每个实训室照明通风良好。	必备
设备	每个商务英语实训室配有 1 台服务器、40—50 台计算机，并安装 Office 办公软件，配置局域网。	必备
测评专家	每 40 名考生配备 1 名考评员。考评员要求具备至少二年以上从事国际贸易工作经验或三年以上商务英语实践教学指导经历。	必备

(3) 考核时量

考核时间：90 分钟

(4) 评分标准

模块总分	评价内容	配分	考核点	备注
岗位核心技能模块一：外贸	职业素养与操作规范 (10 分)	2 分	具备外贸从业人员基本素质，认真严谨、耐心细致、恪守信誉、实事求是、服从安排，听从指挥、举止文明，记 2 分。	在考试过程中不服从安排、举止不当者，记 0 分。
		2 分	具备外贸从业人员良好的谈判能力、外贸英语函电撰写能力和翻译能力，商务表达得体、规范到位，符合外贸行业对外贸业	考试过程中出现与上述能力及素养不符，扣 1-2 分。

业务磋商 (总分100分,占总评分的50%)	操作规范 (4分)		务、商务翻译、商务管理等相关岗位需求,记2分。		
		2分	具有良好的跨文化交流和商务礼仪等职业素养,在商务情境中具有敏锐的观察力和灵活的应变能力,记2分。	考试过程中出现与 所述能力及素养不符,扣1-2分。	
		2分	具备使用办公设备和 Office 办公软件的能力,在考核过程中以及考核结束后,不私自更换电脑、不随意关闭或重启电脑,没征求监考老师同意不随意提前或推迟交卷,记2分。	若私自更换电脑、 随意关闭或重启电脑,记0分。	
		2分	能严格遵守企业 6S 管理要求(整理、整顿、清扫、清洁、素养、安全),记2分。	若未遵守企业 6S 管理要求,记0分。	
	作品 (90分)	外贸业务谈判 (50分)	15分	英语表达通顺,语法、句法使用正确,记15分。	单词、句型错误每 3处扣1分。
			10分	应对得体,对话流转合理,记10分。	对话缺乏连贯性, 每处酌情扣1-2分。
			10分	对话中能使用准确的与考核主题谈判的套语、术语记10分。	套语、术语搭配不 合理,每处扣0.5分,搭配错误每处扣1分。
			15分	理解题目要求,信息点完整记15分。	信息点每缺失一处 扣1分。
		外贸英语函电撰写 (40分)	5分	函电格式完全正确,记5分。	日期、称呼语、结 尾敬语、签名、排 版每错2处扣1分。
			5分	字数达到要求,记5分。	每少10词扣1分。
15分			语言表达通顺,语法、句型使用正确,记15分。	单词、语法每错3 处扣1分。	
15分			理解题目要求,信息点完整,记15分。	信息点每缺失一处 扣1分。	

三、岗位核心技能模块项目二 —— 外贸单证缮制

1. 试题编号: 2-2-1 信用证审核、单证缮制

(1) 任务描述

任务 1: 信用证审核

熟悉 UCP600 相关条款；读懂外贸合同条款；读懂并审核 L/C 各条款；修改 L/C 中的问题条款。

注意：考试资料中的信用证为错误的信用证，考试中涉及到信用证的信息必须参考修改正确的信用证的信息，否则造成的制单错误将不计分。

任务 2：商业发票缮制

分析信用证中涉及商业发票缮制的相关条款；准确缮制商业发票；确保缮制的商业发票与信用证的条款一致。

任务 3：提单缮制

分析信用证的装运条款；准确缮制提单；确保缮制的提单与信用证的条款一致。

任务 4：汇票缮制

分析信用证中涉及汇票缮制的相关条款；准确缮制汇票；确保缮制的汇票与信用证的条款一致。

背景资料

1. 出口方基本情况

Company	HUNAN PROVINCIAL LIGHT INDUSTRIAL PRODUCTS I/E CORP.
Url	http://ccn.mofcom.gov.cn/923748
Office Address	NO. 4 EAST WUYI ROAD, CHANGSHA, HUNAN, CHINA
Zip code	410001
Phone	86-731-82287135
Fax	86-731-82287136
E-mail	hnqgyp_123@163.com

2. 进口方基本情况

Company	ALDI GROUP COMPANY
---------	--------------------

Url	http://aldi.com.au/index.htm
Office Address	MINCHINBURY REGION, LOCKED BAG 56, ST MARYS DELIVERY CENTRE, NSW 2760, AUSTRALIA
Tollfree	800-426-0818
Phone	02-9675-9000
Fax	02-9675-9001

3. 合同

销售合同

SALES CONTRACT

SELLER: HUNAN PROVINCIAL LIGHT INDUSTRIAL PRODUCTS I/E CORP.
 NO. 4 EAST WUYI ROAD, CHANGSHA, HUNAN, CHINA

NO.: HLIP-05128
DATE: MAR. 20, 2022
SIGNED IN: CHANGSHA

BUYER: ALDI GROUP COMPANY
 MINCHINBURY REGION, LOCKED BAG 56, ST MARYS DELIVERY CENTRE, NSW 2760, AUSTRALIA

This contract is made by and agreed between the BUYER and SELLER, in accordance with the terms and conditions stipulated below.

1. Commodity & Specification	2. Quantity	3. Unit Price & Trade Terms	4. Amount
			CIF SYDNEY
3W GU10 LED SPOT BASE GU10, INPUT AC100-240V, POWER 1*3W	100,000 PCS	USD 0.8/PC	USD 80,000.00
Total:	100,000 PCS		USD 80,000.00

5. Total Value SAY U.S. DOLLARS EIGHTY THOUSAND ONLY.

6. Packing 100 PCS/CTN
 SIZE OF CARTON 300MM×240MM×500MM
 PACKED IN 1,000 CARTONS

7. Shipping Marks N/M

- 8. Time of Shipment & means of Transportation** TO BE EFFECTED BEFORE THE END OF APRIL 2022 FROM SHANGHAI TO SYDNEY WITH PARTIAL SHIPMENT NOT ALLOWED AND TRANSSHIPMENT ALLOWED.
- 9. Port of Loading & Destination** FROM: SHANGHAI
TO: SYDNEY
- 10. Insurance** THE SELLER SHALL COVER INSURANCE AGAINST ALL RISKS & WAR RISK FOR 110% OF THE TOTAL INVOICE VALUE AS PER THE RELEVANT OCEAN MARINE CARGO OF P.I.C.C. DATED 1/1/1981
- 11. Terms of Payment** TO BE MADE BY SIGHT L/C
- 12. Remarks**

The Buyer	The Seller
ALDI GROUP COMPANY	HUNAN PROVINCIAL LIGHT INDUSTRIAL PRODUCTS I/E CORP.
(signature)	(signature)

4.信用证

27:	SEQUENCE OF TOTAL	1/1
40A:	FORM OF DOCUMENTARY CREDIT	REVOCABLE
20:	DOCUMENTARY CREDIT NUMBER	45238/03
31C:	DATE OF ISSUE	220330
31D:	DATE AND PLACE OF EXPIRY	220521 CHINA
50:	APPLICANT ALD GROUP COMPANY MINCHINBURY REGION, LOCKED BAG 56, ST MARYS DELIVERY CENTRE, NWS 260, AUSTRALIA	
59:	BENEFICIARY HUNAN PROVINCIAL LIGHT INDUSTRIAL PRODUCTS I/E CORP. NO. 4 EAST WUYI ROAD, CHANGSHA, HUNAN, CHINA	
32B:	AMOUNT	USD 80,000.00

39B:	CREDIT AMT	NOT EXCEEDING
41D:	AVAILABLE WITH BY	ANY BANK IN CHINA
42C:	DRAFTS AT	30 DAYS AFTER SIGHT
42D:	DRAWEE	CITI BANK SYDNEY BRANCH
43P:	PARTIAL SHIPMENTS	ALLOWED
43T:	TRANSSHIPMENT	ALLOWED
44A:	LOADING ON BOARD	SHANGHAI, CHINA
44B:	FOR TRANSPORTATION TO	SYDNEY, AUSTRALIA
44C:	LATEST DATE OF SHIPMENT	220430
45A:	DESCRIPTION OF GOODS	
	100,000 PCS 3W GU10 LED SPOT	
	BASE GU10, INPUT AC100-240V, POWER 1*3W	
	USD 0.8/PC CFR SYDNEY	
46A:	DOCUMENTS REQUIRED	
	+SIGNED COMMERCIAL INVOICE IN TRIPLICATE.	
	+PACKING LIST IN TRIPLICATE.	
	+CERTIFICATE OF ORIGIN GSP CHINA FORM A, ISSUED BY THE CHAMBER OF COMMERCE OR OTHER AUTHORITY DULY ENTITLED FOR THIS PURPOSE.	
	+FULL SET OF CLEAN ON BOARD OCEAN BILLS OF LADING, MADE OUT TO ORDER OF SHIPPER AND BLANK ENDORSED AND MARKED "FREIGHT PREPAID" AND NOTIFY APPLICANT.	
	+FULL SET OF NEGOTIABLE INSURANCE POLICY OR CERTIFICATE BLANK ENDORSED FOR 120 PCT OF INVOICE VALUE COVERING ALL RISKS AND WAR RISK.	
	+SHIPPING ADVICES MUST BE SENT TO APPLICANT ON THE DATE OF SHIPMENT ADVISING SHIPPING MARKS, COMMODITY NAME, CARTON NUMBERS, TOTAL GROSS WEIGHT, VESSEL NAME, BILL OF LADING NO., PORT OF LOADING, DESTINATION, CONTRACT NO., INVOICE NO., LETTER OF CREDIT NO.	
	+COPY OF LETTER FROM BENEFICIARY TO OUR APPLICANT EVIDENCING A NON NEGOTIABLE BILL OF LADING TOGETHER WITH COPY OF OTHER DOCUMENTS WAS SENT DIRECTLY TO THEM AFTER ONE DAY FROM SHIPMENT DATE.	
71B:	CHARGES	ALL BANKING CHARGES OUTSIDE AUSTRALIA ARE FOR ACCOUNT OF APPLICANT.
48:	PERIOD FOR PRESENTATION	DOCUMENTS MUST BE PRESENTED WITHIN 15 DAYS AFTER THE DATE OF SHIPMENT BUT WITHIN THE VALIDITY OF THE CREDIT.

5.相关资料

(1)INVOICE NO.: CS54691

(2)INVOICE DATE: APRIL 04, 2022

(3)PACKING

G. W.(KGS/CARTON)	N. W.(KGS/CARTON)	MEAS (CBM/CARTON)
5.8	5.2	0.036

100 PCS/CTN

PACKED IN 1,000 CARTONS

TOTAL ONE 40' CONTAINER

(4)VESSEL: YANGFAN V. 279

(5)B/L NO.: ASCS1281861

(6)B/L DATE: APRIL 19, 2022

(7)POLICY NO.: SH160417

(8)REFERENCE NO.: 20220316

抽考试题

1、请根据考试资料中的合同 3 审核错误的信用证 4，指出不符之处并修正。

(本题共 16 分)

1. _____
2. _____
3. _____
4. _____
5. _____
6. _____
7. _____
8. _____

2、请根据以上资料缮制商业发票。(本题共 34 分)

(注：信用证的信息必须是修正后的正确信息)

湖南轻工产品进出口公司

Hunan Provincial Light Industrial Products I/E Corp.

No. 4 East Wuyi Road, Changsha, Hunan, China

TEL: 86-731-82287135 FAX: 86-731-82287136

商业发票

COMMERCIAL INVOICE

TO:		INVOICE NO.:		
		INVOICE DATE:		
		S/C NO.:		
FROM:		L/C NO.:		
TO:		L/C DATE:		
Marks and Numbers	Description of Goods	Quantity	Unit Price	Amount
Total:				

SAY TOTAL:

HUNAN PROVINCIAL LIGHT INDUSTRIAL PRODUCTS I/E CORP.

湖南轻工产品进出口公司

李明远

(Authorized Signature)

3、请根据以上资料缮制提单。（本题共 30 分）

（注：信用证的信息必须是修正后的正确信息）

Shipper		BILL OF LADING B/L NO.: 中国远洋运输公司 CHINA OCEAN SHIPPING ORIGINAL	
Consignee or order			
Notify Party			
*Pre carriage by	*Place of Receipt		
Ocean Vessel Voy. No.	Port of Loading		
Port of discharge	*Final destination	Freight payable at	Number original Bs/L
Marks and Numbers	Number and kind of packages; Description	Gross weight	Measurement m ³
<hr/> TOTAL PACKAGES(IN WORDS) <hr/>			
Freight and charges			Place and date of issue Signed for the Carrier SHANGHAI OCEAN SHIPPING CO., LTD. 丁浩

*Applicable only when document used as a Through Bill of Lading

4、请根据以上资料缮制汇票。（本题共 10 分）

（注：信用证的信息必须是修正后的正确信息）

BILL OF EXCHANGE

Drawn under _____

L/C No. _____

Dated _____

No. _____ Exchange for _____ Changsha, China.

At _____ sight of this FIRST of Exchange (Second of exchange being unpaid)

Pay to the order of _____

The sum of _____

To _____

HUNAN PROVINCIAL LIGHT INDUSTRIAL PRODUCTS I/E CORP.

**湖南轻工产品进出口公司
李明远**

(Authorized Signature)

(2) 实施条件

项目	基本实施条件	备注
场地	每个商务英语实训室配置 40 个操作台面和座位，每个实训室照明通风良好。	必备

设备	每个商务英语实训室配有 1 台服务器、40—50 台计算机，并安装 Office 办公软件，配置局域网。	必备
测评专家	每 40 名考生配备 1 名考评员。考评员要求具备至少二年以上从事国际贸易工作经验或二年以上外贸单证缮制实践教学指导经历。	必备

(3) 考核时量

考核时间：90 分钟

(4) 评分标准

模块总分	评价内容	配分		考核点	备注
岗位核心技能模块 项目二： 外贸单证缮制 (总分 100 分，占总评分的 50%)	职业素养与操作规范 (10 分)	职业素养 (6 分)	2 分	(1) 具备外贸从业人员基本素质，认真严谨、耐心细致、恪守信誉、实事求是、服从安排，听从指挥、举止文明；	在考试过程中不服从安排、举止不得当者，记 0 分。
			2 分	具备对外贸合同及信用证信息甄别正误及修正能力、正确缮制单证能力，做到数据计算准确、信息填写正确、单据填写完整；	与所述能力及素养不符，扣 1-2 分。
			2 分	(3) 具备正确规范操作外贸电商平台能力，具有对外贸产品筛选关键信息的能力，符合外贸行业对外贸电商运营等相关岗位需求。	与所述能力及素养不符，扣 1-2 分。
		操作规范 (4 分)	2 分	(1) 具备使用办公设备和 Office 办公软件的能力，在考核过程中以及考核结束后，不私自更换电脑、不随意关闭或重启电脑，没征求监考老师同意不随意提前或推迟交卷；	若私自更换电脑、随意关闭或重启电脑，记 0 分。
	2 分		(2) 能严格遵守企业 6S 管理要求（整理、整顿、清扫、清洁、素养、安全）。	若未遵守企业 6S 管理要求，记 0 分。	
	作品 (90 分)	信用证审核 (16 分)	2 分	(1) 买卖双方的名称与地址是否有误；	信用证审核共 12 个考核点，有 8 处错误，
			2 分	(2) 品名、规格、数量、重量、单价是否有误；	

		2分	(3) 货物包装、体积是否有误;	每处2分, 找出错误计1分, 修正错误计1分。
		2分	(4) 使用的贸易术语是否有误;	
		2分	(5) 合同金额和币种是否有误;	
		2分	(6) 合同中溢短装条款是否有误;	
		2分	(7) 唛头是否有误;	
		2分	(8) 起运港和目的港是否有误;	
		2分	(9) 分批装运和转运是否有误;	
		2分	(10) 保险险别、保险金额是否有误;	
		2分	(11) 最迟装运期是否有误;	
		2分	(12) 汇票的付款期限是否有误; 单据条款是否有误。	
		商业发票缮制 (34分)	2分	
	2分		(2) 商业发票号码: 填写准确无误;	
	2分		(3) 商业发票开立日期: 填写准确无误;	
	2分		(4) 合同号码: 填写准确无误;	
	2分		(5) 信用证号码: 填写准确无误;	
	2分		(6) 信用证日期: 填写准确无误;	
	2分		(7) 运输路线装运地: 填写准确无误;	
	2分		(8) 运输路线目的地: 填写准确无误;	
	2分	(9) 价格术语: 填写准确无误;		
2分	(10) 货物唛头: 填写准确无误;			
2分	(11) 货物描述: 品名拼写正确, 规格信息填写准确无误;			
2分	(12) 货物数量: 填写准确无误;			
2分	(13) 货物单价及单位: 填写准确无误;			
2分	(14) 货物金额: 填写准确无误;			

			2分	(15) 货物数量总计：计算准确无误；	
			2分	(16) 货物金额总计：计算准确无误，货币名称正确；	
			2分	(17) 总金额大写：英文拼写正确。	
		提单缮制 (30分)	2分	(1) 发货人条款：根据信用证中有关提单条款的规定进行正确的填写；	提单缮制部分共15个考核点，每处计2分，未填、错填每处扣2分。拼写错误每3处扣1分。
			2分	(2) 收货人条款：根据信用证中有关提单条款的规定进行正确的填写；	
			2分	(3) 通知人条款：根据信用证中有关提单条款的规定进行正确的填写；	
			2分	(4) 提单号码：填写准确无误；	
			2分	(5) 船名及船次：填写准确无误；	
			2分	(6) 装货港：填写准确无误；	
			2分	(7) 卸货港：填写准确无误；	
			2分	(8) 运费支付地点：填写准确无误；	
			2分	(9) 提单份数：填写准确无误；	
			2分	(10) 唛头：填写准确无误；	
			2分	(11) 货物描述条款：包括货物的总称、包装的总数量等，填写准确无误；	
			2分	(12) 毛重条款：计算准确无误，单位描述正确；	
			2分	(13) 体积条款：计算准确无误，单位描述正确；	
			2分	(14) 包装总数量：填写准确无误；	
			2分	(15) 提单签发地点及日期：填写准确无误。	
		汇票缮制	1分	(1) 出票条款：开证行完整名称，拼写准确无误；	汇票缮制部分共10个考核

		(10分)	1分	(2) 信用证号码: 填写准确无误;	点, 每处计1分, 未填、错填每处扣1分。拼写错误每3处扣1分。
			1分	(3) 信用证开证日期: 填写准确无误;	
			1分	(4) 汇票号码: 填写准确无误;	
			1分	(5) 汇票日期: 填写准确无误;	
			1分	(6) 汇票金额小写: 填写准确无误;	
			1分	(7) 汇款期限: 填写准确无误;	
			1分	(8) 收款人: 信用证下以议付行为收款人, 托收汇票下以托收行(出口地银行)为收款人: 信息完整无误, 拼写正确;	
			1分	(9) 金额及币种大写: 币种与金额必须与信用证保持一致, 拼写准确无误;	
			1分	(10) 付款人: 信用证项下付款人为开证行或指定银行: 信息完整无误, 拼写正确。	

2. 试题编号: 2-2-2 信用证审核、单证缮制

(1) 任务描述

任务 1: 信用证审核

熟悉 UCP600 相关条款; 读懂外贸合同条款; 读懂并审核 L/C 各条款; 修改 L/C 中的问题条款。

注意: 考试资料中的信用证为错误的信用证, 考试中涉及到信用证的信息必须参考修改正确的信用证的信息, 否则造成的制单错误将不计分。

任务 2: 商业发票缮制

分析信用证中涉及商业发票缮制的相关条款; 准确缮制商业发票; 确保缮制的商业发票与信用证的条款一致。

任务 3：提单缮制

分析信用证的装运条款；准确缮制提单；确保缮制的提单与信用证的条款一致。

任务 4：汇票缮制

分析信用证中涉及汇票缮制的相关条款；准确缮制汇票；确保缮制的汇票与信用证的条款一致。

背景资料

1、出口方基本情况

Company	HUNAN PROVINCIAL LIGHT INDUSTRIAL PRODUCTS I/E CORP.
Url	http://ccn.mofcom.gov.cn/923748
Office Address	NO. 4 EAST WUYI ROAD, CHANGSHA, HUNAN, CHINA
Zip code	410001
Phone	86-731-82287135
Fax	86-731-82287136
E-mail	hnqgyp_123@163.com

2、进口方基本情况

Company	SEOW KHIM POLYTHELENE CO PTE LTD
Url	http://www.partyware.com.sg/index.htm
Office Address	28 LOYANG DRIVE SKP INDUSTRIAL BUILDING, SINGAPORE
Tollfree	无
Phone	(+65) 6545 2828
Fax	(+65) 6542 1200

3、合同

销售合同

SALES CONTRACT

SELLER: HUNAN PROVINCIAL LIGHT INDUSTRIAL PRODUCTSNO.: HLIP-45037
 I/E CORP. **DATE:** JAN. 3, 2022
 NO. 4 EAST WUYI ROAD, CHANGSHA, HUNAN, CHINA **SIGNED IN:** CHANGSHA

BUYER: SEOW KHIM POLYTHELENE CO PTE LTD
 28 LOYANG DRIVE SKP INDUSTRIAL BUILDING, SINGAPORE

This contract is made by and agreed between the BUYER and SELLER, in accordance with the terms and conditions stipulated below.

1. Commodity & Specification	2. Quantity	3. Unit Price & Trade Terms	4. Amount
CIF SINGAPORE			
PORCELAIN DINNER SET			
WWD0004 20-PIECE DINNERWARE SET	800 SETS	USD 4.4/SET	USD 3,520.00
WWD0004 47-PIECE DINNERWARE SET	1000 SETS	USD 10.34/SET	USD10,340.00
Total:	1,800 SETS		USD 13,860.00

5. Total Value SAY U.S. DOLLARS THIRTEEN THOUSAND EIGHT HUNDRED AND SIXTY ONLY.

6. Packing WWD0004 20-PIECE: PACKED IN 2SETS/CARTON
 WWD0004 47-PIECE: PACKED IN ONE CARTON OF 1 SET EACH
 TOTAL: 1,400 CARTONS.

7. Shipping Marks N/M

8. Time of Shipment & means of Transportation TO BE EFFECTED BEFORE THE END OF FEBURARY 2022 FROM SHANGHAI TO SINGAPORE WITH PARTIAL SHIPMENT AND TRANSSHIPMENT NOT ALLOWED.

9. Port of Loading & Destination FROM: SHANGHAI
 TO: SINGAPORE

10. Insurance THE SELLER SHALL COVER INSURANCE AGAINST W.P.A. AND CLASH & BREAKAGE & WAR RISK FOR 110% OF THE TOTAL INVOICE VALUE AS PER THE RELEVANT OCEAN MARINE CARGO OF P.I.C.C. DATED 1/1/1981

11. Terms of Payment TO BE MADE BY SIGHT L/C

12. Remarks

The Buyer

SEOW KHIM POLYTHELENE CO
 PTE LTD.

The Seller

HUNAN PROVINCIAL LIGHT
 INDUSTRIAL PRODUCTS I/E CORP.

(signature)

(signature)

4、信用证

27:	SEQUENCE OF TOTAL	1/1
40A:	FORM OF DOCUMENTARY CREDIT	IRREVOCABLE
20:	DOCUMENTARY CREDIT NUMBER	31173
31C:	DATE OF ISSUE	220114
31D:	DATE AND PLACE OF EXPIRY	220321 SINGAPORE
50:	APPLICANT SEOW KHIM POLYTHELENE CO PTE LTD. 27 LOYANG DRIVE, SKP INDUSTRIAL BUILDING, SINGAPORE	
59:	BENEFICIARY HUNAN PROVINCIAL LIGHT INDUSTRIAL PRODUCTS I/E LTD. NO. 4 EAST WUYI ROAD, CHANGSHA, HUNAN, CHINA	
32B:	AMOUNT	USD13,860.00
39B:	CREDIT AMT	NOT EXCEEDING
41D:	AVAILABLE WITH BY	ANY BANK IN CHINA
42C:	DRAFTS AT	30 DAYS AFTER SIGHT
42D:	DRAWEE	CITI BANK, SINGAPORE BRANCH
43P:	PARTIAL SHIPMENTS	NOT ALLOWED
43T:	TRANSSHIPMENT	ALLOWED
44A:	LOADING ON BOARD	NINGBO, CHINA
44B:	FOR TRANSPORTATION TO	SINGAPORE
44C:	LATEST DATE OF SHIPMENT	220228
45A:	DESCRIPTION OF GOODS 500 SETS WWD0004 20-PIECE USD 4.40/SET 1000 SETS WWD0004 47-PIECE USD 10.34/SET CIF SINGAPORE	
46A:	DOCUMENTS REQUIRED +SIGNED COMMERCIAL INVOICE IN TRIPLICATE. +PACKING LIST IN TRIPLICATE. +CERTIFICATE OF ORIGIN GSP CHINA FORM A, ISSUED BY THE CHAMBER OF	

COMMERCE OR OTHER AUTHORITY DULY ENTITLED FOR THIS PURPOSE.

+FULL SET OF CLEAN ON BOARD OCEAN BILLS OF LADING, MADE OUT TO ORDER OF SHIPPER AND BLANK ENDORSED AND MARKED "FREIGHT PREPAID" AND NOTIFY APPLICANT.

+FULL SET OF NEGOTIABLE INSURANCE POLICY OR CERTIFICATE BLANK ENDORSED FOR 110 PCT OF INVOICE VALUE COVERING W.P.A. AND CLASH.

+SHIPPING ADVICES MUST BE SENT TO APPLICANT ON THE DATE OF SHIPMENT ADVISING SHIPPING MARKS, COMMODITY NAME, CARTON NUMBERS, TOTAL GROSS WEIGHT, VESSEL NAME, BILL OF LADING NO., PORT OF LOADING, DESTINATION, CONTRACT NO., INVOICE NO., LETTER OF CREDIT NO.

+COPY OF LETTER FROM BENEFICIARY TO OUR APPLICANT EVIDENCING A NON NEGOTIABLE BILL OF LADING TOGETHER WITH COPY OF OTHER DOCUMENTS WAS SENT DIRECTLY TO THEM AFTER ONE DAY FROM SHIPMENT DATE.

- 71B: CHARGES ALL BANKING CHARGES OUTSIDE SINGAPORE ARE FOR ACCOUNT OF BENEFICIARY.
- 48: PERIOD FOR PRESENTATION DOCUMENTS MUST BE PRESENTED WITHIN 15 DAYS AFTER THE DATE OF SHIPMENT BUT WITHIN THE VALIDITY OF THE CREDIT.

5、相关资料

- (1) INVOICE NO.: JCS04860
- (2) INVOICE DATE: JANUARY 24, 2022
- (3) PACKING

	G. W.(KGS/CTN)	N. W.(KGS/CTN)	MEAS (CBM/CTN)
20-Piece Dinnerware Set:	8	7	0.045
47-Piece Dinnerware Set:	12	9	0.070

PACKED IN 1,400 CARTONS

TOTAL TWO 40' CONTAINERS

- (4) VESSEL: GOLDEN GATE BRIDGE V. 10W
- (5) B/L NO.: COSU66089083

(6) B/L DATE: FEBURARY 05, 2022

(7) POLICY NO.: FR160206

(8) REFERENCE NO.: 20220207

抽考试题

1、请根据考试资料中的合同 3 审核错误的信用证 4，指出不符之处并修正。

(本题共 16 分)

1. _____
2. _____
3. _____
4. _____
5. _____
6. _____
7. _____
8. _____

2、请根据以上资料缮制商业发票。(本题共 34 分)

(注：信用证的信息必须是修正后的正确信息)

湖南轻工产品进出口公司

Hunan Provincial Light Industrial Products I/E Corp.

No. 4 East Wuyi Road, Changsha, Hunan, China

TEL: 86-731-82287135 FAX: 86-731-82287136

商业发票

COMMERCIAL INVOICE

TO:	INVOICE NO.:	
	INVOICE DATE:	
	S/C NO.:	
FROM:	L/C NO.:	

TO:		L/C DATE:		
Marks and Numbers	Description of Goods	Quantity	Unit Price	Amount
Total:				

SAY TOTAL:

HUNAN PROVINCIAL LIGHT INDUSTRIAL PRODUCTS I/E CORP.

湖南轻工产品进出口公司

李明远

(Authorized Signature)

3、请根据以上资料缮制提单。（本题共 30 分）

（注：信用证的信息必须是修正后的正确信息）

Shipper		BILL OF LADING B/L NO.: 中国远洋运输公司 CHINA OCEAN SHIPPING ORIGINAL
Consignee or order		
Notify Party		
*Pre carriage by	*Place of Receipt	
Ocean Vessel Voy. No.	Port of Loading	

Port of discharge	*Final destination	Freight payable at	Number original Bs/L
Marks and Numbers	Number and kind of packages; Description	Gross weight	Measurement m³
TOTAL PACKAGES(IN WORDS)			
Freight and charges			
			Place and date of issue
			Signed for the Carrier SHANGHAI OCEAN SHIPPING CO., LTD. 丁浩

*Applicable only when document used as a Through Bill of Lading

4、请根据以上资料缮制汇票。（本题共 10 分）

（注：信用证的信息必须是修正后的正确信息）

BILL OF EXCHANGE

Drawn under _____

L/C No. _____

Dated _____

No. _____ **Exchange for** _____ **Changsha,**

China. _____ **At** _____ **sight of this FIRST of Exchange**
(Second of exchange being unpaid)

Pay to the order of _____

The sum of _____

To _____

HUNAN PROVINCIAL LIGHT INDUSTRIAL PRODUCTS I/E CORP.

湖南轻工产品进出口公司

李明远

(Authorized Signature)

(2) 实施条件

项目	基本实施条件	备注
场地	每个商务英语实训室配置 40 个操作台面和座位，每个实训室照明通风良好。	必备
设备	每个商务英语实训室配有 1 台服务器、40—50 台计算机，并安装 Office 办公软件，配置局域网。	必备
测评专家	每 40 名考生配备 1 名考评员。考评员要求具备至少二年以上从事国际贸易工作经验或二年以上外贸单证缮制实践教学指导经历。	必备

(3) 考核时量

考核时间：90 分钟

(4) 评分标准

模块总分	评价内容	配分		考核点	备注
岗位核心	职业素养与	职业素养 (6分)	2分	(1) 具备外贸从业人员基本素质，认真严谨、耐心细致、恪守信誉、实事求是、服从	在考试过程中不服从安排、

技能模块 项目二： 外贸单证 缮制 (总分 100 分，占总评 分的 50%)	操作规范 (10分)		安排，听从指挥、举止文明；	举止不得当者，记 0 分。	
		2分	具备对外贸合同及信用证信息甄别正误及修正能力、正确缮制单证能力，做到数据计算准确、信息填写正确、单据填写完整；	与上述能力及素养不符，扣 1-2 分。	
		2分	(3)具备正确规范操作外贸电商平台能力，具有对外贸产品筛选关键信息的能力，符合外贸行业对外贸电商运营等相关岗位需求。	与上述能力及素养不符，扣 1-2 分。	
		操作规范 (4分)	2分	(1) 具备使用办公设备和 Office 办公软件的能力，在考核过程中以及考核结束后，不私自更换电脑、不随意关闭或重启电脑，没征求监考老师同意不随意提前或推迟交卷；	若私自更换电脑、随意关闭或重启电脑，记 0 分。
			2分	(2) 能严格遵守企业 6S 管理要求（整理、整顿、清扫、清洁、素养、安全）。	若未遵守企业 6S 管理要求，记 0 分。
		作品 (90分)	信用证 审核 (16分)	2分	(1) 买卖双方的名称与地址是否有误；
	2分			(2) 品名、规格、数量、重量、单价是否有误；	
	2分			(3) 货物包装、体积是否有误；	
	2分			(4) 使用的贸易术语是否有误；	
	2分			(5) 合同金额和币种是否有误；	
	2分			(6) 合同中溢短装条款是否有误；	
	2分			(7) 唛头是否有误；	
	2分			(8) 起运港和目的港是否有误；	
	2分	(9) 分批装运和转运是否有误；			
2分	(10) 保险险别、保险金额是否有误；				
2分	(11) 最迟装运期是否有误；				
2分	(12) 汇票的付款期限是否有误；单据条款是否有误。				

商业发票缮制 (34分)	2分	(1) 进口商名称和地址：拼写准确无误；	商业发票缮制部分共 17 个考核点，每处计 2 分，未填、错填每处扣 2 分。拼写错误每 3 处扣 1 分。
	2分	(2) 商业发票号码：填写准确无误；	
	2分	(3) 商业发票开立日期：填写准确无误；	
	2分	(4) 合同号码：填写准确无误；	
	2分	(5) 信用证号码：填写准确无误；	
	2分	(6) 信用证日期：填写准确无误；	
	2分	(7) 运输路线装运地：填写准确无误；	
	2分	(8) 运输路线目的地：填写准确无误；	
	2分	(9) 价格术语：填写准确无误；	
	2分	(10) 货物唛头：填写准确无误；	
	2分	(11) 货物描述：品名拼写正确，规格信息填写准确无误；	
	2分	(12) 货物数量：填写准确无误；	
	2分	(13) 货物单价及单位：填写准确无误；	
	2分	(14) 货物金额：填写准确无误；	
	2分	(15) 货物数量总计：计算准确无误；	
	2分	(16) 货物金额总计：计算准确无误，货币名称正确；	
	2分	(17) 总金额大写：英文拼写正确。	
提单缮制 (30分)	2分	(1) 发货人条款：根据信用证中有关提单条款的规定进行正确的填写；	提单缮制部分共 15 个考核点，每处计 2 分，未填、错填每处扣 2 分。拼写错误每 3 处扣 1 分。
	2分	(2) 收货人条款：根据信用证中有关提单条款的规定进行正确的填写；	
	2分	(3) 通知人条款：根据信用证中有关提单条款的规定进行正确的填写；	
	2分	(4) 提单号码：填写准确无误；	

			2分	(5) 船名及船次: 填写准确无误;	
			2分	(6) 装货港: 填写准确无误;	
			2分	(7) 卸货港: 填写准确无误;	
			2分	(8) 运费支付地点: 填写准确无误;	
			2分	(9) 提单份数: 填写准确无误;	
			2分	(10) 唛头: 填写准确无误;	
			2分	(11) 货物描述条款: 包括货物的总称、包装的总数量等, 填写准确无误;	
			2分	(12) 毛重条款: 计算准确无误, 单位描述正确;	
			2分	(13) 体积条款: 计算准确无误, 单位描述正确;	
			2分	(14) 包装总数量: 填写准确无误;	
			2分	(15) 提单签发地点及日期: 填写准确无误。	
		汇票缮制 (10分)	1分	(1) 出票条款: 开证行完整名称, 拼写准确无误;	汇票缮制部分共10个考核点, 每处计1分, 未填、错填每处扣1分。拼写错误每3处扣1分。
			1分	(2) 信用证号码: 填写准确无误;	
			1分	(3) 信用证开证日期: 填写准确无误;	
			1分	(4) 汇票号码: 填写准确无误;	
			1分	(5) 汇票日期: 填写准确无误;	
			1分	(6) 汇票金额小写: 填写准确无误;	
			1分	(7) 汇款期限: 填写准确无误;	
			1分	(8) 收款人: 信用证下以议付行为收款人, 托收汇票下以托收行(出口地银行)为收款人; 信息完整无误, 拼写正确;	

			1分	(9) 金额及币种大写：币种与金额必须与信用证保持一致，拼写准确无误；	
			1分	(10) 付款人：信用证项下付款人为开证行或指定银行：信息完整无误，拼写正确。	

3.试题编号：2-2-3 信用证审核、单证缮制

(1) 任务描述

任务 1：信用证审核

熟悉 UCP600 相关条款；读懂外贸合同条款；读懂并审核 L/C 各条款；修改 L/C 中的问题条款。

注意：考试资料中的信用证为错误的信用证，考试中涉及到信用证的信息必须参考修改正确的信用证的信息，否则造成的制单错误将不计分。

任务 2：商业发票缮制

分析信用证中涉及商业发票缮制的相关条款；准确缮制商业发票；确保缮制的商业发票与信用证的条款一致。

任务 3：提单缮制

分析信用证的装运条款；准确缮制提单；确保缮制的提单与信用证的条款一致。

任务 4：汇票缮制

分析信用证中涉及汇票缮制的相关条款；准确缮制汇票；确保缮制的汇票与信用证的条款一致。

背景资料

1、出口方基本情况

Company	HUNAN PROVINCIAL LIGHT INDUSTRIAL PRODUCTS I/E CORP.
---------	--

Url	http://ccn.mofcom.gov.cn/923748
Office Address	NO. 4 EAST WUYI ROAD, CHANGSHA, HUNAN, CHINA
Zip code	410001
Phone	86-731-82287135
Fax	86-731-82287136
E-mail	hnqgyp_123@163.com

2、进口方基本情况

Company	NASEEB INTERNATIONAL CORP.
Url	http://www.naseebintl.com/
Office Address	1600 BRIMLEY ROAD, SCARBOROUGH, ONTARIO, CANADA
Tollfree	无
Phone	416-917-7344
Fax	416-292-9943

3、合同

销售合同

SALES CONTRACT

SELLER: HUNAN PROVINCIAL LIGHT INDUSTRIAL PRODUCTSNO.: HLIP-03726
I/E CORP. **DATE:** APR. 3, 2022
NO. 4 EAST WUYI ROAD, CHANGSHA, HUNAN, CHINA **SIGNED IN:** CHANGSHA

BUYER: NASEEB INTERNATIONAL CORP.
1600 BRIMLEY ROAD, SCARBOROUGH, ONTARIO, CANADA

This contract is made by and agreed between the BUYER and SELLER, in accordance with the terms and conditions stipulated below.

1. Commodity & Specification	2. Quantity	3. Unit Price & Trade Terms	4. Amount
CIF VANCOUVER			
FUXIA LEATHER PLATFORM SANDALS BIAN-1002	1,500 PAIRS	USD 27.40/PAIR	USD 41,100.00
Total:	1,500 PAIRS		USD 41,100.00

5. Total Value SAY U.S. DOLLARS FORTY ONE THOUSAND ONE HUNDRED ONLY.

6. Packing BIAN-1002: 12PAIRS/CARTON
TOTAL: 125 CARTONS

7. Shipping Marks VANCOUVER
TG503726
NO.1-125

8. Time of Shipment & means of Transportation TO BE EFFECTED NO LATER THAN THE END OF MAY 2022 FROM SHANGHAI TO VANCOUVER WITH PARTIAL SHIPMENT NOT ALLOWED AND TRANSSHIPMENT ALLOWED.

9. Port of Loading & Destination FROM: SHANGHAI
TO: VANCOUVER

10. Insurance THE SELLER SHALL COVER INSURANCE AGAINST ALL RISKS & WAR RISK FOR 110% OF THE TOTAL INVOICE VALUE AS PER THE RELEVANT OCEAN MARINE CARGO OF P.I.C.C. DATED 1/1/1981

11. Terms of Payment TO BE MADE BY SIGHT L/C

12. Remarks

The Buyer	The Seller
NASEEB INTERNATIONAL CORP.	HUNAN PROVINCIAL LIGHT INDUSTRIAL PRODUCTS I/E CORP.
(signature)	(signature)

4、信用证

27:	SEQUENCE OF TOTAL	1/1
40A:	FORM OF DOCUMENTARY CREDIT	REVOCABLE
20:	DOCUMENTARY CREDIT NUMBER	807705
31C:	DATE OF ISSUE	220413
31D:	DATE AND PLACE OF EXPIRY	220621 CHINA
50:	APPLICANT	
	NASEEB INTERNATIONAL CORP.	
	1600 BRIMLEY ROAD, SARBOROUH, ONTARIO, CANADA	

59: BENEFICIARY
HUNAN PROVINCIAL LIGHT INDUSTRIAL PRODUCTS I/F CORP.
NO. 4 EAST WUYI ROAD, CHANGSHA, HUNAN, CHINA

32B: AMOUNT USD 41,000.00

39B: CREDIT AMT NOT EXCEEDING

41D: AVAILABLE WITH BY ANY BANK IN CHINA

42C: DRAFTS AT AT SIGHT

42D: DRAWEE CITI BANK, ONTARIO BRANCH

43P: PARTIAL SHIPMENTS ALLOWED

43T: TRANSSHIPMENT ALLOWED

44A: LOADING ON BOARD SHANGHAI, CHINA

44B: FOR TRANSPORTATION TO SCARBOROUGH, CANADA

44C: LATEST DATE OF SHIPMENT 220531

45A: DESCRIPTION OF GOODS
1500 PAIRS FUXIA LEATHER PLATFORM SANDALS BIWN-1002
USD 27.40/PAIR CIF VANCOUVER

46A: DOCUMENTS REQUIRED
+SIGNED COMMERCIAL INVOICE IN TRIPLICATE.
+PACKING LIST IN TRIPLICATE.
+CERTIFICATE OF ORIGIN GSP CHINA FORM A, ISSUED BY THE CHAMBER OF
COMMERCE OR OTHER AUTHORITY DULY ENTITLED FOR THIS PURPOSE.
+FULL SET OF CLEAN ON BOARD OCEAN BILLS OF LADING, MADE OUT TO ORDER
OF SHIPPER AND BLANK ENDORSED AND MARKED "FREIGHT PREPAID" AND
NOTIFY APPLICANT.
+FULL SET OF NEGOTIABLE INSURANCE POLICY OR CERTIFICATE BLANK
ENDORSED FOR 110 PCT OF INVOICE VALUE COVERING ALL RISKS & WAR RISK.
+SHIPPING ADVICES MUST BE SENT TO APPLICANT ON THE DATE OF SHIPMENT
ADVISING SHIPPING MARKS, COMMODITY NAME, CARTON NUMBERS, TOTAL
GROSS WEIGHT, VESSEL NAME, BILL OF LADING NO., PORT OF LOADING,
DESTINATION, CONTRACT NO., INVOICE NO., LETTER OF CREDIT NO.

+COPY OF LETTER FROM BENEFICIARY TO OUR APPLICANT EVIDENCING A NON NEGOTIABLE BILL OF LADING TOGETHER WITH COPY OF OTHER DOCUMENTS WAS SENT DIRECTLY TO THEM AFTER ONE DAY FROM SHIPMENT DATE.

71B: CHARGES ALL BANKING CHARGES OUTSIDE CANADA ARE FOR ACCOUNT OF APPLICANT.

48: PERIOD FOR PRESENTATION DOCUMENTS MUST BE PRESENTED WITHIN 15 DAYS AFTER THE DATE OF SHIPMENT BUT WITHIN THE VALIDITY OF THE CREDIT.

5、相关资料

- (1) INVOICE NO.: TYH0076
- (2) INVOICE DATE: APRIL 23, 2022
- (3) PACKING

G. W.(KGS/CTN) N. W.(KGS/CTN) MEAS (CBM/CTN)

BIAN-1002: 12 10 0.8

PACKED IN 125 CARTONS

TOTAL TWO 40' CONTAINERS

- (4) VESSEL: HONGHE V. 188
- (5) B/L NO.: JUC112709
- (6) B/L DATE: MAY 08, 2022
- (7) POLICY NO.: FW160501
- (8) REFERENCE NO.: 20220429

抽考试题

1、请根据考试资料中的合同 3 审核错误的信用证 4，指出不符之处并修正。

(本题共 16 分)

- 1. _____
- 2. _____
- 3. _____

4. _____
5. _____
6. _____
7. _____
8. _____

2、请根据以上资料缮制商业发票。（本题共 34 分）

（注：信用证的信息必须是修正后的正确信息）

湖南轻工产品进出口公司

Hunan Provincial Light Industrial Products I/E Corp.

No. 4 East Wuyi Road, Changsha, Hunan, China

TEL: 86-731-82287135 FAX: 86-731-82287136

商业发票

COMMERCIAL INVOICE

TO:		INVOICE NO.:		
		INVOICE DATE:		
		S/C NO.:		
FROM:		L/C NO.:		
TO:		L/C DATE:		
Marks and Numbers	Description of Goods	Quantity	Unit Price	Amount
Total:				

SAY TOTAL:

HUNAN PROVINCIAL LIGHT INDUSTRIAL PRODUCTS I/E CORP.

湖南轻工产品进出口公司

李明远

(Authorized Signature)

3、请根据以上资料缮制提单。(本题共 30 分)

(注：信用证的信息必须是修正后的正确信息)

Shipper		BILL OF LADING B/L NO.: 中国远洋运输公司 CHINA OCEAN SHIPPING ORIGINAL	
Consignee or order			
Notify Party			
*Pre carriage by	*Place of Receipt		
Ocean Vessel Voy. No.	Port of Loading		
Port of discharge	*Final destination	Freight payable at	Number original Bs/L
Marks and Numbers	Number and kind of packages; Description	Gross weight	Measurement m³
TOTAL PACKAGES(IN WORDS)			

Freight and charges	Place and date of issue
	Signed for the Carrier
	SHANGHAI OCEAN SHIPPING CO., LTD. 丁浩

*Applicable only when document used as a Through Bill of Lading

4、请根据以上资料缮制汇票。（本题共 10 分）

（注：信用证的信息必须是修正后的正确信息）

BILL OF EXCHANGE

Drawn under _____

L/C No. _____

Dated _____

No. _____ **Exchange for** _____ **Changsha,**

China. _____ **At** _____ **sight of this FIRST of**

Exchange (Second of exchange being unpaid)

Pay to the order of _____

The sum of _____

To _____

HUNAN PROVINCIAL LIGHT INDUSTRIAL PRODUCTS I/E CORP.

湖南轻工产品进出口公司

李明选

(Authorized Signature)

(2) 实施条件

项目	基本实施条件	备注
场地	每个商务英语实训室配置 40 个操作台面和座位，每个实训室照明通风良好。	必备
设备	每个商务英语实训室配有 1 台服务器、40—50 台计算机，并安装 Office 办公软件，配置局域网。	必备
测评专家	每 40 名考生配备 1 名考评员。考评员要求具备至少二年以上从事国际贸易工作经验或二年以上外贸单证缮制实践教学指导经历。	必备

(3) 考核时量

考核时间：90 分钟

(4) 评分标准

模块总分	评价内容	配分		考核点	备注
岗位核心技能模块项目二：外贸单证缮制 (总分 100 分，占总评分的 50%)	职业素养与操作规范 (10 分)	职业素养 (6 分)	2 分	(1) 具备外贸从业人员基本素质，认真严谨、耐心细致、恪守信誉、实事求是、服从安排，听从指挥、举止文明；	在考试过程中不服从安排、举止不得当者，记 0 分。
			2 分	具备对外贸合同及信用证信息甄别正误及修正能力、正确缮制单证能力，做到数据计算准确、信息填写正确、单据填写完整；	与所述能力及素养不符，扣 1-2 分。
			2 分	(3) 具备正确规范操作外贸电商平台能力，具有对外贸产品筛选关键信息的能力，符合外贸行业对外贸电商运营等相关岗位需求。	与所述能力及素养不符，扣 1-2 分。
		操作规范 (4 分)	2 分	(1) 具备使用办公设备和 Office 办公软件的能力，在考核过程中以及考核结束后，不私自更换电脑、不随意关闭或重启电脑，没征求监考老师同意不随意提前或推迟交卷；	若私自更换电脑、随意关闭或重启电脑，记 0 分。

			2分	(2) 能严格遵守企业 6S 管理要求 (整理、整顿、清扫、清洁、素养、安全)。	若未遵守企业 6S 管理要求, 记 0 分。	
作品 (90分)	信用证 审核 (16分)		2分	(1) 买卖双方的名称与地址是否有误;	信用证审核共 12 个考核点, 有 8 处错误, 每处 2 分, 找出错误计 1 分, 修正错误计 1 分。	
			2分	(2) 品名、规格、数量、重量、单价是否有误;		
			2分	(3) 货物包装、体积是否有误;		
			2分	(4) 使用的贸易术语是否有误;		
			2分	(5) 合同金额和币种是否有误;		
			2分	(6) 合同中溢短装条款是否有误;		
			2分	(7) 唛头是否有误;		
			2分	(8) 起运港和目的港是否有误;		
			2分	(9) 分批装运和转运是否有误;		
			2分	(10) 保险险别、保险金额是否有误;		
			2分	(11) 最迟装运期是否有误;		
			2分	(12) 汇票的付款期限是否有误; 单据条款是否有误。		
		商业发票 缮制 (34分)		2分	(1) 进口商名称和地址: 拼写准确无误;	商业发票缮制部分共 17 个考核点, 每处计 2 分, 未填、错填每处扣 2 分。拼写错误每 3 处扣 1 分。
				2分	(2) 商业发票号码: 填写准确无误;	
				2分	(3) 商业发票开立日期: 填写准确无误;	
				2分	(4) 合同号码: 填写准确无误;	
				2分	(5) 信用证号码: 填写准确无误;	
				2分	(6) 信用证日期: 填写准确无误;	
				2分	(7) 运输路线装运地: 填写准确无误;	
				2分	(8) 运输路线目的地: 填写准确无误;	
			2分	(9) 价格术语: 填写准确无误;		
			2分	(10) 货物唛头: 填写准确无误;		

			2分	(11) 货物描述：品名拼写正确，规格信息填写准确无误；	
			2分	(12) 货物数量：填写准确无误；	
			2分	(13) 货物单价及单位：填写准确无误；	
			2分	(14) 货物金额：填写准确无误；	
			2分	(15) 货物数量总计：计算准确无误；	
			2分	(16) 货物金额总计：计算准确无误，货币名称正确；	
			2分	(17) 总金额大写：英文拼写正确。	
		提单缮制 (30分)	2分	(1) 发货人条款：根据信用证中有关提单条款的规定进行正确的填写；	提单缮制部分共15个考核点，每处计2分，未填、错填每处扣2分。拼写错误每3处扣1分。
			2分	(2) 收货人条款：根据信用证中有关提单条款的规定进行正确的填写；	
			2分	(3) 通知人条款：根据信用证中有关提单条款的规定进行正确的填写；	
			2分	(4) 提单号码：填写准确无误；	
			2分	(5) 船名及船次：填写准确无误；	
			2分	(6) 装货港：填写准确无误；	
			2分	(7) 卸货港：填写准确无误；	
			2分	(8) 运费支付地点：填写准确无误；	
			2分	(9) 提单份数：填写准确无误；	
			2分	(10) 唛头：填写准确无误；	
			2分	(11) 货物描述条款：包括货物的总称、包装的总数量等，填写准确无误；	
			2分	(12) 毛重条款：计算准确无误，单位描述正确；	

			2分	(13) 体积条款: 计算准确无误, 单位描述正确;	
			2分	(14) 包装总数量: 填写准确无误;	
			2分	(15) 提单签发地点及日期: 填写准确无误。	
		汇票缮制 (10分)	1分	(1) 出票条款: 开证行完整名称, 拼写准确无误;	汇票缮制部分共 10 个考核点, 每处计 1 分, 未填、错填每处扣 1 分。拼写错误每 3 处扣 1 分。
			1分	(2) 信用证号码: 填写准确无误;	
			1分	(3) 信用证开证日期: 填写准确无误;	
			1分	(4) 汇票号码: 填写准确无误;	
			1分	(5) 汇票日期: 填写准确无误;	
			1分	(6) 汇票金额小写: 填写准确无误;	
			1分	(7) 汇款期限: 填写准确无误;	
			1分	(8) 受款人: 信用证下以议付行为受款人, 托收汇票下以托收行(出口地银行)为受款人: 信息完整无误, 拼写正确;	
			1分	(9) 金额及币种大写: 币种与金额必须与信用证保持一致, 拼写准确无误;	
			1分	(10) 付款人: 信用证项下付款人为开证行或指定银行: 信息完整无误, 拼写正确。	

4. 试题编号: 2-2-4 信用证审核、单证缮制

(1) 任务描述

任务 1: 信用证审核

熟悉 UCP600 相关条款; 读懂外贸合同条款; 读懂并审核 L/C 各条款; 修改 L/C 中的问题条款。

注意: 考试资料中的信用证为错误的信用证, 考试中涉及到信用

证的信息必须参考修改正确的信用证的信息，否则造成的制单错误将不计分。

任务 2：商业发票缮制

分析信用证中涉及商业发票缮制的相关条款；准确缮制商业发票；确保缮制的商业发票与信用证的条款一致。

任务 3：提单缮制

分析信用证的装运条款；准确缮制提单；确保缮制的提单与信用证的条款一致。

任务 4：汇票缮制

分析信用证中涉及汇票缮制的相关条款；准确缮制汇票；确保缮制的汇票与信用证的条款一致。

背景资料

1、出口方基本情况

Company	HUNAN CEREALS, OILS AND FOODSTUFFS IMP. & EXP. GROUP CORP. LTD.
Url	http://www.hunancof.com/
Office Address	NO. 2 ZHUYUAN RD, CHANGSHA, HUNAN, CHINA
Zip code	410011
Phone	86-731-82280772
Fax	86-731-82289135
E-mail	Lixiang55@hunancof.com

2、进口方基本情况

Company	WHOLE FOODS MARKET
Url	http://www.wholefoodsmarket.com/
Office Address	105 MASON STREET, AUSTIN TE 15002, U.S.A.

Tollfree	无
Phone	001-214-982 1562
Fax	001-214-982 1569

3、合同

销售合同 SALES CONTRACT

SELLER: HUNAN CEREALS, OILS AND FOODSTUFFS IMP. & EXP. **NO.:** HCOF-11108
GROUP CORP. LTD. **DATE:** JAN. 25,2022
NO. 2 ZHUYUAN RD, CHANGSHA, HUNAN, CHINA **SIGNED IN:** CHANGSHA
BUYER: WHOLE FOODS MARKET
105 MASON STREET, AUSTIN TE 15002, U.S.A.

This contract is made by and agreed between the BUYER and SELLER, in accordance with the terms and conditions stipulated below.

1. Commodity & Specification	2. Quantity	3. Unit Price & Trade Terms	4. Amount
CIF NEW YORK			
SUSHI RICE SUSHI RICE MOISTURE: MAX. 14.5% FOREIGN MATTER: MAX. 1%, BROKEN: MAX. 5%	10,000 BAGS	USD 4.75/BAG	USD 47,500.00
Total:	10,000 BAGS		USD 47,500.00

With 10% More or less of shipment allowed at the sellers' option

5. Total Value SAY U.S. DOLLARS FORTY SEVEN THOUSAND AND FIVE HUNDRED ONLY.

6. Packing PACKED IN 10BAGS/CARTON
PACKED IN 1,000 CARTONS

7. Shipping Marks N/M

8. Time of Shipment & means of Transportation TO BE EFFECTED BEFORE THE END OF MARCH 2022 FROM GUANGZHOU TO NEW YORK WITH PARTIAL SHIPMENT NOT ALLOWED AND TRANSSHIPMENT ALLOWED.

9. Port of Loading & Destination FROM: GUANGZHOU
TO: NEW YORK

10. Insurance THE SELLER SHALL COVER INSURANCE AGAINST ALL RISKS & WAR RISK FOR 110% OF THE TOTAL INVOICE VALUE AS PER THE RELEVANT OCEAN MARINE CARGO OF P.I.C.C. DATED 1/1/1981

11. Terms of Payment TO BE MADE BY SIGHT L/C

12. Remarks

The Buyer	The Seller
WHOLE FOODS MARKET	HUNAN CEREALS, OILS AND FOODSTUFFS IMP. & EXP. GROUP CORP. LTD.
(signature)	(signature)

4、信用证

27:	SEQUENCE OF TOTAL	1/1
40A:	FORM OF DOCUMENTARY CREDIT	REVOCABLE
20:	DOCUMENTARY CREDIT NUMBER	87308/03
31C:	DATE OF ISSUE	220220
31D:	DATE AND PLACE OF EXPIRY	220421CHINA
50:	APPLICANT WHOLE FOODS MARKET 105 MASON STREET, AUSTIN TE 15002, U.S.A.	
59:	BENEFICIARY HUNAN OILS FOODSTUFFS EXPORT GROUP NO. 2 ZHUYUAN RD, CHANGSHA, HUNAN, CHINA	
32B:	AMOUNT	USD 47,500.00
39B:	CREDIT AMT	NOT EXCEEDING
41D:	AVAILABLE WITH BY	ANY BANK IN CHINA
42C:	DRAFTS AT	60 DAYS AFTER SIGHT
42D:	DRAWEE	HSBC AUSTIN BRANCH
43P:	PARTIAL SHIPMENTS	ALLOWED
43T:	TRANSSHIPMENT	NOT ALLOWED
44A:	LOADING ON BOARD	GUANGZHOU, CHINA
44B:	FOR TRANSPORTATION TO	SYDNEY, AUSTRALIA
44C:	LATEST DATE OF SHIPMENT	220331

45A: DESCRIPTION OF GOODS
1000 MT SUSHI RICE
MOISTURE: MAX. 14.5%
FOREIGN MATTER: MAX. 1%
BROKEN: MAX. 5%
USD 4.75/BAG FOB NEW YORK

46A: DOCUMENTS REQUIRED

+SIGNED COMMERCIAL INVOICE IN TRIPLICATE.

+PACKING LIST IN TRIPLICATE.

+CERTIFICATE OF ORIGIN GSP CHINA FORM A, ISSUED BY THE CHAMBER OF COMMERCE OR OTHER AUTHORITY DULY ENTITLED FOR THIS PURPOSE.

+FULL SET OF CLEAN ON BOARD OCEAN BILLS OF LADING, MADE OUT TO ORDER OF SHIPPER AND BLANK ENDORSED AND MARKED "FREIGHT PREPAID" AND NOTIFY APPLICANT.

+FULL SET OF NEGOTIABLE INSURANCE POLICY OR CERTIFICATE BLANK ENDORSED FOR 110 PCT OF INVOICE VALUE COVERING ALL RISKS & WAR RISK.

+SHIPPING ADVICES MUST BE SENT TO APPLICANT ON THE DATE OF SHIPMENT ADVISING SHIPPING MARKS, COMMODITY NAME, CARTON NUMBERS, TOTAL GROSS WEIGHT, VESSEL NAME, BILL OF LADING NO., PORT OF LOADING, DESTINATION, CONTRACT NO., INVOICE NO., LETTER OF CREDIT NO.

+COPY OF LETTER FROM BENEFICIARY TO OUR APPLICANT EVIDENCING A NON NEGOTIABLE BILL OF LADING TOGETHER WITH COPY OF OTHER DOCUMENTS WAS SENT DIRECTLY TO THEM AFTER ONE DAY FROM SHIPMENT DATE.

71B: CHARGES ALL BANKING CHARGES OUTSIDE U.S.A. ARE FOR ACCOUNT OF BENEFICIARY.

48: PERIOD FOR PRESENTATION DOCUMENTS MUST BE PRESENTED WITHIN 15 DAYS AFTER THE DATE OF SHIPMENT BUT WITHIN THE VALIDITY OF THE CREDIT.

5、相关资料

(1) INVOICE NO.: HNLY83865

(2) INVOICE DATE: FEBRUARY 28, 2022

(3) PACKING

G. W.(KGS/CTN)	N. W.(KGS/CTN)	MEAS (CBM/CTN)
50	49	0.01

PACKED IN 1,000 CARTONS

TOTAL TWO 40' CONTAINERS

- (4) VESSEL: KAI XUAN 376T
- (5) B/L NO.: COCO5674392
- (6) B/L DATE: MARCH 15, 2022
- (7) POLICY NO.: QR156715
- (8) REFERENCE NO.: 20220110

抽考试题

1、请根据考试资料中的合同 3 审核错误的信用证 4，指出不符之处并修正。

(本题共 16 分)

- 1. _____
- 2. _____
- 3. _____
- 4. _____
- 5. _____
- 6. _____
- 7. _____
- 8. _____

2、请根据以上资料缮制商业发票。(本题共 34 分)

(注：信用证的信息必须是修正后的正确信息)

湖南粮油食品进出口集团公司

Hunan Cereals, Oils and Foodstuffs Imp. & Exp. Group Corp. Ltd.

No. 2 Zhuyuan RD, Changsha, Hunan, China

TEL: 86-731-82280772 FAX: 86-731-82289135

商业发票

COMMERCIAL INVOICE

TO:		INVOICE NO.:		
		INVOICE DATE:		
		S/C NO.:		
FROM:		L/C NO.:		
TO:		L/C DATE:		
Marks and Numbers	Description of Goods	Quantity	Unit Price	Amount
Total:				

SAY TOTAL:

HUNAN CEREALS, OILS AND FOODSTUFFS IMP. & EXP. GROUP CORP. LTD.

**湖南粮油食品进出口集团公司
王伶俐**

(Authorised Signature)

3、请根据以上资料缮制提单。（本题共 30 分）

（注：信用证的信息必须是修正后的正确信息）

Shipper
Consignee or order

BILL OF LADING

B/L NO.:

Notify Party		中国远洋运输公司	
*Pre carriage by	*Place of Receipt	CHINA OCEAN SHIPPING	
Ocean Vessel Voy. No.	Port of Loading	ORIGINAL	
Port of discharge	*Final destination	Freight payable at	Number original Bs/L
Marks and Numbers	Number and kind of packages; Description	Gross weight	Measurement m³
TOTAL PACKAGES(IN WORDS)			
Freight and charges			
			Place and date of issue
			Signed for the Carrier GUANGZHOU OCEAN SHIPPING CO., LTD. 凌风

*Applicable only when document used as a Through Bill of Lading

4、请根据以上资料缮制汇票。（本题共 10 分）

（注：信用证的信息必须是修正后的正确信息）

BILL OF EXCHANGE

Drawn under _____

L/C No. _____

Dated _____

No. _____ Exchange for _____

Changsha, China. _____ At _____ sight of this FIRST of

Exchange (Second of exchange being unpaid)

Pay to the order of _____

The sum of _____

To _____

HUNAN CEREALS, OILS AND FOODSTUFFS IMP. & EXP. GROUP CORP. LTD.

湖南粮油食品进出口集团公司

王伶俐

(Authorized Signature)

(2) 实施条件

项目	基本实施条件	备注
场地	每个商务英语实训室配置 40 个操作台面和座位，每个实训室照明通风良好。	必备
设备	每个商务英语实训室配有 1 台服务器、40—50 台计算机，并安装 Office 办公软件，配置局域网。	必备
测评专家	每 40 名考生配备 1 名考评员。考评员要求具备至少二年以上从事国际贸易工作经验或二年以上外贸单证缮制实践教学指导经历。	必备

(3) 考核时量 _____

考核时间：90 分钟

(4) 评分标准

模块总分	评价内容	配分		考核点	备注
岗位核心技能模块项目二：外贸单证缮制 (总分 100 分，占总评分的 50%)	职业素养与操作规范 (10 分)	职业素养 (6 分)	2 分	(1) 具备外贸从业人员基本素质，认真严谨、耐心细致、恪守信誉、实事求是、服从安排，听从指挥、举止文明；	在考试过程中不服从安排、举止不得当者，记 0 分。
			2 分	具备对外贸合同及信用证信息甄别正误及修正能力、正确缮制单证能力，做到数据计算准确、信息填写正确、单据填写完整；	与上述能力及素养不符，扣 1-2 分。
			2 分	(3) 具备正确规范操作外贸电商平台能力，具有对外贸产品筛选关键信息的能力，符合外贸行业对外贸电商运营等相关岗位需求。	与上述能力及素养不符，扣 1-2 分。
		操作规范 (4 分)	2 分	(1) 具备使用办公设备和 Office 办公软件的能力，在考核过程中以及考核结束后，不私自更换电脑、不随意关闭或重启电脑，没征求监考老师同意不随意提前或推迟交卷；	若私自更换电脑、随意关闭或重启电脑，记 0 分。
			2 分	(2) 能严格遵守企业 6S 管理要求（整理、整顿、清扫、清洁、素养、安全）。	若未遵守企业 6S 管理要求，记 0 分。
			信用证审核 (16 分)		信用证审核共 12 个考核点，有 8 处错误，每处 2 分，找出错误计 1 分，修正错误计 1 分。
	2 分	(1) 买卖双方的名称与地址是否有误；			
	2 分	(2) 品名、规格、数量、重量、单价是否有误；			
	2 分	(3) 货物包装、体积是否有误；			
	2 分	(4) 使用的贸易术语是否有误；			
2 分	(5) 合同金额和币种是否有误；				
2 分	(6) 合同中溢短装条款是否有误；				
2 分	(7) 唛头是否有误；				

			2分	(8) 起运港和目的港是否有误;	
			2分	(9) 分批装运和转运是否有误;	
			2分	(10) 保险险别、保险金额是否有误;	
			2分	(11) 最迟装运期是否有误;	
			2分	(12) 汇票的付款期限是否有误; 单据条款是否有误。	
		商业发票缮制 (34分)	2分	(1) 进口商名称和地址: 拼写准确无误;	商业发票缮制部分共 17 个考核点, 每处计 2 分, 未填、错填每处扣 2 分。拼写错误每 3 处扣 1 分。
			2分	(2) 商业发票号码: 填写准确无误;	
			2分	(3) 商业发票开立日期: 填写准确无误;	
			2分	(4) 合同号码: 填写准确无误;	
			2分	(5) 信用证号码: 填写准确无误;	
			2分	(6) 信用证日期: 填写准确无误;	
			2分	(7) 运输路线装运地: 填写准确无误;	
			2分	(8) 运输路线目的地: 填写准确无误;	
			2分	(9) 价格术语: 填写准确无误;	
			2分	(10) 货物唛头: 填写准确无误;	
			2分	(11) 货物描述: 品名拼写正确, 规格信息填写准确无误;	
			2分	(12) 货物数量: 填写准确无误;	
			2分	(13) 货物单价及单位: 填写准确无误;	
			2分	(14) 货物金额: 填写准确无误;	
			2分	(15) 货物数量总计: 计算准确无误;	
			2分	(16) 货物金额总计: 计算准确无误, 货币名称正确;	
			2分	(17) 总金额大写: 英文拼写正确。	
		提单	2分	(1) 发货人条款: 根据信用证中有关提单	提单缮制部分

		缮制 (30分)		条款的规定进行正确的填写；	共 15 个考核点，每处计 2 分，未填、错填每处扣 2 分。拼写错误每 3 处扣 1 分。
			2分	(2) 收货人条款：根据信用证中有关提单条款的规定进行正确的填写；	
			2分	(3) 通知人条款：根据信用证中有关提单条款的规定进行正确的填写；	
			2分	(4) 提单号码：填写准确无误；	
			2分	(5) 船名及船次：填写准确无误；	
			2分	(6) 装货港：填写准确无误；	
			2分	(7) 卸货港：填写准确无误；	
			2分	(8) 运费支付地点：填写准确无误；	
			2分	(9) 提单份数：填写准确无误；	
			2分	(10) 唛头：填写准确无误；	
			2分	(11) 货物描述条款：包括货物的总称、包装的总数量等，填写准确无误；	
			2分	(12) 毛重条款：计算准确无误，单位描述正确；	
			2分	(13) 体积条款：计算准确无误，单位描述正确；	
			2分	(14) 包装总数量：填写准确无误；	
			2分	(15) 提单签发地点及日期：填写准确无误。	
		汇票 缮制 (10分)	1分	(1) 出票条款：开证行完整名称，拼写准确无误；	汇票缮制部分共 10 个考核点，每处计 1 分，未填、错填每处扣 1 分。拼写错误每 3 处扣 1 分。
			1分	(2) 信用证号码：填写准确无误；	
			1分	(3) 信用证开证日期：填写准确无误；	
			1分	(4) 汇票号码：填写准确无误；	

			1分	(5) 汇票日期：填写准确无误；	
			1分	(6) 汇票金额小写：填写准确无误；	
			1分	(7) 汇款期限：填写准确无误；	
			1分	(8) 受款人：信用证下以议付行为受款人，托收汇票下以托收行（出口地银行）为受款人：信息完整无误，拼写正确；	
			1分	(9) 金额及币种大写：币种与金额必须与信用证保持一致，拼写准确无误；	
			1分	(10) 付款人：信用证项下付款人为开证行或指定银行：信息完整无误，拼写正确。	

5. 试题编号：2-2-5 信用证审核、单证缮制

(1) 任务描述

任务 1：信用证审核

熟悉 UCP600 相关条款；读懂外贸合同条款；读懂并审核 L/C 各条款；修改 L/C 中的问题条款。

注意：考试资料中的信用证为错误的信用证，考试中涉及到信用证的信息必须参考修改正确的信用证的信息，否则造成的制单错误将不计分。

任务 2：商业发票缮制

分析信用证中涉及商业发票缮制的相关条款；准确缮制商业发票；确保缮制的商业发票与信用证的条款一致。

任务 3：提单缮制

分析信用证的装运条款；准确缮制提单；确保缮制的提单与信用证的条款一致。

任务 4：汇票缮制

分析信用证中涉及汇票缮制的相关条款；准确缮制汇票；确保缮制的汇票与信用证的条款一致。

背景资料

1、出口方基本情况

Company	BROAD AIR QUALITY TECHNOLOGY GROUP
Url	http://www.broad.com:8089/english/
Office Address	YUANDA TOWN, YUANDA 3RD ROAD, CHANGSHA, HUNAN, CHINA
Zip code	410138
Phone	86-731-84086688
Fax	86-731-84610087
E-mail	international@broad.net

2、进口方基本情况

Company	ONNINEN GROUP
Url	http://www.onninen.com
Office Address	MITTALINJA 1, FI-01260 VANTAA, FINLAND
Tollfree	无
Phone	+358 (0)204 85 5111
Fax:	+358 (0)204 85 5500

3、合同

销售合同

SALES CONTRACT

SELLER: BROAD AIR QUALITY TECHNOLOGY GROUP
YUANDA TOWN, YUANDA 3RD ROAD,
CHANGSHA, HUNAN, CHINA

NO.: BR1003692
DATE: JUNE 20, 2022
SIGNED IN: CHANGSHA

BUYER: ONNINEN GROUP

MITTALINJA 1, FI-01260 VANTAA, FINLAND

This contract is made by and agreed between the BUYER and SELLER, in accordance with the terms and conditions stipulated below.

1. Commodity & Specification	2. Quantity	3. Unit Price & Trade Terms	4. Amount
CIF VARDO			
TWO-WAY MOTOR VALVE BVS20-2-16 VALVE(20 MM)	510 PCS	USD 198/PC	USD 100,980.00
BVS125-2-16 VALVE(125 MM)	610 PCS	USD 328/PC	USD 200,080.00
Total:	1,120 PCS		USD 301,060.00

5. Total Value SAY U.S. DOLLARS THREE HUNDRED AND ONE THOUSAND SIXTY ONLY.

6. Packing 1PC/BOX
PACKED IN 1,120 BOXES

7. Shipping Marks VARDO
BR1003692
NO.1-1120

8. Time of Shipment & means of Transportation TO BE EFFECTED BEFORE THE END OF JULY 2022 FROM SHANGHAI TO VARDO WITH PARTIAL SHIPMENT AND TRANSSHIPMENT NOT ALLOWED.

9. Port of Loading & Destination FROM: SHANGHAI
TO: VARDO

10. Insurance THE SELLER SHALL COVER INSURANCE AGAINST ALL RISKS & WAR RISK FOR 110% OF THE TOTAL INVOICE VALUE AS PER THE RELEVANT OCEAN MARINE CARGO OF P.I.C.C. DATED 1/1/1981

11. Terms of Payment TO BE MADE BY SIGHT L/C

12. Remarks

The Buyer

The Seller

ONNINEN GROUP

BROAD AIR QUALITY TECHNOLOGY
GROUP

(signature)

(signature)

4、信用证

27: SEQUENCE OF TOTAL 1/1

40A: FORM OF DOCUMENTARY CREDIT REVOCABLE

20:	DOCUMENTARY CREDIT NUMBER	HAND1006/423
31C:	DATE OF ISSUE	220701
31D:	DATE AND PLACE OF EXPIRY	220821 FINLAND
50:	APPLICANT	
	ONNINEN GROUP	
	MITTALINJA 1, FI-01260 VANTAA, FINLAND	
59:	BENEFICIARY	
	BROAD AIR QUALITY TECHNOLOGY GROUP	
	YUANDA TOWN, YUANDA 3RD ROAD, LIUYANG, HUNAN, CHINA	
32B:	AMOUNT	USD 301,060.00
39B:	CREDIT AMT	NOT EXCEEDING
41D:	AVAILABLE WITH BY	ANY BANK IN CHINA
42C:	DRAFTS AT	90 DAYS AFTER SIGHT
42D:	DRAWEE	MERITA BANK HELSINKI BRANCH
43P:	PARTIAL SHIPMENTS	ALLOWED
43T:	TRANSSHIPMENT	NOT ALLOWED
44A:	LOADING ON BOARD	SHANGHAI, CHINA
44B:	FOR TRANSPORTATION TO	VARDO, FINLAND
44C:	LATEST DATE OF SHIPMENT	220731
45A:	DESCRIPTION OF GOODS	
	510 PCS TWO-WAY MOTOR VALVE BVS20-2-16 VALVE (20MM)	
	USD 198/PC CIF VARGO	
	610 PCS TWO-WAY MOTOR VALVE BVS125-2-16 VALVE (125MM)	
	USD 328/ PC CIF VARGO	
46A:	DOCUMENTS REQUIRED	
	+SIGNED COMMERCIAL INVOICE IN TRIPLICATE.	
	+PACKING LIST IN TRIPLICATE.	
	+CERTIFICATE OF ORIGIN GSP CHINA FORM A, ISSUED BY THE CHAMBER OF COMMERCE OR OTHER AUTHORITY DULY ENTITLED FOR THIS PURPOSE.	
	+FULL SET OF CLEAN ON BOARD OCEAN BILLS OF LADING, MADE OUT TO ORDER OF SHIPPER AND BLANK ENDORSED AND MARKED "FREIGHT PREPAID" AND NOTIFY APPLICANT.	

+FULL SET OF NEGOTIABLE INSURANCE POLICY OR CERTIFICATE BLANK ENDORSED FOR 110 PCT OF INVOICE VALUE COVERING ALL RISKS AND WAR RISK.

+SHIPPING ADVICES MUST BE SENT TO APPLICANT ON THE DATE OF SHIPMENT ADVISING SHIPPING MARKS, COMMODITY NAME, CARTON NUMBERS, TOTAL GROSS WEIGHT, VESSEL NAME, BILL OF LADING NO., PORT OF LOADING, DESTINATION, CONTRACT NO., INVOICE NO., LETTER OF CREDIT NO.

+COPY OF LETTER FROM BENEFICIARY TO OUR APPLICANT EVIDENCING A NON NEGOTIABLE BILL OF LADING TOGETHER WITH COPY OF OTHER DOCUMENTS WAS SENT DIRECTLY TO THEM AFTER ONE DAY FROM SHIPMENT DATE.

71B: CHARGES ALL BANKING CHARGES OUTSIDE FINLAND ARE FOR ACCOUNT OF APPLICANT.

48: PERIOD FOR PRESENTATION WITHIN 15 DAYS AFTER THE DATE OF SHIPMENT BUT WITHIN THE VALIDITY OF THE CREDIT.

5、相关资料

(1) INVOICE NO.: BR0102331

(2) INVOICE DATE: JUNE 25, 2022

(3) PACKING

G. W.: 26 KGS/BOX

N. W.: 22 KGS/BOX

MEAS: 0.2 CBM/BOX

PACKED IN 1,120 BOXES

TOTAL SEVEN 20' CONTAINERS

(4) VESSEL: NANGXING V. 086

(5) B/L NO.: COCS0511861

(6) B/L DATE: JULY 20, 2022

(7) POLICY NO.: BR160720

(8) REFERENCE NO.: 2006879-09

抽考试题

1、请根据考试资料中的合同 3 审核错误的信用证 4，指出不符之处并修正。

(本题共 16 分)

1. _____
2. _____
3. _____
4. _____
5. _____
6. _____
7. _____
8. _____

2、请根据以上资料缮制商业发票。(本题共 34 分)

(注：信用证的信息必须是修正后的正确信息)

远大集团

Broad Air Quality Technology Group

Yunda Town, Yuanda 3rd Road, Changsha, Hunan, China

TEL: 86-731-84086688 FAX: 86-731-84610087

商业发票

COMMERCIAL INVOICE

TO:		INVOICE NO.:		
		INVOICE DATE:		
		S/C NO.:		
FROM:		L/C NO.:		
TO:		L/C DATE:		
Marks and Numbers	Description of Goods	Quantity	Unit Price	Amount

TOTAL PACKAGES(IN WORDS)		
Freight and charges		
		Place and date of issue
		Signed for the Carrier SHANGHAI OCEAN SHIPPING CO., LTD. 丁浩

*Applicable only when document used as a Through Bill of Lading

4、请根据以上资料缮制汇票。（本题共 10 分）

（注：信用证的信息必须是修正后的正确信息）

BILL OF EXCHANGE

Drawn under _____

L/C No. _____

Dated _____

No. _____ **Exchange for** _____ **Changsha, China.**

_____ **At** _____ **sight of this FIRST of Exchange (Second of exchange being unpaid)**

Pay to the order of _____

The sum of _____

To _____

(2) 实施条件

项目	基本实施条件	备注
场地	每个商务英语实训室配置 40 个操作台面和座位，每个实训室照明通风良好。	必备
设备	每个商务英语实训室配有 1 台服务器、40—50 台计算机，并安装 Office 办公软件，配置局域网。	必备
测评专家	每 40 名考生配备 1 名考评员。考评员要求具备至少二年以上从事国际贸易工作经验或二年以上外贸单证缮制实践教学指导经历。	必备

(3) 考核时量

考核时间：90 分钟

(4) 评分标准

模块总分	评价内容	配分		考核点	备注
岗位核心技能模块项目二：外贸单证缮制（总分 100 分，占总评	职业素养与操作规范（10 分）	职业素养（6 分）	2 分	(1) 具备外贸从业人员基本素质，认真严谨、耐心细致、恪守信誉、实事求是、服从安排，听从指挥、举止文明；	在考试过程中不服从安排、举止不得当者，记 0 分。
			2 分	具备对外贸合同及信用证信息甄别正误及修正能力、正确缮制单证能力，做到数据计算准确、信息填写正确、单据填写完整；	

分的 50%)			2分	(3)具备正确规范操作外贸电商平台能力,具有对外贸产品筛选关键信息的能力,符合外贸行业对外贸电商运营等相关岗位需求。	与所述能力及素养不符,扣1-2分。
		操作规范 (4分)	2分	(1)具备使用办公设备和 Office 办公软件的能力,在考核过程中以及考核结束后,不私自更换电脑、不随意关闭或重启电脑,没征求监考老师同意不随意提前或推迟交卷;	若私自更换电脑、随意关闭或重启电脑,记0分。
			2分	(2)能严格遵守企业 6S 管理要求(整理、整顿、清扫、清洁、素养、安全)。	若未遵守企业 6S 管理要求,记0分。
	作品 (90分)	信用证 审核 (16分)	2分	(1)买卖双方的名称与地址是否有误;	信用证审核共12个考核点,有8处错误,每处2分,找出错误计1分,修正错误计1分。
			2分	(2)品名、规格、数量、重量、单价是否有误;	
			2分	(3)货物包装、体积是否有误;	
			2分	(4)使用的贸易术语是否有误;	
			2分	(5)合同金额和币种是否有误;	
			2分	(6)合同中溢短装条款是否有误;	
			2分	(7)唛头是否有误;	
			2分	(8)起运港和目的港是否有误;	
			2分	(9)分批装运和转运是否有误;	
			2分	(10)保险险别、保险金额是否有误;	
2分	(11)最迟装运期是否有误;				
2分	(12)汇票的付款期限是否有误;单据条款是否有误。				
商业发票 缮制 (34分)	2分	(1)进口商名称和地址:拼写准确无误;	商业发票缮制部分共17个考核点,每处计2分,未填、错填每处扣2		
	2分	(2)商业发票号码:填写准确无误;			
	2分	(3)商业发票开立日期:填写准确无误;			
	2分	(4)合同号码:填写准确无误;			

			2分	(5) 信用证号码: 填写准确无误;	分。拼写错误每3处扣1分。
			2分	(6) 信用证日期: 填写准确无误;	
			2分	(7) 运输路线装运地: 填写准确无误;	
			2分	(8) 运输路线目的地: 填写准确无误;	
			2分	(9) 价格术语: 填写准确无误;	
			2分	(10) 货物唛头: 填写准确无误;	
			2分	(11) 货物描述: 品名拼写正确, 规格信息填写准确无误;	
			2分	(12) 货物数量: 填写准确无误;	
			2分	(13) 货物单价及单位: 填写准确无误;	
			2分	(14) 货物金额: 填写准确无误;	
			2分	(15) 货物数量总计: 计算准确无误;	
			2分	(16) 货物金额总计: 计算准确无误, 货币名称正确;	
			2分	(17) 总金额大写: 英文拼写正确。	
		提单缮制 (30分)	2分	(1) 发货人条款: 根据信用证中有关提单条款的规定进行正确的填写;	提单缮制部分共15个考核点, 每处计2分, 未填、错填每处扣2分。拼写错误每3处扣1分。
			2分	(2) 收货人条款: 根据信用证中有关提单条款的规定进行正确的填写;	
			2分	(3) 通知人条款: 根据信用证中有关提单条款的规定进行正确的填写;	
			2分	(4) 提单号码: 填写准确无误;	
			2分	(5) 船名及船次: 填写准确无误;	
			2分	(6) 装货港: 填写准确无误;	
			2分	(7) 卸货港: 填写准确无误;	
			2分	(8) 运费支付地点: 填写准确无误;	

			2分	(9) 提单份数: 填写准确无误;	
			2分	(10) 唛头: 填写准确无误;	
			2分	(11) 货物描述条款: 包括货物的总称、包装的总数量等, 填写准确无误;	
			2分	(12) 毛重条款: 计算准确无误, 单位描述正确;	
			2分	(13) 体积条款: 计算准确无误, 单位描述正确;	
			2分	(14) 包装总数量: 填写准确无误;	
			2分	(15) 提单签发地点及日期: 填写准确无误。	
		汇票缮制 (10分)	1分	(1) 出票条款: 开证行完整名称, 拼写准确无误;	汇票缮制部分共10个考核点, 每处计1分, 未填、错填每处扣1分。拼写错误每3处扣1分。
			1分	(2) 信用证号码: 填写准确无误;	
			1分	(3) 信用证开证日期: 填写准确无误;	
			1分	(4) 汇票号码: 填写准确无误;	
			1分	(5) 汇票日期: 填写准确无误;	
			1分	(6) 汇票金额小写: 填写准确无误;	
			1分	(7) 汇款期限: 填写准确无误;	
			1分	(8) 受款人: 信用证下以议付行为受款人, 托收汇票下以托收行(出口地银行)为受款人: 信息完整无误, 拼写正确;	
			1分	(9) 金额及币种大写: 币种与金额必须与信用证保持一致, 拼写准确无误;	
			1分	(10) 付款人: 信用证项下付款人为开证行或指定银行: 信息完整无误, 拼写正确。	

6. 试题编号：2-2-6 信用证审核、单证缮制

(1) 任务描述

任务 1：信用证审核

熟悉 UCP600 相关条款；读懂外贸合同条款；读懂并审核 L/C 各条款；修改 L/C 中的问题条款。

注意：考试资料中的信用证为错误的信用证，考试中涉及到信用证的信息必须参考修改正确的信用证的信息，否则造成的制单错误将不计分。

任务 2：商业发票缮制

分析信用证中涉及商业发票缮制的相关条款；准确缮制商业发票；确保缮制的商业发票与信用证的条款一致。

任务 3：提单缮制

分析信用证的装运条款；准确缮制提单；确保缮制的提单与信用证的条款一致。

任务 4：汇票缮制

分析信用证中涉及汇票缮制的相关条款；准确缮制汇票；确保缮制的汇票与信用证的条款一致。

背景资料

1、出口方基本情况

Company	BROAD AIR QUALITY TECHNOLOGY GROUP
Url	http://www.broad.com:8089/english/
Office Address	YUANDA TOWN, YUANDA 3RD ROAD, CHANGSHA, HUNAN, CHINA
Zip code	410138
Phone	86-731-84086688

Fax	86-731-84610087
E-mail	international@broad.net

2、进口方基本情况

Company	INNOVAIR CORPORATION
Url	http://www.innovair.com/
Office Address	AV. PAEO DE LA REFORMA NO. 350, PISO 11 MEXICO CITY, MEXICO
Tollfree	无
Phone	(55) 9171-8465
Fax	无

3、合同

销售合同

SALES CONTRACT

SELLER: BROAD AIR QUALITY TECHNOLOGY GROUP **NO.:** BRA10145-654
YUANDA TOWN, YUANDA 3RD ROAD, CHANGSHA, **DATE:** MAY 15, 2022
HUNAN, CHINA **SIGNED IN:** CHANGSHA

BUYER: INNOVAIR CORPORATION
AV. PAEO DE LA REFORMA NO. 350, PISO 11 MEXICO CITY, MEXICO

This contract is made by and agreed between the BUYER and SELLER, in accordance with the terms and conditions stipulated below.

1. Commodity & Specification	2. Quantity	3. Unit Price & Trade Terms	4. Amount
CFR MEXICO CITY			
BROAD PUMPSET BY50 TYPE (PUMPSET FOR 582KW/165RT CHILLERS)	3 SETS	USD 4,200/SET	USD 12,600.00
BY300 TYPE (PUMPSET FOR 3489KW/992RT CHILLERS)	5 SETS	USD 4,700/SET	USD 23,500.00
BY1000 TYPE (PUMPSET FOR 11630KW/3307RT CHILLERS)	5 SETS	USD 5,200/SET	USD 26,000.00

Total:	13 SETS		USD 62,100.00
---------------	---------	--	---------------

- 5. Total Value** SAY U.S. DOLLARS SIXTY TWO THOUSAND ONE HUNDRED ONLY.
- 6. Packing** 1SET PER CASE
PACKED IN 13 CASES
- 7. Shipping Marks** MEXICO
BRA10145-654
NO. 1-13
- 8. Time of Shipment & means of Transportation** TO BE EFFECTED BEFORE THE END OF JUNE 2022 FROM SHANGHAI TO MEXICO CITY WITH PARTIAL SHIPMENT AND TRANSSHIPMENT NOT ALLOWED.
- 9. Port of Loading & Destination** FROM: SHANGHAI
TO: MEXICO CITY
- 10. Insurance** THE BUYER SHALL COVER INSURANCE AGAINST ALL RISKS AND WAR RISK FOR 120% OF THE TOTAL INVOICE VALUE AS PER THE RELEVANT OCEAN MARINE CARGO OF P.I.C.C. DATED 1/1/1981
- 11. Terms of Payment** TO BE MADE BY SIGHT L/C
- 12. Remarks**

The Buyer
INNOVAIR CORPORATION

(signature)

The Seller
BROAD AIR QUALITY
TECHNOLOGY GROUP

(signature)

4、信用证

- 27: SEQUENCE OF TOTAL 1/1
- 40A: FORM OF DOCUMENTARY CREDIT REVOCABLE
CREDIT
- 20: DOCUMENTARY CREDIT CITYMB1023/2345
NUMBER
- 31C: DATE OF ISSUE 220520
- 31D: DATE AND PLACE OF EXPIRY 220421 CHINA
- 50: APPLICANT
INNOVAIR CORPORATION
AV. PAEO DE LA REFORMA NO. 350, PISO 11 COLONIA
JUAREZ, MEXICO
- 59: BENEFICIARY
BROAD AIR QUALITY TECHNOLOGY GROUP
YUANDA TOWN, YUANDA 3RD ROAD, CHANGSHA
HUNAN, CHINA

32B:	AMOUNT	USD 26,100.00
39B:	CREDIT AMT	NOT EXCEEDING
41D:	AVAILABLE WITH BY	ANY BANK IN CHINA
42C:	DRAFTS AT	30 DAYS AFTER SIGHT
42D:	DRAWEE	CITY BANK, MEXICO BRANCH
43P:	PARTIAL SHIPMENTS	ALLOWED
43T:	TRANSSHIPMENT	NOT ALLOWED
44A:	LOADING ON BOARD	SHENZHEN, CHINA
44B:	FOR TRANSPORTATION TO	MEXICO CITY, MEXICO
44C:	LATEST DATE OF SHIPMENT	220630
45A:	DESCRIPTION OF GOODS	
	BROAD PUMPSET	
	3 SETS BY50 TYPE (PUMPSET FOR 582KW/165RT CHILLERS)	USD 4,200/SET
	5 SETS BY300 TYPE (PUMPSET FOR 3489KW/992RT CHILLERS)	USD 4,700/SET
	5 SETS BY1000 TYPE (PUMPSET FOR 11630KW/3307RT CHILLERS)	USD 5,200/SET
	CIF MEXICO CITY	
46A:	DOCUMENTS REQUIRED	
	+SIGNED COMMERCIAL INVOICE IN TRIPLICATE.	
	+PACKING LIST IN TRIPLICATE.	
	+CERTIFICATE OF ORIGIN GSP CHINA FORM A, ISSUED BY THE CHAMBER OF COMMERCE OR OTHER AUTHORITY DULY ENTITLED FOR THIS PURPOSE.	
	+FULL SET OF CLEAN ON BOARD OCEAN BILLS OF LADING, MADE OUT TO ORDER OF SHIPPER AND BLANK ENDORSED AND MARKED "FREIGHT PREPAID" AND NOTIFY APPLICANT.	
	+FULL SET OF NEGOTIABLE INSURANCE POLICY OR CERTIFICATE BLANK ENDORSED FOR 120 PCT OF INVOICE VALUE COVERING ALL RISKS AND WAR RISK.	
	+SHIPPING ADVICES MUST BE SENT TO APPLICANT ON THE DATE OF SHIPMENT ADVISING SHIPPING MARKS, COMMODITY NAME, CARTON NUMBERS, TOTAL GROSS WEIGHT, VESSEL NAME, BILL OF LADING NO., PORT OF LOADING, DESTINATION, CONTRACT NO., INVOICE NO., LETTER OF CREDIT NO.	

+COPY OF LETTER FROM BENEFICIARY TO OUR APPLICANT EVIDENCING A NON NEGOTIABLE BILL OF LADING TOGETHER WITH COPY OF OTHER DOCUMENTS WAS SENT DIRECTLY TO THEM AFTER ONE DAY FROM SHIPMENT DATE.

71B: CHARGES

ALLBANKING CHARGES OUTSIDE MEXICO ARE FOR ACCOUNT OF APPLICANT.

48: PERIOD FOR PRESENTATION

DOCUMENTS MUST BE PRESENTED WITHIN 15 DAYS AFTER THE DATE OF SHIPMENT BUT WITHIN THE VALIDITY OF THE CREDIT.

5、相关资料

(1) INVOICE NO.: BR1003778

(2) INVOICE DATE: MAY 25, 2022

(3) PACKING G. W.: 57 KGS/CASE

N. W.: 52 KGS/CASE

MEAS: 0.4×0.8×0.5 CBM

PACKED IN 13 CASES

TOTAL ONE 20' CONTAINER

(4) VESSEL: HONGHE 0912

(5) B/L NO.: COSE3322012

(6) B/L DATE: JUNE 20, 2022

(7) POLICY NO.: PIC9977

(8) REFERENCE NO.: 20220617

抽考试题

1、请根据考试资料中的合同 3 审核错误的信用证 4，指出不符之处并修正。

(本题共 16 分)

1. _____
2. _____
3. _____
4. _____
5. _____
6. _____
7. _____
8. _____

2、请根据以上资料缮制商业发票。(本题共 34 分)

(注：信用证的信息必须是修正后的正确信息)

远大集团

Broad Air Quality Technology Group

Yunda Town, Yuanda 3rd Road, Changsha, Hunan, China

TEL: 86-731-84086688 FAX: 86-731-84610087

商业发票

COMMERCIAL INVOICE

TO:	INVOICE NO.:			
	INVOICE DATE:			
	S/C NO.:			
FROM:	L/C NO.:			
TO:	L/C DATE:			
Marks and Numbers	Description of Goods	Quantity	Unit Price	Amount

TOTAL PACKAGES(IN WORDS)		
Freight and charges		
		Place and date of issue
		Signed for the Carrier SHANGHAI OCEAN SHIPPING CO., LTD. 丁浩

*Applicable only when document used as a Through Bill of Lading

4、请根据以上资料缮制汇票。（本题共 10 分）

（注：信用证的信息必须是修正后的正确信息）

BILL OF EXCHANGE

Drawn under _____

L/C No. _____

Dated _____

No. _____ **Exchange for** _____ **Changsha, China.**

_____ **At** _____ **sight of this FIRST of Exchange**

(Second of exchange being unpaid)

Pay to the order of _____

The sum of _____

To _____

(2) 实施条件

项目	基本实施条件	备注
场地	每个商务英语实训室配置 40 个操作台面和座位，每个实训室照明通风良好。	必备
设备	每个商务英语实训室配有 1 台服务器、40—50 台计算机，并安装 Office 办公软件，配置局域网。	必备
测评专家	每 40 名考生配备 1 名考评员。考评员要求具备至少二年以上从事国际贸易工作经验或二年以上外贸单证缮制实践教学指导经历。	必备

(3) 考核时量

考核时间：90 分钟

(4) 评分标准

模块总分	评价内容	配分		考核点	备注
岗位核心技能模块项目二：外贸单证缮制（总分 100 分，占总评	职业素养与操作规范（10 分）	职业素养（6 分）	2 分	（1）具备外贸从业人员基本素质，认真严谨、耐心细致、恪守信誉、实事求是、服从安排，听从指挥、举止文明；	在考试过程中不服从安排、举止不得当者，记 0 分。
			2 分	具备对外贸合同及信用证信息甄别正误及修正能力、正确缮制单证能力，做到数据计算准确、信息填写正确、单据填写完整；	

分的 50%)			2分	(3)具备正确规范操作外贸电商平台能力,具有对外贸产品筛选关键信息的能力,符合外贸行业对外贸电商运营等相关岗位需求。	与所述能力及素养不符,扣1-2分。
		操作规范 (4分)	2分	(1)具备使用办公设备和 Office 办公软件的能力,在考核过程中以及考核结束后,不私自更换电脑、不随意关闭或重启电脑,没征求监考老师同意不随意提前或推迟交卷;	若私自更换电脑、随意关闭或重启电脑,记0分。
			2分	(2)能严格遵守企业 6S 管理要求(整理、整顿、清扫、清洁、素养、安全)。	若未遵守企业 6S 管理要求,记0分。
	作品 (90分)	信用证 审核 (16分)	2分	(1)买卖双方的名称与地址是否有误;	信用证审核共12个考核点,有8处错误,每处2分,找出错误计1分,修正错误计1分。
			2分	(2)品名、规格、数量、重量、单价是否有误;	
			2分	(3)货物包装、体积是否有误;	
			2分	(4)使用的贸易术语是否有误;	
			2分	(5)合同金额和币种是否有误;	
			2分	(6)合同中溢短装条款是否有误;	
			2分	(7)唛头是否有误;	
			2分	(8)起运港和目的港是否有误;	
			2分	(9)分批装运和转运是否有误;	
			2分	(10)保险险别、保险金额是否有误;	
			2分	(11)最迟装运期是否有误;	
2分	(12)汇票的付款期限是否有误;单据条款是否有误。				
商业发票 缮制 (34分)	2分	(1)进口商名称和地址:拼写准确无误;	商业发票缮制部分共17个考核点,每处计2分,未填、错填每处扣2		
	2分	(2)商业发票号码:填写准确无误;			
	2分	(3)商业发票开立日期:填写准确无误;			
	2分	(4)合同号码:填写准确无误;			

			2分	(5) 信用证号码: 填写准确无误;	分。拼写错误每3处扣1分。
			2分	(6) 信用证日期: 填写准确无误;	
			2分	(7) 运输路线装运地: 填写准确无误;	
			2分	(8) 运输路线目的地: 填写准确无误;	
			2分	(9) 价格术语: 填写准确无误;	
			2分	(10) 货物唛头: 填写准确无误;	
			2分	(11) 货物描述: 品名拼写正确, 规格信息填写准确无误;	
			2分	(12) 货物数量: 填写准确无误;	
			2分	(13) 货物单价及单位: 填写准确无误;	
			2分	(14) 货物金额: 填写准确无误;	
			2分	(15) 货物数量总计: 计算准确无误;	
			2分	(16) 货物金额总计: 计算准确无误, 货币名称正确;	
			2分	(17) 总金额大写: 英文拼写正确。	
		提单缮制 (30分)	2分	(1) 发货人条款: 根据信用证中有关提单条款的规定进行正确的填写;	提单缮制部分共15个考核点, 每处计2分, 未填、错填每处扣2分。拼写错误每3处扣1分。
			2分	(2) 收货人条款: 根据信用证中有关提单条款的规定进行正确的填写;	
			2分	(3) 通知人条款: 根据信用证中有关提单条款的规定进行正确的填写;	
			2分	(4) 提单号码: 填写准确无误;	
			2分	(5) 船名及船次: 填写准确无误;	
			2分	(6) 装货港: 填写准确无误;	
			2分	(7) 卸货港: 填写准确无误;	
			2分	(8) 运费支付地点: 填写准确无误;	

			2分	(9) 提单份数: 填写准确无误;	
			2分	(10) 唛头: 填写准确无误;	
			2分	(11) 货物描述条款: 包括货物的总称、包装的总数量等, 填写准确无误;	
			2分	(12) 毛重条款: 计算准确无误, 单位描述正确;	
			2分	(13) 体积条款: 计算准确无误, 单位描述正确;	
			2分	(14) 包装总数量: 填写准确无误;	
			2分	(15) 提单签发地点及日期: 填写准确无误。	
		汇票缮制 (10分)	1分	(1) 出票条款: 开证行完整名称, 拼写准确无误;	汇票缮制部分共10个考核点, 每处计1分, 未填、错填每处扣1分。拼写错误每3处扣1分。
			1分	(2) 信用证号码: 填写准确无误;	
			1分	(3) 信用证开证日期: 填写准确无误;	
			1分	(4) 汇票号码: 填写准确无误;	
			1分	(5) 汇票日期: 填写准确无误;	
			1分	(6) 汇票金额小写: 填写准确无误;	
			1分	(7) 汇款期限: 填写准确无误;	
			1分	(8) 受款人: 信用证下以议付行为受款人, 托收汇票下以托收行(出口地银行)为受款人: 信息完整无误, 拼写正确;	
1分	(9) 金额及币种大写: 币种与金额必须与信用证保持一致, 拼写准确无误;				
1分	(10) 付款人: 信用证项下付款人为开证行或指定银行: 信息完整无误, 拼写正确。				

7. 试题编号：2-2-7 合同审核、单证缮制

(1) 任务描述

任务 1：合同审核

读懂谈判备忘录的内容；读懂并审核合同各条款；修改合同中的问题条款。

注意：考试资料中的合同为错误的合同，考试中涉及到合同的信息必须参考修改正确后的合同信息，否则造成的制单错误将不计分。

任务 2：装箱单缮制

分析合同中涉及装箱单缮制的相关条款；准确缮制装箱单；确保缮制的装箱单与合同的条款一致。

任务 3：提单缮制

分析合同的装运条款；准确缮制提单；确保缮制的提单与合同的条款一致。

任务 4：产地证缮制

分析合同中涉及产地证缮制的相关条款；准确缮制产地证；确保缮制的产地证与合同的条款一致。

背景资料

1、出口方基本情况

Company	HUNAN PROVINCIAL LIGHT INDUSTRIAL PRODUCTS I/E CORP.
Url	http://ccn.mofcom.gov.cn/923748
Office Address	NO. 4 EAST WUYI ROAD, CHANGSHA, HUNAN, CHINA
Zip code	410001
Phone	86-731-82287135
Fax	86-731-82287136
E-mail	hnqgyp_123@163.com

2、进口方基本情况

Company	SEOW KHIM POLYTHELENE CO PTE LTD
Url	http://www.partyware.com.sg/index.htm
Office Address	28 LOYANG DRIVE SKP INDUSTRIAL BUILDING, SINGAPORE
Tollfree	无
Phone	(+65) 6545 2828
Fax	(+65) 6542 1200

3、谈判备忘录

Minutes of a Meeting	
TIME:	Mar. 1-3, 2022
PLACE:	Conference Room of DOLTON Hotel, Changsha, Hunan, China
PURPOSE:	To come to an agreement over the transaction of the interested products.
PRESIDING:	Mr. Liuzhong (Party A: Sales Manager of Hunan Provincial Light Industrial Products I/E Corp.)
PRESENT:	Mr. John Smith (Party B: Purchasing Manager of Seow Khim Polythelene Co Pte Ltd)
SUMMARY OF THE MEETING	
<p>After several rounds of negotiation, Party A and Party B come to terms on March 3 over the transaction of 6000 sets of Ceramic Dinner Set. A brief summary of the meeting is as follows:</p> <ol style="list-style-type: none"> 1. Name of commodity and specifications: JHT-229 12-Piece Ceramic Dinner Set 2. Packing: To be packed in 2SETS/CARTON 3. Weight and measurement: G. W.: 6.5 KGS/ CARTON N. W.: 5.5 KGS/ CARTON 	

MEAS.: 0.044 CBM/ CARTON

4. Shipping marks: SINGAPORE

HLIP-45152

NO. 1-3000

5. Unit price and quantity: USD 6.50/set CIF Singapore, 6,000 sets

6. Time and terms of shipment:

To be shipped within 45 days after the contract is signed.

Transshipment and partial shipment is not allowed.

7. Ports of loading and destination: From Shanghai to Singapore

8. Insurance: To be covered against W.P.A. and Clash & Breakage & War Risk

9. Terms of payment: BY D/P AT SIGHT

10. Documents:

- Commercial Invoice in triplicate.
- Packing List in triplicate.
- Full set of clean on board ocean bills of lading, made out to order of shipper and blank endorsed and marked "freight prepaid" and notify the buyer.
- Shipping advices must be sent to buyer on the date of shipment advising shipping marks, commodity name, carton numbers, total gross weight, vessel name, bill of lading No., port of loading, destination, contract No. and invoice No..
- Certificate of Origin in duplicate.
- Insurance policy/certificate blank endorsed covering W.P.A. and Clash & Breakage & War Risk for 110% of the total invoice value.

4、合同

销售合同

SALES CONTRACT

SELLER: HUNAN PROVINCIAL LIGHT INDUSTRIAL PRODUCTS I/E CORP.
NO. 4 EAST WUYI ROAD, CHANGSHA, HUNAN CHINA

NO.: HLIP-45152
DATE: MAR. 3, 2022
SIGNED IN: CHANGSHA

BUYER: SEOW KHIM POLYTHELENE CO LTD
28, LOYANG DRIVE SKP INDUSTRIAL BUILDING, SINGAPORE

This contract is made by and agreed between the BUYER and SELLER, in accordance with the terms and conditions stipulated below.

1. Commodity & Specification	2. Quantity	3. Unit Price &	4. Amount
------------------------------	-------------	-----------------	-----------

		Trade Terms	
CIF SINGAPORE			
JHT-228 12-PIECE DINNER SET	6,000 SETS	USD 6.50/SET	USD 39,000.00
Total:	6,000 SETS		USD 39,000.00

- 5. Total Value** SAY U.S. DOLLARS THIRTEEN NINE THOUSAND ONLY.
- 6. Packing** JHT-229 12-PIECE: 2 SETS IN ONE BAG
TOTAL: 3,000 CARTONS.
- 7. Shipping Marks** SINGAPORE
CS450532
NO.1-3000
- 8. Time of Shipment & means of Transportation** TO BE EFFECTED BEFORE MARCH 18, 2022 FROM SHANGHAI TO SINGAPORE WITH PARTIAL SHIPMENT NOT ALLOWED AND TRANSHIPMENT ALLOWED.
- 9. Port of Loading & Destination** FROM: CHANGSHA
TO: SINGAPORE
- 10. Insurance** THE SELLER SHALL COVER THE GOODS AGAINST W.P.A. AND CLASH & BREAKAGE & WAR RISK FOR 120% OF THE TOTAL INVOICE VALUE AS PER THE RELEVANT OCEAN MARINE CARGO OF P.I.C.C. DATED 1/1/1981
- 11. Terms of Payment** TO BE MADE BY D/P AT SIGHT
- 12. Remarks**

The Buyer	The Seller
SEOW KHIM POLYTHELENE CO PTE LTD.	HUNAN PROVINCIAL LIGHT INDUSTRIAL PRODUCTS I/E CORP.
(signature)	(signature)

5、相关资料

- (1) INVOICE NO.: JCS10752
- (2) INVOICE DATE: MARCH 23, 2022
- (3) PACKING

G.W.(KGS/CTN)	N. W. (KGS/ CTN)	MEAS (CBM/ CTN)
---------------	------------------	-----------------

6.5

5.5

0.044

PACKED IN 3,000 CARTONS

PACKED IN FOUR 20' CONTAINERS

- (4) VESSEL: DONGFENG V. 216
- (5) B/L NO.: COSU76042051
- (6) B/L DATE: APRIL 18, 2022
- (7) POLICY NO.: AP160419
- (8) CERTIFICATE NO.: 20220420
- (9) H.S. CODE: 6911101000
- (10) COLLECTING BANK: BANK OF CHINA, HUNAN BRANCH

抽考试题

1、请根据考试资料中的谈判备忘录 3 审核错误的合同 4，指出不符之处并修正。

(本题共 16 分)

- 1. _____
- 2. _____
- 3. _____
- 4. _____
- 5. _____
- 6. _____
- 7. _____
- 8. _____

2、请根据以上资料缮制装箱单。(本题共 34 分)

(注：合同的信息必须是修正后的正确信息)

湖南轻工产品进出口公司

Hunan Provincial Light Industrial Products I/E Corp.

No. 4 East Wuyi Road, Changsha, Hunan, China

TEL: 86-731-82287135 FAX: 86-731-82287136

装箱单

PACKING LIST

TO:

INVOICE NO.:

DATE:

S/C NO.:

FROM:

TO:

MARKS & NO.	DESCRIPTION S & PACKING	QTY	MEAS (M ³)	N.W. (KGS)	G.W. (KGS)
Total:					

SAY TOTAL :

HUNAN PROVINCIAL LIGHT INDUSTRIAL PRODUCTS I/E CORP.

湖南轻工产品进出口公司

李明远

(Authorized Signature)

3、请根据以上资料缮制提单。（本题共 30 分）

（注：合同的信息必须是修正后的正确信息）

Shipper		<p>BILL OF LADING</p> <p>B/L NO.:</p> <p>中国远洋运输公司</p> <p>CHINA OCEAN SHIPPING</p> <p>ORIGINAL</p>
Consignee or order		
Notify Party		
*Pre carriage by	*Place of Receipt	
Ocean Vessel Voy. No.	Port of Loading	

Port of discharge	*Final destination	Freight payable at	Number original Bs/L
Marks and Numbers	Number and kind of packages; Description	Gross weight	Measurement m³
TOTAL PACKAGES(IN WORDS)			
Freight and charges			
			Place and date of issue
			Signed for the Carrier SHANGHAI OCEAN SHIPPING CO., LTD. 丁浩

*Applicable only when document used as a Through Bill of Lading

4、请根据以上资料缮制一般原产地证。（本题共 10 分）
（注：合同的信息必须是修正后的正确信息）

ORIGINAL

1.Exporter: (Exporter's business name, address, country)	Certificate No.
	CERTIFICATE OF ORIGIN

2. Consignee: (Consignee's name, address, country)		OF THE PEOPLE'S REPUBLIC OF CHINA		
3. Means of transport and route:		5. For certifying authority use only		
4. Country/ region of destination				
6. Marks and numbers of Packages:	7. Number and kind of packages; description of goods:	8. H.S.Code	9. Gross weight or other quantity:	10. Number and date of invoices:
11. Declaration by the exporter :		12. <u>Certificate</u>		

<p>The undersigned hereby declares that the above details and statements are correct, that all the goods were produced in China and that they comply with the Rules of Origin of the People's Republic of China.</p> <p>HUNAN PROVINCIAL LIGHT INDUSTRIAL PRODUCTS I/E CORP</p> <p>湖南轻工产品进出口公司 李明远 (Authorized Signature)</p> <p>-----</p> <p>Place and date, signature of authorized Signatory</p>	<p>It is hereby certified on the basis of control carried out, that the declaration by the exporter is correct.</p>  <p>-----</p> <p>Place and date, signature and stamp of Certifying Authority</p>
---	--

(2) 实施条件

项目	基本实施条件	备注
场地	每个商务英语实训室配置 40 个操作台面和座位，每个实训室照明通风良好。	必备
设备	每个商务英语实训室配有 1 台服务器、40—50 台计算机，并安装 Office 办公软件，配置局域网。	必备
测评专家	每 40 名考生配备 1 名考评员。考评员要求具备至少二年以上从事国际贸易工作经验或二年以上外贸单证缮制实践教学指导经历。	必备

(3) 考核时量

考核时间：90 分钟

(4) 评分标准

模块总分	评价内容	配分	考核点	备注		
岗位核心 技能模块项 目二： 外贸单证 缮制 (总分 100 分，占总评 分的 50%)	职业素养 与 操作规范 (10分)	职业素养 (6分)	2分	(1) 具备外贸从业人员基本素质，认真严谨、耐心细致、恪守信誉、实事求是、服从安排，听从指挥、举止文明；	在考试过程中不服从安排、举止不得当者，记 0 分。	
			2分	具备对外贸合同及信用证信息甄别正误及修正能力、正确缮制单证能力，做到数据计算准确、信息填写正确、单据填写完整；	与上述能力及素养不符，扣 1-2 分。	
			2分	(3) 具备正确规范操作外贸电商平台能力，具有对外贸产品筛选关键信息的能力，符合外贸行业对外贸电商运营等相关岗位需求。	与上述能力及素养不符，扣 1-2 分。	
		操作规范 (4分)	2分	(1) 具备使用办公设备和 Office 办公软件的能力，在考核过程中以及考核结束后，不私自更换电脑、不随意关闭或重启电脑，没征求监考老师同意不随意提前或推迟交卷；	若私自更换电脑、随意关闭或重启电脑，记 0 分。	
			2分	(2) 能严格遵守企业 6S 管理要求（整理、整顿、清扫、清洁、素养、安全）。	若未遵守企业 6S 管理要求，记 0 分。	
		作品 (90分)	合同审核 (16分)	2分	(1) 买卖双方的名称与地址是否有误；	合同审核共 12 个考核点，有 8 处错误，每处 2 分，找出错误计 1 分，修正错误计 1 分。
				2分	(2) 品名、规格、数量、重量、单价是否有误；	
	2分			(3) 货物包装、体积是否有误；		
	2分			(4) 使用的贸易术语是否有误；		
	2分			(5) 合同金额和币种是否有误；		
	2分			(6) 合同中溢短装条款是否有误；		
	2分	(7) 唛头是否有误；				
	2分	(8) 起运港和目的港是否有误；				
2分	(9) 分批装运和转运是否有误；					

			2分	(10) 保险险别、保险金额是否有误;	
			2分	(11) 最迟装运期是否有误;	
			2分	(12) 汇票的付款期限是否有误。	
		装箱单缮制 (34分)	2分	(1) 进口商名称和地址: 拼写准确无误;	装箱单缮制部分共17个考核点, 每处计2分, 未填、错填每处扣2分。拼写错误每3处扣1分。
			2分	(2) 商业发票号码: 填写准确无误;	
			2分	(3) 商业发票开立日期: 填写准确无误;	
			2分	(4) 合同号码: 填写准确无误;	
			2分	(5) 装运港: 填写准确无误;	
			2分	(6) 目的港: 填写准确无误;	
			2分	(7) 唛头: 描述准确无误;	
			2分	(8) 货物描述及包装: 品名及规格信息填写准确无误, 计量数与外包装数关系表述准确无误;	
			2分	(9) 货物各自外包装总数量: 计算准确无误;	
			2分	(10) 货物各自总体积: 计算准确无误;	
			2分	(11) 货物各自总净重: 计算准确无误;	
			2分	(12) 货物各自总毛重: 计算准确无误;	
			2分	(13) 货物外包装总数量: 计算准确无误;	
			2分	(14) 货物总体积: 计算准确无误;	
			2分	(15) 货物总净重: 计算准确无误;	
			2分	(16) 货物总毛重: 计算准确无误;	
			2分	(17) 货物外包装总数量大写: 英文拼写正确。	
		提单缮制 (30分)	2分	(1) 发货人条款: 根据信用证中有关提单条款的规定进行正确的填写;	提单缮制部分共15个考核点, 每处计2分, 未填、错
			2分	(2) 收货人条款: 根据信用证中有关提单	

				条款的规定进行正确的填写；	填 每 处 扣 2 分。拼写错误每 3 处扣 1 分。
		2 分	(3) 通知人条款：根据信用证中有关提单条款的规定进行正确的填写；		
		2 分	(4) 提单号码：填写准确无误；		
		2 分	(5) 船名及船次：填写准确无误；		
		2 分	(6) 装货港：填写准确无误；		
		2 分	(7) 卸货港：填写准确无误；		
		2 分	(8) 运费支付地点：填写准确无误；		
		2 分	(9) 提单份数：填写准确无误；		
		2 分	(10) 唛头：填写准确无误；		
		2 分	(11) 货物描述条款：包括货物的总称、包装的总数量等，填写准确无误；		
		2 分	(12) 毛重条款：计算准确无误，单位描述正确；		
		2 分	(13) 体积条款：计算准确无误，单位描述正确；		
		2 分	(14) 包装总数量：填写准确无误；		
		2 分	(15) 提单签发地点及日期：填写准确无误。		
		产地证缮制 (10 分)	1 分	(1) 原产地证书编号：填写准确无误；	
			1 分	(2) 发货方：名称、详细地址及国家（地区），拼写准确无误；	
			1 分	(3) 收货方：最终收货方的名称、详细地址及国家（地区），拼写准确无误；	
			1 分	(4) 运输方式及路线：起运港、目的港及运输方式，填写准确无误；	
			1 分	(5) 目的地国家（地区）：货物抵达的最	

				终进口国（地区），填写准确无误；	
			1分	（6）唛头：填写准确无误；	
			1分	（7）包装数量及种类、货物描述：拼写正确，并在末行加上截止线；	
			1分	（8）海关代码（一般原产地证）、原产地标准（普惠制产地证 Form A）：填写准确无误；	
			1分	（9）所有商品总毛重或者其他数量：数量计算准确。	
			1分	（10）发票的号码和开立日期：填写准确无误。	

8. 试题编号：2-2-8 合同审核、单证缮制

（1）任务描述

任务 1：合同审核

读懂谈判备忘录的内容；读懂并审核合同各条款；修改合同中的问题条款。

注意：考试资料中的合同为错误的合同，考试中涉及到合同的信息必须参考修改正确后的合同信息，否则造成的制单错误将不计分。

任务 2：装箱单缮制

分析合同中涉及装箱单缮制的相关条款；准确缮制装箱单；确保缮制的装箱单与合同的条款一致。

任务 3：提单缮制

分析合同的装运条款；准确缮制提单；确保缮制的提单与合同的条款一致。

任务 4：产地证缮制

分析合同中涉及产地证缮制的相关条款；准确缮制产地证；确保缮制的产地证与合同的条款一致。

背景资料

1、出口方基本情况

Company	HUNAN PROVINCIAL LIGHT INDUSTRIAL PRODUCTS I/E CORP.
Url	http://ccn.mofcom.gov.cn/923748
Office Address	NO. 4 EAST WUYI ROAD, CHANGSHA, HUNAN, CHINA
Zip code	410001
Phone	86-731-82287135
Fax	86-731-82287136
E-mail	hnqgyp_123@163.com

2、进口方基本情况

Company	NASEEB INTERNATIONAL CORP.
Url	http://www.naseebintl.com/
Office Address	1600 BRIMLEY ROAD, SCARBOROUGH, ONTARIO, CANADA
Tollfree	无
Phone	416-917-7344
Fax	416-292-9943

3、谈判备忘录

Minutes of a Meeting	
TIME:	Oct. 1-3, 2022
PLACE:	Conference Room of Royal Holiday Hotel, Changsha, Hunan, China
PURPOSE:	To come to an agreement over the transaction of the interested products.
PRESIDING:	Mr. Liuzhong (Party A: Sales Manager of Hunan Provincial Light Industrial Products Import & Export Corp.)

PRESENT:	Mr. Hugh Steward (Party B: Purchasing Manager of Naseeb International Corp.)
-----------------	---

SUMMARY OF THE MEETING

After several rounds of negotiation, Party A and Party B come to terms on October 3 over the transaction of 2,000 pairs of Fuxia Leather Floral Sandals. A brief summary of the meeting is as follows:

1. Name of commodity and specifications:
FUXIA LEATHER FLORAL SANDALS
BIAN-2012
2. Packing: To be packed in cartons of 10 pairs each
3. Weight and measurement:
G.W.: 15 KGS/ CARTON
N.W.: 14 KGS/ CARTON
MEAS.: 0.8 CBM/ CARTON
4. Shipping marks: N/M
5. Unit price and quantity: USD 46.20/pair CIF Vancouver, 2,000 pairs
6. Time and terms of shipment:
To be shipped within 60 days after the contract is signed.
Transshipment is not allowed and partial shipment is allowed.
7. Ports of loading and destination: From Shanghai to Vancouver
8. Insurance: To be covered against All Risks & War Risk
9. Terms of payment: BY D/P AT SIGHT
10. Documents:
 - Commercial Invoice in triplicate.
 - Packing List in triplicate.
 - Full set of clean on board ocean bills of lading, made out to order of shipper and blank endorsed and marked "freight prepaid" and notify the buyer.
 - Shipping advices must be sent to buyer on the date of shipment advising shipping marks, commodity name, carton numbers, total gross weight, vessel name, bill of lading No., port of

loading, destination, contract No. and invoice No.

- Certificate of Origin in duplicate.
- Insurance policy/certificate blank endorsed covering all risks and war risk for 120% of the total invoice value.

4、合同

销售合同

SALES CONTRACT

SELLER: HUNAN PROVINCIAL LIGHT INDUSTRIAL PRODUCTS CORP.
NO. 4 EAST WUYI ROAD, CHANGSHA, HUNAN, CHINA

NO.: HLIP-05762
DATE: OCT. 3, 2022
SIGNED IN: CHANGSHA

BUYER: NASB INTERNATIONAL CORP.
1600 BRIMLEY ROAD, SCARBOROUGH, ONTARIO, CANADA

This contract is made by and agreed between the BUYER and SELLER, in accordance with the terms and conditions stipulated below.

1. Commodity & Specification	2. Quantity	3. Unit Price & Trade Terms	4. Amount
CIF VANCOUVER			
FUXIA LEATHER FLORAL SANDALS BIAN-2021	2,000 PAIRS	USD 46.00/PAIR	USD 92,400.00
Total:	2,000 PAIRS		USD 92,400.00

5. Total Value SAY U.S. DOLLARS NINETY TWO THOUSAND FOUR HUNDRED ONLY.

6. Packing ONE PAIR IN ONE BOX AND 10 BOXES IN ONE CARTON
TOTAL: 2,000 CARTONS

7. Shipping Marks N/M

8. Time of Shipment & means of Transportation TO BE EFFECTED NO LATER THAN DEC. 3, 2022 FROM SHANGHAI TO VANCOUVER WITH PARTIAL SHIPMENT AND TRANSSHIPMENT ALLOWED.

9. Port of Loading & Destination FROM: SHANGHAI
TO: MONTREAL

10. Insurance THE SELLER SHALL COVER THE GOODS AGAINST ALL RISKS FOR 120% OF THE TOTAL INVOICE VALUE AS PER THE RELEVANT OCEAN MARINE CARGO OF P.I.C.C. DATED 1/1/1981

11. Terms of Payment TO BE MADE BY D/P AT SIGHT

12. Remarks

The Buyer

NASEEB INTERNATIONAL
CORP.
(signature)

The Seller

HUNAN PROVINCIAL LIGHT
INDUSTRIAL PRODUCTS I/E CORP.
(signature)

5、相关资料

- (1) INVOICE NO.: YST10253
- (2) INVOICE DATE: OCT. 23, 2022
- (3) PACKING

G. W.(KGS/CARTON)	N. W.(KGS/CARTON)	MEAS (CBM/CARTON)
15	14	0.8

PACKED IN 200 CARTONS
TOTAL THREE 40' CONTAINERS

- (4) VESSEL: HONGHE V. 188
- (5) B/L NO.: JUC213608
- (6) B/L DATE: DEC. 01, 2022
- (7) POLICY NO.: FW161129
- (8) CERTIFICATE NO.: 20221127
- (9) H.S.CODE: 6403990090
- (10) COLLECTING BANK: BANK OF CHINA, HUNAN BRANCH

抽考试题

1、请根据考试资料中的谈判备忘录 3 审核错误的合同 4，指出不符之处并修正。
(本题共 16 分)

- 1. _____
- 2. _____
- 3. _____
- 4. _____
- 5. _____
- 6. _____

Shipper		BILL OF LADING B/L NO.: 中国远洋运输公司 CHINA OCEAN SHIPPING ORIGINAL	
Consignee or order			
Notify Party			
*Pre carriage by	*Place of Receipt		
Ocean Vessel Voy. No.	Port of Loading		
Port of discharge	*Final destination	Freight payable at	Number original Bs/L
Marks and Numbers	Number and kind of packages; Description	Gross weight	Measurement m ³
<hr/> TOTAL PACKAGES(IN WORDS) <hr/>			
Freight and charges			Place and date of issue Signed for the Carrier SHANGHAI OCEAN SHIPPING CO., LTD. 丁浩

*Applicable only when document used as a Through Bill of Lading

4、请根据以上资料缮制一般原产地证。（本题共 10 分）

（注：合同的信息必须是修正后的正确信息）

ORIGINAL

1.Exporter: (Exporter's business name, address, country)		Certificate No.		
2. Consignee: (Consignee's name, address, country)		CERTIFICATE OF ORIGIN OF THE PEOPLE'S REPUBLIC OF CHINA		
3. Means of transport and route:				
5. Country/ region of destination		5. For certifying authority use only		
6. Marks and numbers of Packages:	7.Number and kind of packages; description of goods:	8. H.S.Code	9. Gross weight or other quantity:	10. Number and date of invoices:
11. Declaration by the exporter :		12. <u>Certificate</u>		

<p>The undersigned hereby declares that the above details and statements are correct, that all the goods were produced in China and that they comply with the Rules of Origin of the People's Republic of China.</p> <p>HUNAN PROVINCIAL LIGHT INDUSTRIAL PRODUCTS I/E CORP</p> <p>湖南轻工产品进出口公司 李明远 (Authorized Signature)</p> <p>-----</p> <p>Place and date, signature of authorized Signatory</p>	<p>It is hereby certified on the basis of control carried out, that the declaration by the exporter is correct.</p>  <p>-----</p> <p>Place and date, signature and stamp of Certifying Authority</p>
---	--

(2) 实施条件

项目	基本实施条件	备注
场地	每个商务英语实训室配置 40 个操作台面和座位，每个实训室照明通风良好。	必备
设备	每个商务英语实训室配有 1 台服务器、40—50 台计算机，并安装 Office 办公软件，配置局域网。	必备
测评专家	每 40 名考生配备 1 名考评员。考评员要求具备至少二年以上从事国际贸易工作经验或二年以上外贸单证缮制实践教学指导经历。	必备

(3) 考核时量

考核时间：90 分钟

(4) 评分标准

模块总分	评价内容	配分	考核点	备注		
岗位核心 技能模块项 目二： 外贸单证 缮制 (总分 100 分，占总评 分的 50%)	职业素养 与 操作规范 (10分)	职业素养 (6分)	2分	(1) 具备外贸从业人员基本素质，认真严谨、耐心细致、恪守信誉、实事求是、服从安排，听从指挥、举止文明；	在考试过程中不服从安排、举止不得当者，记 0 分。	
			2分	具备对外贸合同及信用证信息甄别正误及修正能力、正确缮制单证能力，做到数据计算准确、信息填写正确、单据填写完整；	与所述能力及素养不符，扣 1-2 分。	
			2分	(3) 具备正确规范操作外贸电商平台能力，具有对外贸产品筛选关键信息的能力，符合外贸行业对外贸电商运营等相关岗位需求。	与所述能力及素养不符，扣 1-2 分。	
		操作规范 (4分)	2分	(1) 具备使用办公设备和 Office 办公软件的能力，在考核过程中以及考核结束后，不私自更换电脑、不随意关闭或重启电脑，没征求监考老师同意不随意提前或推迟交卷；	若私自更换电脑、随意关闭或重启电脑，记 0 分。	
			2分	(2) 能严格遵守企业 6S 管理要求（整理、整顿、清扫、清洁、素养、安全）。	若未遵守企业 6S 管理要求，记 0 分。	
		作品 (90分)	合同审核 (16分)	2分	(1) 买卖双方的名称与地址是否有误；	合同审核共 12 个考核点，有 8 处错误，每处 2 分，找出错误计 1 分，修正错误计 1 分。
				2分	(2) 品名、规格、数量、重量、单价是否有误；	
	2分			(3) 货物包装、体积是否有误；		
	2分			(4) 使用的贸易术语是否有误；		
	2分			(5) 合同金额和币种是否有误；		
	2分			(6) 合同中溢短装条款是否有误；		
	2分	(7) 唛头是否有误；				
	2分	(8) 起运港和目的港是否有误；				
2分	(9) 分批装运和转运是否有误；					

			2分	(10) 保险险别、保险金额是否有误;	
			2分	(11) 最迟装运期是否有误;	
			2分	(12) 汇票的付款期限是否有误。	
		装箱单缮制 (34分)	2分	(1) 进口商名称和地址: 拼写准确无误;	装箱单缮制部分共17个考核点, 每处计2分, 未填、错填每处扣2分。拼写错误每3处扣1分。
			2分	(2) 商业发票号码: 填写准确无误;	
			2分	(3) 商业发票开立日期: 填写准确无误;	
			2分	(4) 合同号码: 填写准确无误;	
			2分	(5) 装运港: 填写准确无误;	
			2分	(6) 目的港: 填写准确无误;	
			2分	(7) 唛头: 描述准确无误;	
			2分	(8) 货物描述及包装: 品名及规格信息填写准确无误, 计量数与外包装数关系表述准确无误;	
			2分	(9) 货物各自外包装总数量: 计算准确无误;	
			2分	(10) 货物各自总体积: 计算准确无误;	
			2分	(11) 货物各自总净重: 计算准确无误;	
			2分	(12) 货物各自总毛重: 计算准确无误;	
			2分	(13) 货物外包装总数量: 计算准确无误;	
			2分	(14) 货物总体积: 计算准确无误;	
			2分	(15) 货物总净重: 计算准确无误;	
			2分	(16) 货物总毛重: 计算准确无误;	
			2分	(17) 货物外包装总数量大写: 英文拼写正确。	
		提单缮制 (30分)	2分	(1) 发货人条款: 根据信用证中有关提单条款的规定进行正确的填写;	提单缮制部分共15个考核点, 每处计2分, 未填、错
			2分	(2) 收货人条款: 根据信用证中有关提单	

				条款的规定进行正确的填写;	填 每 处 扣 2 分。拼写错误每 3 处扣 1 分。
		2 分	(3) 通知人条款: 根据信用证中有关提单条款的规定进行正确的填写;		
		2 分	(4) 提单号码: 填写准确无误;		
		2 分	(5) 船名及船次: 填写准确无误;		
		2 分	(6) 装货港: 填写准确无误;		
		2 分	(7) 卸货港: 填写准确无误;		
		2 分	(8) 运费支付地点: 填写准确无误;		
		2 分	(9) 提单份数: 填写准确无误;		
		2 分	(10) 唛头: 填写准确无误;		
		2 分	(11) 货物描述条款: 包括货物的总称、包装的总数量等, 填写准确无误;		
		2 分	(12) 毛重条款: 计算准确无误, 单位描述正确;		
		2 分	(13) 体积条款: 计算准确无误, 单位描述正确;		
		2 分	(14) 包装总数量: 填写准确无误;		
		2 分	(15) 提单签发地点及日期: 填写准确无误。		
		产地证缮制 (10 分)	1 分	(1) 原产地证书编号: 填写准确无误;	
			1 分	(2) 发货方: 名称、详细地址及国家(地区), 拼写准确无误;	
			1 分	(3) 收货方: 最终收货方的名称、详细地址及国家(地区), 拼写准确无误;	
			1 分	(4) 运输方式及路线: 起运港、目的港及运输方式, 填写准确无误;	
			1 分	(5) 目的地国家(地区): 货物抵达的最	

				终进口国（地区），填写准确无误；	
			1分	(6) 唛头：填写准确无误；	
			1分	(7) 包装数量及种类、货物描述：拼写正确，并在末行加上截止线；	
			1分	(8) 海关代码（一般原产地证）、原产地标准（普惠制产地证 Form A）：填写准确无误；	
			1分	(9) 所有商品总毛重或者其他数量：数量计算准确。	
			1分	(10) 发票的号码和开立日期：填写准确无误。	

9. 试题编号：2-2-9 合同审核、单证缮制

(1) 任务描述

任务 1：合同审核

读懂谈判备忘录的内容；读懂并审核合同各条款；修改合同中的问题条款。

注意：考试资料中的合同为错误的合同，考试中涉及到合同的信息必须参考修改正确后的合同信息，否则造成的制单错误将不计分。

任务 2：装箱单缮制

分析合同中涉及装箱单缮制的相关条款；准确缮制装箱单；确保缮制的装箱单与合同的条款一致。

任务 3：提单缮制

分析合同的装运条款；准确缮制提单；确保缮制的提单与合同的条款一致。

任务 4：产地证缮制

分析合同中涉及产地证缮制的相关条款；准确缮制产地证；确保缮制的产地证与合同的条款一致。

背景资料

1、出口方基本情况

Company	HUNAN CEREALS, OILS AND FOODSTUFFS IMP. & EXP. GROUP CORP. LTD.
Url	http://www.hunancof.com/
Office Address	NO. 2 ZHUYUAN RD, CHANGSHA, HUNAN, CHINA
Zip code	410011
Phone	86-731-82280772
Fax	86-731-82289135
E-mail	Lixiang55@hunancof.com

2、进口方基本情况

Company	KRAFT FOODS COMPANY
Url	http://www.kraftfoodscompany.com/home/index.aspx
Office Address	135 LONGWAY STREET, MONTREAL 15122, CANADA
Tollfree	无
Phone	001-514-662 4782
Fax	001-514-662 4799

3、谈判备忘录

Minutes of a Meeting	
TIME:	Mar. 5-7, 2022
PLACE:	Conference Room of China Hotel, Guangzhou, Guangdong, China
PURPOSE:	To come to an agreement over the transaction of the interested product

PRESIDING:	Mr. Zhanghua (Party A: Sales Manager of Hunan Cereals, Oils and Foodstuffs Imp. & Exp. Group Corp. Ltd.)
PRESENT:	Mr. Robert Brisko (Party B: Purchasing Manager of Kraft Foods Company)

SUMMARY OF THE MEETING

After several rounds of negotiation, Party A and Party B come to terms on March 7 over the transaction of 1,000 mt White Garlic. A brief summary of the meeting is as follows:

1. Name of commodity and specifications:
WHITE GARLIC
PURE WHITE SKIN, NICE APPEARANCE
SIZE: 4.5CM, 5.0CM, 5.5CM, 6.0CM, 6.5CM AND UP
2. Packing: To be packed in 50KGS/BAG.
3. Weight and measurement:
G.W.: 50.5 KGS/BAG
N.W.: 50 KGS/BAG
MEAS: 0.02 CBM/BAG
4. Shipping marks: MONTREAL

G.W.: 50.5KGS

N.W.: 50KGS

ORIGIN: CHINA
5. Unit price and quantity: USD 800.00/mt CFR Montreal, 1,000 mt
6. Time and terms of shipment:
To be shipped no later than April 15, 2022.
Transshipment is allowed, but partial shipment is not allowed.
7. Ports of loading and destination: From Guangzhou to Montreal
8. Insurance: To be covered against All Risks and S.R.C.C.
9. Terms of payment: D/P AT SIGHT
10. Documents:
 - Commercial Invoice in triplicate.
 - Packing List in triplicate
 - Full set of clean on board ocean bills of lading, made out to order of shipper and blank endorsed and marked "freight prepaid" and notify the buyer.
 - Shipping advice must be sent to buyer on the date of shipment advising shipping marks, commodity name, carton numbers, total gross weight, vessel name, bill of lading No., port of loading, destination, contract No. and invoice No.
 - Certificate of Origin in duplicate.
 - Insurance policy/certificate blank endorsed covering all risks and S.R.C.C. for 110% of the total invoice value.

4、合同

销售合同

SALES CONTRACT

SELLER: HUNAN CEREALS, OILS AND FOODSTUFFS IMP. & **NO.:** HCOF-160307
 EXP. GROUP CORP. LTD. **DATE:** MAR. 07, 2022
 NO. 2 ZHUYUAN RD, CHANGSHA, HUNAN, **SIGNED IN:** GUANGZHOU
 CHINA
BUYER: KRAFT FOODS COMPANY
 130 LONGWAY STREET, MONTREAL 15122. CANADA

This contract is made by and agreed between the BUYER and SELLER, in accordance with the terms and conditions stipulated below.

1. Commodity & Specification	2. Quantity	3. Unit Price & Trade Terms	4. Amount
CIF MONTREAL			
WHITE GARLIC PURE WHITE SKIN, NICE APPEARANCE SIZE: 4.5CM, 5.0CM, 5.5CM, 6.0CM, 6.5CM AND UP	1,000 MT	USD 600.00/MT	USD 800,000.00
Total:	10,000 MT		USD 800,000.00

5. Total Value SAY U.S. DOLLARS EIGHT HUNDRED THOUSAND ONLY.

6. Packing G.W: 50.5 KGS/BAG
 N.W: 50 KGS/BAG
 MEAS: 0.02 CBM/BAG
 PACKED IN 20,000 BAGS

7. Shipping Marks MONTREAL
 G.W.: 50.5KGS
 N.W.: 50KGS
 ORIGIN: CHINA

8. Time of Shipment & means of Transportation BE EFFECTED BEFORE MARCH 15, 2022 FROM GUANGZHOU TO MONTREAL WITH PARTIAL SHIPMENT NOT ALLOWED TO AND TRANSSHIPMENT ALLOWED.

9. Port of Loading & FROM: SHENZHEN

- Destination** TO: MONTREAL
- 10. Insurance** THE SELLER SHALL ASSIST THE BUYER IN COVERING THE GOODS AGAINST S.R.C.C. FOR 110% OF THE TOTAL INVOICE VALUE AS PER THE RELEVANT OCEAN MARINE CARGO OF P.I.C.C. DATED 1/1/1981
- 11. Terms of Payment** TO BE MADE BY L/C 5 DAYS PRIOR TO SHIPMENT
- 12. Remarks**

The Buyer
KRAFT FOODS COMPANY

The Seller
HUNAN CEREALS, OILS AND
FOODSTUFFS IMP. & EXP. GROUP
CORP. LTD.

(signature)

(signature)

5、相关资料

- (1) INVOICE NO.: HNLY16315
- (2) INVOICE DATE: MARCH 15, 2022
- (3) PACKING

G. W.(KGS/BAG)	N. W.(KGS/BAG)	MEAS (CBM/BAG)
50.5	50	0.02

PACKED IN 20,000 BAGS

TOTAL EIGHT 40' CONTAINERS

- (4) VESSEL: JIE FANG 115B
- (5) B/L NO.: COSCO2875890
- (6) B/L DATE: APRIL 5, 2022
- (7) POLICY NO.: CR101736
- (8) CERTIFICATE NO.: 20220317
- (9) H.S. CODE: 0703201010
- (10) COLLECTING BANK: BANK OF CHINA, HUNAN BRANCH

抽考试题

SAY TOTAL :

HUNAN CEREALS, OILS AND FOODSTUFFS IMP. & EXP. GROUP CORP. LTD.

湖南粮油食品进出口集团公司

王伶俐

(Authorized Signature)

3、请根据以上资料缮制提单。(本题共 30 分)

(注: 合同的信息必须是修正后的正确信息)

Shipper		BILL OF LADING B/L NO.: 中国远洋运输公司 CHINA OCEAN SHIPPING ORIGINAL	
Consignee or order			
Notify Party			
*Pre carriage by	*Place of Receipt		
Ocean Vessel Voy. No.	Port of Loading		
Port of discharge	*Final destination	Freight payable at	Number original Bs/L
Marks and Numbers	Number and kind of packages; Description	Gross weight	Measurement m ³

TOTAL PACKAGES(IN WORDS)	
Freight and charges	
	Place and date of issue
	Signed for the Carrier GUANGZHOU OCEAN SHIPPING CO., LTD. 凌风

*Applicable only when document used as a Through Bill of Lading

- 4、请根据以上资料缮制一般原产地证。（本题共 10 分）
（注：合同的信息必须是修正后的正确信息）

ORIGINAL

1.Exporter: (Exporter's business name, address, country)		Certificate No.		
2. Consignee: (Consignee's name, address, country)		CERTIFICATE OF ORIGIN OF THE PEOPLE'S REPUBLIC OF CHINA		
3. Means of transport and route:				
6. Country/ region of destination		5. For certifying authority use only		
6. Marks and numbers of Packages:	7.Number and kind of packages; description of goods:	8. H.S.Code	9. Gross weight or other quantity:	10. Number and date of invoices:

<p>11. Declaration by the exporter :</p> <p>The undersigned hereby declares that the above details and statements are correct, that all the goods were produced in China and that they comply with the Rules of Origin of the People's Republic of China.</p> <p>HUNAN CEREALS, OILS AND FOODSTUFFS IMP. & EXP. GROUP CORP. LTD</p> <p>湖南粮油食品进出口集团公司 王伶俐</p> <p>(Authourized Signature)</p> <p>-----</p> <p>Place and date, signature of authorized Signatory</p>		<p>12. Certificate</p> <p>It is hereby certified on the basis of control carried out, that the declaration by the exporter is correct.</p>  <p>-----</p> <p>Place and date, signature and stamp of Certifying Authority</p>		

(2) 实施条件

项目	基本实施条件	备注
场地	每个商务英语实训室配置 40 个操作台面和座位，每个实训室照明通风良好。	必备
设备	每个商务英语实训室配有 1 台服务器、40—50 台计算机，并安装 Office 办公软件，配置局域网。	必备
测评专家	每 40 名考生配备 1 名考评员。考评员要求具备至少二年以上从事国际贸易工作经验或二年以上外贸单证缮制实践教学指导经历。	必备

(3) 考核时量

考核时间：90 分钟

(4) 评分标准

模块总分	评价内容	配分		考核点	备注
岗位核心 技能模块项 目二： 外贸单证 缮制 (总分 100 分，占总评 分的 50%)	职业素养 与 操作规范 (10 分)	职业素养 (6 分)	2 分	(1) 具备外贸从业人员基本素质，认真严谨、耐心细致、恪守信誉、实事求是、服从安排，听从指挥、举止文明；	在考试过程中不服从安排、举止不得当者，记 0 分。
			2 分	具备对外贸合同及信用证信息甄别正误及修正能力、正确缮制单证能力，做到数据计算准确、信息填写正确、单据填写完整；	与所述能力及素养不符，扣 1-2 分。
			2 分	(3) 具备正确规范操作外贸电商平台能力，具有对外贸产品筛选关键信息的能力，符合外贸行业对外贸电商运营等相关岗位需求。	与所述能力及素养不符，扣 1-2 分。
		操作规范 (4 分)	2 分	(1) 具备使用办公设备和 Office 办公软件的能力，在考核过程中以及考核结束后，不私自更换电脑、不随意关闭或重启电脑，没征求监考老师同意不随意提前或推迟交卷；	若私自更换电脑、随意关闭或重启电脑，记 0 分。
			2 分	(2) 能严格遵守企业 6S 管理要求（整理、整顿、清扫、清洁、素养、安全）。	若未遵守企业 6S 管理要求，记 0 分。
			合同审核 (16 分)		2 分
			2 分	(2) 品名、规格、数量、重量、单价是否有误；	
			2 分	(3) 货物包装、体积是否有误；	
			2 分	(4) 使用的贸易术语是否有误；	
			2 分	(5) 合同金额和币种是否有误；	
			2 分	(6) 合同中溢短装条款是否有误；	

		2分	(7) 唛头是否有误；	
		2分	(8) 起运港和目的港是否有误；	
		2分	(9) 分批装运和转运是否有误；	
		2分	(10) 保险险别、保险金额是否有误；	
		2分	(11) 最迟装运期是否有误；	
		2分	(12) 汇票的付款期限是否有误。	
	装箱单 缮制 (34分)	2分	(1) 进口商名称和地址：拼写准确无误；	装箱单缮制部分共 17 个考核点，每处计 2 分，未填、错填每处扣 2 分。拼写错误每 3 处扣 1 分。
		2分	(2) 商业发票号码：填写准确无误；	
		2分	(3) 商业发票开立日期：填写准确无误；	
		2分	(4) 合同号码：填写准确无误；	
		2分	(5) 装运港：填写准确无误；	
		2分	(6) 目的港：填写准确无误；	
		2分	(7) 唛头：描述准确无误；	
		2分	(8) 货物描述及包装：品名及规格信息填写准确无误，计量数与外包装数关系表述准确无误；	
		2分	(9) 货物各自外包装总数量：计算准确无误；	
		2分	(10) 货物各自总体积：计算准确无误；	
		2分	(11) 货物各自总净重：计算准确无误；	
2分	(12) 货物各自总毛重：计算准确无误；			
2分	(13) 货物外包装总数量：计算准确无误；			
2分	(14) 货物总体积：计算准确无误；			
2分	(15) 货物总净重：计算准确无误；			
2分	(16) 货物总毛重：计算准确无误；			
2分	(17) 货物外包装总数量大写：英文拼写正			

				确。	
		提单缮制 (30分)	2分	(1) 发货人条款：根据信用证中有关提单条款的规定进行正确的填写；	提单缮制部分共15个考核点，每处计2分，未填、错填每处扣2分。拼写错误每3处扣1分。
			2分	(2) 收货人条款：根据信用证中有关提单条款的规定进行正确的填写；	
			2分	(3) 通知人条款：根据信用证中有关提单条款的规定进行正确的填写；	
			2分	(4) 提单号码：填写准确无误；	
			2分	(5) 船名及船次：填写准确无误；	
			2分	(6) 装货港：填写准确无误；	
			2分	(7) 卸货港：填写准确无误；	
			2分	(8) 运费支付地点：填写准确无误；	
			2分	(9) 提单份数：填写准确无误；	
			2分	(10) 唛头：填写准确无误；	
			2分	(11) 货物描述条款：包括货物的总称、包装的总数量等，填写准确无误；	
			2分	(12) 毛重条款：计算准确无误，单位描述正确；	
			2分	(13) 体积条款：计算准确无误，单位描述正确；	
			2分	(14) 包装总数量：填写准确无误；	
			2分	(15) 提单签发地点及日期：填写准确无误。	
		产地证缮制 (10分)	1分	(1) 原产地证书编号：填写准确无误；	产地证缮制部分共10个考核点，每处计1分，未填、错填每处扣1分。拼写错误
			1分	(2) 发货方：名称、详细地址及国家（地区），拼写准确无误；	
			1分	(3) 收货方：最终收货方的名称、详细地址及国家（地区），拼写准确无误；	

			1分	(4) 运输方式及路线：起运港、目的港及运输方式，填写准确无误；	每3处扣1分。
			1分	(5) 目的地国家（地区）：货物抵达的最终进口国（地区），填写准确无误；	
			1分	(6) 唛头：填写准确无误；	
			1分	(7) 包装数量及种类、货物描述：拼写正确，并在末行加上截止线；	
			1分	(8) 海关代码（一般原产地证）、原产地标准（普惠制产地证 Form A）：填写准确无误；	
			1分	(9) 所有商品总毛重或者其他数量：数量计算准确。	
			1分	(10) 发票的号码和开立日期：填写准确无误。	

10. 试题编号：2-2-10 合同审核、单证缮制

(1) 任务描述

任务 1：合同审核

读懂谈判备忘录的内容；读懂并审核合同各条款；修改合同中的问题条款。

注意：考试资料中的合同为错误的合同，考试中涉及到合同的信息必须参考修改正确后的合同信息，否则造成的制单错误将不计分。

任务 2：装箱单缮制

分析合同中涉及装箱单缮制的相关条款；准确缮制装箱单；确保缮制的装箱单与合同的条款一致。

任务 3：提单缮制

分析合同的装运条款；准确缮制提单；确保缮制的提单与合同的条款一致。

任务 4：产地证缮制

分析合同中涉及产地证缮制的相关条款；准确缮制产地证；确保缮制的产地证与合同的条款一致。

背景资料

1、出口方基本情况

Company	BROAD AIR QUALITY TECHNOLOGY GROUP
Url	http://www.broad.com:8089/english/
Office Address	YUANDA TOWN, YUANDA 3RD ROAD, CHANGSHA, HUNAN, CHINA
Zip code	410138
Phone	86-731-84086688
Fax	86-731-84610087
E-mail	international@broad.net

2、进口方基本情况

Company	REACH COOLING GROUP
Url	http://www.reachcooling.com/
Office Address	625 E 10TH AVENUE HIAEAH, FLORIDA, U.S.A.
Tollfree	无
Phone	305-863-6360
Fax	305-887-9741

3、谈判备忘录

Minutes of a Meeting	
TIME:	May 20-25, 2022

PLACE:	Conference Room of Xiangjiang Hotel, Changsha, Hunan, China
PURPOSE:	To come to an agreement over the transaction of the interested products.
PRESIDING:	Mr. Zhanghui (Party A: Sales Manager of Broad Air Quality Technology Group)
PRESENT:	Mr. Cott Madson (Party B: Purchasing Manager of Reach Cooling Group)

SUMMARY OF THE MEETING

After several rounds of negotiation, Party A and Party B come to terms on May 25 over the transaction of Broad Air Condition Indoor Unit. A brief summary of the meeting is as follows:

1. Name of commodity and specifications:

Broad Air Condition Indoor Unit

Model FLAT DC3.6

Model OVAL DQ5.4

HORIZONTAL LONG-RANGE DE12

2. Packing: Each product shall be packed in 1carton of 1plastic bag. All in 27 cartons.

3. Weight and measurement:

G. W.: 370 KGS/CTN

N. W.: 340 KGS/CTN

MEAS: 1.0×0.9×0.9 CBM

PACKED IN 27 CARTONS

4. Shipping marks: REACH

BRA10478-23

NO. 1-27

5. Unit price and quantity: CIF MIAMI

FLAT DC3.6	USD 3,100.00/UNIT	15 units
------------	-------------------	----------

OVAL DQ5.4	USD 5,100.00/UNIT	2 units
------------	-------------------	---------

HORIZONTAL LONG-RANGE DE12	USD 5,500.00/UNIT	10 units
----------------------------	-------------------	----------

6. Time and terms of shipment:

To be shipped within 60 days after the contract is signed.

Transshipment is allowed, but partial shipment is not allowed.

7. Ports of loading and destination: From Guangzhou to Miami

8. Insurance: To be covered against all risks and S.R.C.C.

9. Terms of payment: 20% by T/T as prepayment and 80% by D/P at sight

10. Documents:

- Commercial Invoice in triplicate.
- Packing List in duplicate.
- Full set of clean on board ocean bills of lading, made out to order of shipper and blank endorsed and marked "freight prepaid" and notify the buyer.
- Shipping advice must be sent to buyer on the date of shipment advising shipping marks, commodity name, carton numbers, total gross weight, vessel name, bill of lading No., port of loading, destination, contract No. and invoice No.
- Certificate of Origin in duplicate.
- Insurance policy/certificate blank endorsed covering all risks and S.R.C.C. for 110% of the total invoice value.

4、合同

销售合同

SALES CONTRACT

SELLER: BROAD AIR QUALITY TECHNOLOGY GROUP **NO.:** BRA10478-23
YUANDA TOWN, YUANDA 3RD ROAD, **DATE:** MAY 25, 2022
CHANGSHA, HUNAN, CHINA **SIGNED IN:** CHANGSHA

BUYER: REACH COOLING GROUP
625 D 10TH AVENUE HIAEAH, FLORIDA, U.S.A.

This contract is made by and agreed between the BUYER and SELLER, in accordance with the terms and conditions stipulated below.

1. Commodity & Specification	2. Quantity	3. Unit Price & Trade Terms	4. Amount
			CIF MIAMI

BROAD AIR CONDITION INDOOR UNIT			
FLAT DC3.6	15 UNITS	USD 3,000.00/UNIT	USD 46,500.00
OVAL DQ5.4	2 UNITS	USD 5,100.00/UNIT	USD 10,200.00
HORIZONTAL LONG-RANGE DE12	10 UNITS	USD 5,500.00/UNIT	USD 55,000.00
Total:	25 UNITS		USD110,700.00

5. Total Value SAY U.S. DOLLARS ONE HUNDRED AND ELEVEN THOUSAND SEVEN HUNDRED ONLY.

6. Packing EACH PRODUCT SHALL BE PACKED IN A PLASTIC BAG AND EACH BAG IN AN OVERLAP SLOTTED WATERPROOF CARTON. ALL IN 27 CARTONS.

7. Shipping Marks REACHO
BRA10478-23
NO.1-27

8. Date of Shipment & means of Transportation TO BE EFFECTED BEFORE JUNE 30, 2022 FROM GUANGZHOU TO MIAMI WITH PARTIAL SHIPMENT NOT ALLOWED AND TRANSSHIPMENT NOT ALLOWED.

9. Port of Loading & Destination FROM: GUANGZHOU
TO: NEW YORK

10. Insurance THE SELLER SHALL COVER THE GOODS AGAINST ALL RISKS AND S.R.C.C. FOR 110% OF THE TOTAL INVOICE VALUE AS PER THE RELEVANT OCEAN MARINE CARGO OF P.I.C.C. DATED 1/1/1981

11. Terms of Payment 20% BY T/T AS PREPAYMENT AND 80% BY D/P AT SIGHT

12. Remarks

The Buyer
REACH COOLING GROUP

(signature)

The Seller
BROAD AIR QUALITY
TECHNOLOGY
GROUP

(signature)

5、相关资料

- (1) INVOICE NO.: BR16927-376
- (2) INVOICE DATE: JUNE 25, 2022
- (3) PACKING G. W.: 370 KGS/CTN
N. W.: 340 KGS/CTN
MEAS: 1.0×0.9×0.9 CBM

PACKED IN 27 CARTONS

TOTAL ONE 20' CONTAINER

(4) VESSEL: SEAWIND 8

(5) B/L NO.: COS1007201

(6) B/L DATE: JULY 20, 2022

(7) POLICY NO.: PICC09342

(8) CERTIFICATE NO.: 20220626

(9) H.S. CODE: 8415101000

(10) COLLECTING BANK: BANK OF CHINA, HUNAN BRANCH

抽考试题

1、请根据考试资料中的谈判备忘录 3 审核错误的合同 4，指出不符之处并修正。

(本题共 16 分)

1. _____
2. _____
3. _____
4. _____
5. _____
6. _____
7. _____
8. _____

2、请根据以上资料缮制装箱单。(本题共 34 分)

(注：合同的信息必须是修正后的正确信息)

远大集团

Broad Air Quality Technology Group

Yunda Town, Yuanda 3rd Road, Changsha, Hunan, China

TEL: 86-731-84086688 FAX: 86-731-84610087

装箱单

PACKING LIST

TO:

INVOICE NO.:

DATE:

S/C NO.:

FROM:

TO:

MARKS & NO.	DESCRIPTION S & PACKING	QTY	MEAS (M³)	N.W. (KGS)	G.W. (KGS)
Total:					

SAY TOTAL :

BROAD AIR QUALITY TECHNOLOGY GROUP

远大集团

陈洁

.....
(Authorized Signature)

3、请根据以上资料缮制提单。（本题共 30 分）

（注：合同的信息必须是修正后的正确信息）

Shipper	
Consignee or order	
Notify Party	
*Pre carriage by	*Place of Receipt

BILL OF LADING

B/L NO.:

中国远洋运输公司

CHINA OCEAN SHIPPING

ORIGINAL

Ocean Vessel Voy. No.	Port of Loading		
Port of discharge	*Final destination	Freight payable at	Number original Bs/L
Marks and Numbers	Number and kind of packages; Description	Gross weight	Measurement m³
TOTAL PACKAGES(IN WORDS)			
Freight and charges			
			Place and date of issue
			Signed for the Carrier GUANGZHOU OCEAN SHIPPING CO., LTD. 凌风

*Applicable only when document used as a Through Bill of Lading

4、请根据以上资料缮制一般原产地证。（本题共 10 分）
（注：合同的信息必须是修正后的正确信息）

ORIGINAL

1.Exporter: (Exporter's business name, address, country)	Certificate No.
	CERTIFICATE OF ORIGIN

2. Consignee: (Consignee's name, address, country)		OF THE PEOPLE'S REPUBLIC OF CHINA		
3. Means of transport and route:		5. For certifying authority use only		
7. Country/ region of destination				
6. Marks and numbers of Packages:	7. Number and kind of packages; description of goods:	8. H.S.Code	9. Gross weight or other quantity:	10. Number and date of invoices:
11. Declaration by the exporter : The undersigned hereby declares that the above details and statements are correct, that all the goods were produced in China and that they comply with the Rules of Origin of the People's Republic of China. <div style="text-align: center;"> BROAD AIR QUALITY TECHNOLOGY GROUP 远大集团 陈洁 (Authorized Signature) </div>		12. Certificate It is hereby certified on the basis of control carried out, that the declaration by the exporter is correct. <div style="text-align: center;">  </div>		

Place and date, signature of authorized Signatory	Place and date, signature and stamp of Certifying Authority
---	---

(2) 实施条件

项目	基本实施条件	备注
场地	每个商务英语实训室配置 40 个操作台面和座位，每个实训室照明通风良好。	必备
设备	每个商务英语实训室配有 1 台服务器、40—50 台计算机，并安装 Office 办公软件，配置局域网。	必备
测评专家	每 40 名考生配备 1 名考评员。考评员要求具备至少二年以上从事国际贸易工作经验或二年以上外贸单证缮制实践教学指导经历。	必备

(3) 考核时量

考核时间：90 分钟

(4) 评分标准

模块总分	评价内容	配分	考核点	备注	
岗位核心技能模块项目二：外贸单证缮制 (总分 100 分，占总评分的 50%)	职业素养与操作规范 (10 分)	职业素养 (6 分)	2 分	(1) 具备外贸从业人员基本素质，认真严谨、耐心细致、恪守信誉、实事求是、服从安排，听从指挥、举止文明；	在考试过程中不服从安排、举止不得当者，记 0 分。
			2 分	具备对外贸合同及信用证信息甄别正误及修正能力、正确缮制单证能力，做到数据计算准确、信息填写正确、单据填写完整；	与所述能力及素养不符，扣 1-2 分。
			2 分	(3) 具备正确规范操作外贸电商平台能力，具有对外贸产品筛选关键信息的能力，符合外贸行业对外贸电商运营等相关岗位需求。	与所述能力及素养不符，扣 1-2 分。

作品 (90分)	操作规范 (4分)	2分	(1) 具备使用办公设备和 Office 办公软件的能力,在考核过程中以及考核结束后,不私自更换电脑、不随意关闭或重启电脑,没征求监考老师同意不随意提前或推迟交卷;	若私自更换电脑、随意关闭或重启电脑,记0分。
		2分	(2) 能严格遵守企业 6S 管理要求(整理、整顿、清扫、清洁、素养、安全)。	若未遵守企业 6S 管理要求,记0分。
	合同审核 (16分)	2分	(1) 买卖双方的名称与地址是否有误;	合同审核共12个考核点,有8处错误,每处2分,找出错误计1分,修正错误计1分。
		2分	(2) 品名、规格、数量、重量、单价是否有误;	
		2分	(3) 货物包装、体积是否有误;	
		2分	(4) 使用的贸易术语是否有误;	
		2分	(5) 合同金额和币种是否有误;	
		2分	(6) 合同中溢短装条款是否有误;	
		2分	(7) 唛头是否有误;	
		2分	(8) 起运港和目的港是否有误;	
		2分	(9) 分批装运和转运是否有误;	
		2分	(10) 保险险别、保险金额是否有误;	
		2分	(11) 最迟装运期是否有误;	
		2分	(12) 汇票的付款期限是否有误。	
装箱单缮制 (34分)	2分	(1) 进口商名称和地址: 拼写准确无误;	装箱单缮制部分共17个考核点,每处计2分,未填、错填每处扣2分。拼写错误每3处扣1分。	
	2分	(2) 商业发票号码: 填写准确无误;		
	2分	(3) 商业发票开立日期: 填写准确无误;		
	2分	(4) 合同号码: 填写准确无误;		
	2分	(5) 装运港: 填写准确无误;		
	2分	(6) 目的港: 填写准确无误;		
	2分	(7) 唛头: 描述准确无误;		

			2分	(8) 货物描述及包装：品名及规格信息填写准确无误，计量数与外包装数关系表述准确无误；	
			2分	(9) 货物各自外包装总数量：计算准确无误；	
			2分	(10) 货物各自总体积：计算准确无误；	
			2分	(11) 货物各自总净重：计算准确无误；	
			2分	(12) 货物各自总毛重：计算准确无误；	
			2分	(13) 货物外包装总数量：计算准确无误；	
			2分	(14) 货物总体积：计算准确无误；	
			2分	(15) 货物总净重：计算准确无误；	
			2分	(16) 货物总毛重：计算准确无误；	
			2分	(17) 货物外包装总数量大写：英文拼写正确。	
		提单缮制 (30分)	2分	(1) 发货人条款：根据信用证中有关提单条款的规定进行正确的填写；	提单缮制部分共15个考核点，每处计2分，未填、错填每处扣2分。拼写错误每3处扣1分。
			2分	(2) 收货人条款：根据信用证中有关提单条款的规定进行正确的填写；	
			2分	(3) 通知人条款：根据信用证中有关提单条款的规定进行正确的填写；	
			2分	(4) 提单号码：填写准确无误；	
			2分	(5) 船名及船次：填写准确无误；	
			2分	(6) 装货港：填写准确无误；	
			2分	(7) 卸货港：填写准确无误；	
			2分	(8) 运费支付地点：填写准确无误；	
			2分	(9) 提单份数：填写准确无误；	

			2分	(10) 唛头: 填写准确无误;	
			2分	(11) 货物描述条款: 包括货物的总称、包装的总数量等, 填写准确无误;	
			2分	(12) 毛重条款: 计算准确无误, 单位描述正确;	
			2分	(13) 体积条款: 计算准确无误, 单位描述正确;	
			2分	(14) 包装总数量: 填写准确无误;	
			2分	(15) 提单签发地点及日期: 填写准确无误。	
		产地证缮制 (10分)	1分	(1) 原产地证书编号: 填写准确无误;	产地证缮制部分共10个考核点, 每处计1分, 未填、错填每处扣1分。拼写错误每3处扣1分。
			1分	(2) 发货方: 名称、详细地址及国家(地区), 拼写准确无误;	
			1分	(3) 收货方: 最终收货方的名称、详细地址及国家(地区), 拼写准确无误;	
			1分	(4) 运输方式及路线: 起运港、目的港及运输方式, 填写准确无误;	
			1分	(5) 目的地国家(地区): 货物抵达的最终进口国(地区), 填写准确无误;	
			1分	(6) 唛头: 填写准确无误;	
			1分	(7) 包装数量及种类、货物描述: 拼写正确, 并在末行加上截止线;	
			1分	(8) 海关代码(一般原产地证)、原产地标准(普惠制产地证 Form A): 填写准确无误;	
			1分	(9) 所有商品总毛重或者其他数量: 数量计算准确。	
			1分	(10) 发票的号码和开立日期: 填写准确无误。	

11. 试题编号：2-2-11 合同审核、单证缮制

(1) 任务描述

任务 1：合同审核

读懂谈判备忘录的内容；读懂并审核合同各条款；修改合同中的问题条款。

注意：考试资料中的合同为错误的合同，考试中涉及到合同的信息必须参考修改正确后的合同信息，否则造成的制单错误将不计分。

任务 2：装箱单缮制

分析合同中涉及装箱单缮制的相关条款；准确缮制装箱单；确保缮制的装箱单与合同的条款一致。

任务 3：保险单缮制

分析合同的保险条款；准确缮制保险单；确保缮制的保险单与合同的条款一致。

任务 4：产地证缮制

分析合同中涉及产地证缮制的相关条款；准确缮制产地证；确保缮制的产地证与合同的条款一致。

背景资料

1、出口方基本情况

Company	BROAD AIR QUALITY TECHNOLOGY GROUP
Url	http://www.broad.com:8089/english/
Office Address	YUANDA TOWN, YUANDA 3RD ROAD, CHANGSHA, HUNAN, CHINA
Zip code	410138
Phone	86-731-84086688

Fax	86-731-84610087
E-mail	international@broad.net

2、进口方基本情况

Company	INNOVAIR CORPORATION
Url	http://www.innovair.com/
Office Address	AV. PAEO DE LA REFORMA NO. 350, PISO 11 COLONIA JUAREZ, MEXICO
Tollfree	无
Phone	(55) 9171-8465
Fax	无

3、谈判备忘录

Minutes of a Meeting	
TIME:	June 11-17, 2022
PLACE:	Conference Room of Hunan Hotel, Changsha, Hunan, China
PURPOSE:	To come to an agreement over the transaction of the interested products.
PRESIDING:	Mr. Zhanghui (Party A: Sales Manager of Broad Air Quality Technology Group)
PRESENT:	Mr. Maddox Tatem (Party B: Purchasing Manager of Innovair Corporation)
SUMMARY OF THE MEETING	
<p>After several rounds of negotiation, Party A and Party B come to terms on June 17 over the transaction of Broad Heat Meter. A brief summary of the meeting is as follows:</p>	
<p>1. Name of commodity and specifications:</p> <p style="padding-left: 40px;">Broad Heat Meter</p> <p style="padding-left: 40px;">Model BRL 15, Model BRL 25, Model BRL 40</p>	
<p>2. Packing: Each product shall be packed in 1 carton of 1 plastic bag. All in 200 cartons.</p>	
<p>3. Weight and measurement:</p>	

G. W.: 7.5 KGS/CTN

N. W.: 7.3 KGS/CTN

MEAS: 0.8×0.8×0.6 CBM

PACKED IN 200 CARTONS

4. Shipping marks: INNOVAIR

BR1098-76

NO. 1-200

5. Unit price and quantity: CIF MEXICO CITY

BRL 15 USD 40.00/PC 800 PCS

BRL 25 USD 60.00/PC 500 PCS

BRL 40 USD 50.00/PC 700 PCS

6. Time and terms of shipment:

To be shipped within 60 days after the contract is signed.

Transshipment is allowed, but partial shipment is not allowed.

7. Ports of loading and destination: From Guangzhou to Mexico City

8. Insurance: To be covered against F.P.A. and T.P.N.D.

9. Terms of payment: 20% by T/T as prepayment as prepayment and 80% by D/P at sight

10. Documents:

- Commercial Invoice in triplicate.
- Packing List in duplicate.
- Full set of clean on board ocean bills of lading, made out to order of shipper and blank endorsed and marked "freight prepaid" and notify the buyer.
- Shipping advice must be sent to buyer on the date of shipment advising shipping marks, commodity name, carton numbers, total gross weight, vessel name, bill of lading No., port of loading, destination, contract No. and invoice No.
- Certificate of Origin in duplicate.
- Insurance policy/certificate blank endorsed covering F.P.A. and T.P.N.D. for 110% of the total invoice value.

4、合同

销售合同

SALES CONTRACT

SELLER: BROAD AIR QUALITY TECHNOLOGY GROUP **NO.:** BR1098-76
 YUANDA TOWN, YUANDA 3RD ROAD, CHANGSHA, **DATE:** JUNE 20, 2021
 HUNAN, CHINA **SIGNED IN:** CHANGSHA

BUYER: INNOVAIR CORPORATION
 AV. PAEO DE LA REFORMA NO. 350, PISO 11 COLONIA JUAREZ, MEXICO

This contract is made by and agreed between the BUYER and SELLER, in accordance with the terms and conditions stipulated below.

1. Commodity & Specification	2. Quantity	3. Unit Price & Trade Terms	4. Amount
CFR MEXICO CITY			
BROAD HEAT METER	800 PCS	USD 40.00/PC	USD 32,000.00
BRL 15	500 PCS	USD 60.00/PC	USD 30,000.00
BRL 25	700 PCS	USD 50.00/PC	USD 35,000.00
BRL 04			
Total:	2000 PCS		USD 97,000.00

5. Total Value SAY U.S. DOLLARS NINETY THOUSAND ONLY

6. Packing EACH PRODUCT SHALL BE PACKED IN A PLASTIC BAG AND EACH TEN IN AN OVERLAP SLOTTED WATERPROOF CARTON. ALL IN 200 CARTONS.

7. Shipping Marks INNOVAIR
BR1098-77
NO.1-200

8. Date of Shipment & means of Transportation TO BE EFFECTED BEFORE SEPTEMBER 20, 2022 FROM GUANGZHOU TO MEXICOCITY WITH PARTIAL SHIPMENT NOT ALLOWED AND TRANSSHIPMENT ALLOWED.

9. Port of Loading & Destination FROM: SHENZHEN
TO: MEXICO CITY

10. Insurance THE SELLER SHALL COVER THE GOODS AGAINST F.P.A. AND T.P.N.D. FOR 110% OF THE TOTAL INVOICE VALUE AS PER THE RELEVANT OCEAN MARINE CARGO OF P.I.C.C. DATED 1/1/1981

11. Terms of Payment 20% BY T/T AS PREPAYMENT AND 80% BY D/P 30 DAYS AFTER SIGHT.

12. Remarks

The Buyer

The Seller

INNOVAIR CORPORATION

BROAD AIR QUALITY TECHNOLOGY

GROUP

(signature)

(signature)

5、相关资料

(1) INVOICE NO.: BR1097

(2) INVOICE DATE: JULY 15, 2022

(3) PACKING:

G. W.: 7.5 KGS/CTN

N. W.: 7.3 KGS/CTN

MEAS: 0.8×0.8×0.6 CBM

PACKED IN 200 CARTONS

TOTAL THREE 20' CONTAINERS

(4) VESSEL: TIANSHAN09

(5) B/L NO.: COS1012901

(6) B/L DATE: AUGUST 18, 2022

(7) POLICY NO.: PICC09231

(8) CERTIFICATE NO.: 20220716

(9) H.S. CODE: 9033000000

(10) COLLECTING BANK: BANK OF CHINA, HUNAN BRANCH

抽考试题

1、请根据考试资料中的谈判备忘录 3 审核错误的合同 4，指出不符之处并修正。

(本题共 16 分)

1. _____

2. _____

3. _____

4. _____

5. _____

6. _____

7. _____

The People's Insurance (Property) Company of China Ltd.

发票号码

保险单号次

Invoice No.

Policy No.

海 洋 货 物 运 输 保 险 单

MARINE CARGO TRANSPORTATION INSURANCE POLICY

被保险人

Insured:

中保财产保险有限公司(以下简称本公司)根据被保险人的要求,及其所缴付约定的保险费,按照本保险单承担的险别和背面所载条款与下列特别条款承保下列货物运输保险,特签发本保单。

This policy of Insurance witnesses that The People's Insurance (Property) Company of China, Ltd. (hereinafter called "The company"), at the request of the Insured and consideration of the premium paid to The Company, undertakes to insure the under-mentioned goods in transportation subject to the condition of this Policy as per the Clauses printed overleaf and other special clauses attached hereon.

保险货物项目 Description of Goods	包装、单位、数量 Packaging Unit Quantity	保险金额 Amount Insured

承保险别

货物标记

Condition

Marks of Goods

总保险金额:

Total Amount Insured

保费

运输工具

开航日期:

Premium As arranged **Per conveyance S.S**

Slg. On or abt

启运港

目的港

From

To

所保货物，如发生本保险合同单项下可能引起索赔的损失或损坏，应立即通知本公司下述代理人查勘，如有索赔，应向本公司提交保险单正本（本保险单共有 份正本）及有关文件。如一份正本已用于索赔，其余正本则自动失效。

In the event of loss or damage which may result in a claim under this Policy, immediate notice must be given to the Company's Agent as mentioned hereunder. Claims, if any, one of the Original Policy which has been issued in Original(s) together with the relevant documents shall be surrendered to the Company, if one of the Original Policy has been accomplished, the others to be void.

中保财产保险有限公司

The People's Insurance (Property) Company of China Ltd.

赔款偿付地点

Claim payable at

日期

Date

General Manager: 孙宁



地址:

Address:

- 4、请根据以上资料缮制一般原产地证。（本题共 10 分）
（注：合同的信息必须是修正后的正确信息）

ORIGINAL

1.Exporter: (Exporter's business name, address, country)	Certificate No.
2. Consignee: (Consignee's name, address, country)	CERTIFICATE OF ORIGIN OF THE PEOPLE'S REPUBLIC OF CHINA
3. Means of transport and route:	5. For certifying authority use only

8. Country/ region of destination				
6. Marks and numbers of Packages:	7. Number and kind of packages; description of goods:	8. H.S.Code	9. Gross weight or other quantity:	10. Number and date of invoices:
11. Declaration by the exporter : The undersigned hereby declares that the above details and statements are correct, that all the goods were produced in China and that they comply with the Rules of Origin of the People's Republic of China.   Place and date, signature of authorized Signatory		12. Certificate It is hereby certified on the basis of control carried out, that the declaration by the exporter is correct. Place and date, signature and stamp of Certifying Authority		

(2) 实施条件

项目	基本实施条件	备注

场地	每个商务英语实训室配置 40 个操作台面和座位，每个实训室照明通风良好。	必备
设备	每个商务英语实训室配有 1 台服务器、40—50 台计算机，并安装 Office 办公软件，配置局域网。	必备
测评专家	每 40 名考生配备 1 名考评员。考评员要求具备至少二年以上从事国际贸易工作经验或二年以上外贸单证缮制实践教学指导经历。	必备

(3) 考核时量

考核时间：90 分钟

(4) 评分标准

模块总分	评价内容	配分		考核点	备注
岗位核心技能模块项目二：外贸单证缮制 (总分 100 分，占总评分的 50%)	职业素养与操作规范 (10 分)	职业素养 (6 分)	2 分	(1) 具备外贸从业人员基本素质，认真严谨、耐心细致、恪守信誉、实事求是、服从安排，听从指挥、举止文明；	在考试过程中不服从安排、举止不得当者，记 0 分。
			2 分	具备对外贸合同及信用证信息甄别正误及修正能力、正确缮制单证能力，做到数据计算准确、信息填写正确、单据填写完整；	与所述能力及素养不符，扣 1-2 分。
			2 分	(3) 具备正确规范操作外贸电商平台能力，具有对外贸产品筛选关键信息的能力，符合外贸行业对外贸电商运营等相关岗位需求。	与所述能力及素养不符，扣 1-2 分。
		操作规范 (4 分)	2 分	(1) 具备使用办公设备和 Office 办公软件的能力，在考核过程中以及考核结束后，不私自更换电脑、不随意关闭或重启电脑，没征求监考老师同意不随意提前或推迟交卷；	若私自更换电脑、随意关闭或重启电脑，记 0 分。
			2 分	(2) 能严格遵守企业 6S 管理要求（整理、整顿、清扫、清洁、素养、安全）。	若未遵守企业 6S 管理要求，记 0 分。

	作品 (90分)	合同审核 (16分)	2分	(1) 买卖双方的名称与地址是否有误;	合同审核共 12个考核点, 有8处错误, 每处2分,找 出错误计1 分,修正错误 计1分。
			2分	(2) 品名、规格、数量、重量、单价是否有误;	
			2分	(3) 货物包装、体积是否有误;	
			2分	(4) 使用的贸易术语是否有误;	
			2分	(5) 合同金额和币种是否有误;	
			2分	(6) 合同中溢短装条款是否有误;	
			2分	(7) 唛头是否有误;	
			2分	(8) 起运港和目的港是否有误;	
			2分	(9) 分批装运和转运是否有误;	
			2分	(10) 保险险别、保险金额是否有误;	
			2分	(11) 最迟装运期是否有误;	
			2分	(12) 汇票的付款期限是否有误。	
		装箱单 缮制 (34分)	2分	(1) 进口商名称和地址: 拼写准确无误;	装箱单缮制部 分共17个考 核点,每处计 2分,未填、 错填每处扣2 分。拼写错误 每3处扣1分。
			2分	(2) 商业发票号码: 填写准确无误;	
			2分	(3) 商业发票开立日期: 填写准确无误;	
			2分	(4) 合同号码: 填写准确无误;	
			2分	(5) 装运港: 填写准确无误;	
			2分	(6) 目的港: 填写准确无误;	
			2分	(7) 唛头: 描述准确无误;	
			2分	(8) 货物描述及包装: 品名及规格信息填写准确无误,计量数与外包装数关系表述准确无误;	
			2分	(9) 货物各自外包装总数量: 计算准确无误;	
			2分	(10) 货物各自总体积: 计算准确无误;	
2分	(11) 货物各自总净重: 计算准确无误;				

			2分	(12) 货物各自总毛重: 计算准确无误;	
			2分	(13) 货物外包装总数量: 计算准确无误;	
			2分	(14) 货物总体积: 计算准确无误;	
			2分	(15) 货物总净重: 计算准确无误;	
			2分	(16) 货物总毛重: 计算准确无误;	
			2分	(17) 货物外包装总数量大写: 英文拼写正确。	
		保险单缮制 (30分)	2分	(1) 发票号码: 填写准确无误;	保险单缮制部分共15个考核点, 每处计2分, 未填、错填每处扣2分。拼写错误每3处扣1分。
			2分	(2) 保险单号次: 填写准确无误;	
			2分	(3) 被保险人公司名称和地址: 填写准确无误;	
			2分	(4) 被保险货物名称: 填写准确无误;	
			2分	(5) 外包装的数量和单位: 填写准确无误;	
			2分	(6) 保险金额阿拉伯数字小写: 计算准确无误, 填写正确;	
			2分	(7) 承保险别条款: 填写准确无误, 拼写正确;	
			2分	(8) 货物唛头: 填写准确无误;	
			2分	(9) 保险金额英文大写: 计算准确无误, 拼写正确;	
			2分	(10) 船名和航次: 填写准确无误;	
			2分	(11) 开航日期即提单日期: 填写准确无误;	
			2分	(12) 装运港: 填写准确无误;	
			2分	(13) 目的港: 填写准确无误;	
			2分	(14) 赔款偿付地点及币种: 填写准确无误;	

			2分	(15) 投保日期及地点: 填写准确无误.	
		产地证缮制 (10分)	1分	(1) 原产地证书编号: 填写准确无误;	产地证缮制部分共10个考核点, 每处计1分, 未填、错填每处扣1分。拼写错误每3处扣1分。
	1分		(2) 发货方: 名称、详细地址及国家(地区), 拼写准确无误;		
	1分		(3) 收货方: 最终收货方的名称、详细地址及国家(地区), 拼写准确无误;		
	1分		(4) 运输方式及路线: 起运港、目的港及运输方式, 填写准确无误;		
	1分		(5) 目的地国家(地区): 货物抵达的最终进口国(地区), 填写准确无误;		
	1分		(6) 唛头: 填写准确无误;		
	1分		(7) 包装数量及种类、货物描述: 拼写正确, 并在末行加上截止线;		
	1分		(8) 海关代码(一般原产地证)、原产地标准(普惠制产地证 Form A): 填写准确无误;		
	1分		(9) 所有商品总毛重或者其他数量: 数量计算准确。		
	1分		(10) 发票的号码和开立日期: 填写准确无误。		

12. 试题编号: 2-2-12 合同审核、单证缮制

(1) 任务描述

任务 1: 合同审核

读懂谈判备忘录的内容; 读懂并审核合同各条款; 修改合同中的问题条款。

注意: 考试资料中的合同为错误的合同, 考试中涉及到合同的信

息必须参考修改正确后的合同信息，否则造成的制单错误将不计分。

任务 2：装箱单缮制

分析合同中涉及装箱单缮制的相关条款；准确缮制装箱单；确保缮制的装箱单与合同的条款一致。

任务 3：保险单缮制

分析合同中的保险条款；准确缮制保险单；确保缮制的保险单与合同的条款一致。

任务 4：产地证缮制

分析合同中涉及产地证缮制的相关条款；准确缮制产地证；确保缮制的产地证与合同的条款一致。

背景资料

1、出口方基本情况

Company	BROAD AIR QUALITY TECHNOLOGY GROUP
Url	http://www.broad.com:8089/english/
Office Address	YUANDA TOWN, YUANDA 3RD ROAD, CHANGSHA, HUNAN, CHINA
Zip code	410138
Phone	86-731-84086688
Fax	86-731-84610087
E-mail	international@broad.net

2、进口方基本情况

Company	CLIMA TECH CORPORATION
Url	http://www.clima-tech.com/
Office Address	5308 56TH COMMERCE PARK BOULEVARD, TAMPA, U.S.A.
Tollfree	800-660-9755

Phone	(208) 377-9755
Fax	(208) 378-8075

3、谈判备忘录

Minutes of a Meeting	
TIME:	Mar. 17-25, 2022
PLACE:	Conference Room of Hunan Hotel, Changsha, Hunan, China
PURPOSE:	To come to an agreement over the transaction of the interested products.
PRESIDING:	Mr. Zhanghui (Party A: Sales Manager of Broad Air Quality Technology Group)
PRESENT:	Mr. Sala Sanow (Party B: Purchasing Manager of Clima Tech Corporation)
SUMMARY OF THE MEETING	
<p>After several rounds of negotiation, Party A and Party B come to terms on March 25 over the transaction of Broad X Vacuum Boiler & Tube Bg16. A brief summary of the meeting is as follows:</p>	
<p>1. Name of commodity and specifications: Broad X Vacuum Boiler & Tube Bg16</p>	
<p>2. Packing: Each product shall be packed in 1 case of 1 plastic bag. All in 3 cases.</p>	
<p>3. Weight and measurement:</p> <p style="padding-left: 40px;">G. W.: 5 MT/CASE</p> <p style="padding-left: 40px;">N. W.: 4.7 MT/CASE</p> <p style="padding-left: 40px;">MEAS: 2.4×1.8×1.5 CBM</p> <p style="padding-left: 40px;">PACKED IN 3 CASES</p>	
<p>4. Shipping marks: CLIMA TECH</p> <p style="padding-left: 80px;">BR110933</p> <p style="padding-left: 80px;">NO. 1-3</p>	
<p>5. Unit price and quantity: CIF LOS ANGELES</p> <p style="padding-left: 40px;">Broad X Vacuum Boiler & Tube Bg16 USD 4,250.00/SET 3 SETS</p>	
<p>6. Time and terms of shipment:</p>	

To be shipped within 60 days after the contract is signed.

Transshipment is allowed, but partial shipment is not allowed.

7. Ports of loading and destination: From Guangzhou to Los Angeles

8. Insurance: To be covered against F.P.A. and T.P.N.D.

9. Terms of payment: 20% by T/T as prepayment and 80% by D/P at sight

10. Documents:

- Commercial Invoice in triplicate.
- Packing List in triplicate.
- Full set of clean on board ocean bills of lading, made out to order of shipper and blank endorsed and marked "freight prepaid" and notify the buyer.
- Shipping advice must be sent to buyer on the date of shipment advising shipping marks, commodity name, carton numbers, total gross weight, vessel name, bill of lading No., port of loading, destination, contract No. and invoice No.
- Certificate of Origin in duplicate.
- Insurance policy/certificate blank endorsed covering F.P.A. and T.P.N.D. for 110% of the total invoice value.

4、合同

销售合同

SALES CONTRACT

SELLER: BROAD AIR QUALITY TECHNOLOGY GROUP **NO.:** BR110933
YUANDA TOWN, YUANDA 3RD ROAD, **DATE:** APR.1, 2022
CHANGSHA, HUNAN, CHINA **SIGNED IN:** CHANGSHA

BUYER: CLIMA TECH GROUP
5308 56TH COMMERCE PARK BOULEVARD, LOS ANGELES, U.S.A.

This contract is made by and agreed between the BUYER and SELLER, in accordance with the terms and conditions stipulated below.

1. Commodity & Specification	2. Quantity	3. Unit Price & Trade Terms	4. Amount
------------------------------	-------------	-----------------------------	-----------

CFR LOS ANGELES			
BROAD X VACUUM BOILER & TUBE BG16	2 SETS	USD 4,250.00/SET	USD 12,750.00
Total:	2 SETS		USD 12,700.00

- 5. Total Value** SAY U.S. DOLLARS TWELVE THOUSAND SEVEN HUNDRED AND FIFTY ONLY.
- 6. Packing** EACH PRODUCT SHALL BE PACKED IN A PLASTIC BAG AND EACH IN A WOODEN CASE. ALL IN 3 CASES.
- 7. Shipping Marks** CLIMA TECH
BR110922
NO.1-3
- 8. Date of Shipment & means of Transportation** & TO BE EFFECTED BEFORE APRIL 30, 2022 FROM GUANGZHOU TO LOS ANGELES WITH PARTIAL SHIPMENT NOT ALLOWED AND TRANSSHIPMENT ALLOWED.
- 9. Port of Loading & Destination** & FROM: GUANGZHOU
TO: NEW YORK
- 10. Insurance** THE SELLER SHALL COVER THE GOODS AGAINST F.P.A. AND T.P.N.D. FOR 120% OF THE TOTAL INVOICE VALUE AS PER THE RELEVANT OCEAN MARINE CARGO OF P.I.C.C. DATED 1/1/1981
- 11. Terms of Payment** 20% BY T/T AS PREPAYMENT AND 80% BY D/P AT SIGHT
- 12. Remarks**

The Buyer	The Seller
CLIMA TECH CORPORATION	BROAD AIR QUALITY TECHNOLOGY GROUP
(signature)	(signature)

5、相关资料

- (1) INVOICE NO.: BR1108UQ
- (2) INVOICE DATE: APRIL 15, 2022
- (3) PACKING:
 - G. W.: 5 MT/CASE
 - N. W.: 4.7 MT/CASE
 - MEAS: 2.4×1.8×1.5 CBM

PACKED IN 3 CASES

TOTAL ONE 20' CONTAINER

(4) VESSEL: TAISHAN 09

(5) B/L NO.: COS780QW

(6) B/L DATE: MAY 20, 2022

(7) POLICY NO.: PICC08WE31

(8) CERTIFICATE NO.: 20220416

(9) H.S. CODE: 7008001000

(10) COLLECTING BANK: BANK OF CHINA, HUNAN BRANCH

抽考试题

1、请根据考试资料中的谈判备忘录 3 审核错误的合同 4，指出不符之处并修正。

(本题共 16 分)

1. _____
2. _____
3. _____
4. _____
5. _____
6. _____
7. _____
8. _____

2、请根据以上资料缮制装箱单。(本题共 34 分)

(注：合同的信息必须是修正后的正确信息)

远大集团

Broad Air Quality Technology Group

Yunda Town, Yuanda 3rd Road, Changsha, Hunan, China

TEL: 86-731-84086688 FAX: 86-731-84610087

装箱单

PACKING LIST

TO:

INVOICE NO.:

DATE:

S/C NO.:

FROM:

TO:

MARKS & NO.	DESCRIPTION S & PACKING	QTY	MEAS (M³)	N.W. (KGS)	G.W. (KGS)
Total:					

SAY TOTAL :

BROAD AIR QUALITY TECHNOLOGY GROUP

远大集团

陈洁

.....
(Authorized Signature)

3、请根据以上资料缮制保险单。（本题共 30 分）

（注：合同的信息必须是修正后的正确信息）

中保财产保险有限公司

The People's Insurance (Property) Company of China Ltd.

发票号码

保险单号次

Invoice No.

Policy No.

海洋货物运输保险单

MARINE CARGO TRANSPORTATION INSURANCE POLICY

被保险人

Insured:

中保财产保险有限公司(以下简称本公司)根据被保险人的要求,及其所缴付约定的保险费,按照本保险单承担的险别和背面所载条款与下列特别条款承保下列货物运输保险,特签发本保单。

This policy of Insurance witnesses that The People's Insurance (Property) Company of China, Ltd. (hereinafter called "The company"), at the request of the Insured and consideration of the premium paid to The Company, undertakes to insure the under-mentioned goods in transportation subject to the condition of this Policy as per the Clauses printed overleaf and other special clauses attached hereon.

保险货物项目 Description of Goods	包装、单位、数量 Packing Unit Quantity	保险金额 Amount Insured

承保险别

货物标记

Condition

Marks of Goods

总保险金额:

Total Amount Insured

保费

运输工具

开航日期:

Premium As arranged **Per conveyance S.S**

Slg. On or abt

启运港

目的港

From

To

所保货物,如发生本保险合同单项下可能引起索赔的损失或损坏,应立即通知本公司下述代理人查勘,如有索赔,应向本公司提交保险单正本(本保险单共有 份正本)及有关文件。如一份正本已用于索赔,其余正本则自动失效。

In the event of loss or damage which may result in a claim under this Policy, immediate notice must be given to the Company's Agent as mentioned hereunder. Claims, if any, one of the Original Policy which has been issued in Original(s) together with the relevant documents shall be surrendered to the Company, if one of the Original Policy has been accomplished, the others to be void.

中保财产保险有限公司

The People's Insurance (Property) Company of China Ltd.

赔款偿付地点

Claim payable at

日期

Date

General Manager: 孙宁

地址:

Address:

- 4、请根据以上资料缮制一般原产地证。(本题共 10 分)
(注: 合同的信息必须是修正后的正确信息)

ORIGINAL

1.Exporter: (Exporter's business name, address, country)		Certificate No.		
		CERTIFICATE OF ORIGIN OF THE PEOPLE'S REPUBLIC OF CHINA		
2. Consignee: (Consignee's name, address, country)		5. For certifying authority use only		
3. Means of transport and route:				
9. Country/ region of destination		6. Marks and numbers of Packages:		
7.Number and kind of packages; description of goods:				
8. H.S.Code		9. Gross weight or other quantity:		10. Number and date of invoices:

<p>11. Declaration by the exporter :</p> <p>The undersigned hereby declares that the above details and statements are correct, that all the goods were produced in China and that they comply with the Rules of Origin of the People's Republic of China.</p> <p>BROAD AIR QUALITY TECHNOLOGY GROUP 远大集团 陈洁 (Authorized Signature)</p> <p>.....</p> <p>Place and date, signature of authorized Signatory</p>		<p>12. Certificate</p> <p>It is hereby certified on the basis of control carried out, that the declaration by the exporter is correct.</p>  <p>.....</p> <p>Place and date, signature and stamp of Certifying Authority</p>		

(2) 实施条件

项目	基本实施条件	备注
场地	每个商务英语实训室配置 40 个操作台面和座位，每个实训室照明通风良好。	必备
设备	每个商务英语实训室配有 1 台服务器、40—50 台计算机，并安装 Office 办公软件，配置局域网。	必备

测评专家	每 40 名考生配备 1 名考评员。考评员要求具备至少二年以上从事国际贸易工作经验或二年以上外贸单证缮制实践教学指导经历。	必备
------	---	----

(3) 考核时量

考核时间：90 分钟

(4) 评分标准

模块总分	评价内容	配分		考核点	备注
岗位核心技能模块项目二：外贸单证缮制 (总分 100 分，占总评分的 50%)	职业素养与操作规范 (10 分)	职业素养 (6 分)	2 分	(1) 具备外贸从业人员基本素质，认真严谨、耐心细致、恪守信誉、实事求是、服从安排，听从指挥、举止文明；	在考试过程中不服从安排、举止不得当者，记 0 分。
			2 分	具备对外贸合同及信用证信息甄别正误及修正能力、正确缮制单证能力，做到数据计算准确、信息填写正确、单据填写完整；	与所述能力及素养不符，扣 1-2 分。
			2 分	(3) 具备正确规范操作外贸电商平台能力，具有对外贸产品筛选关键信息的能力，符合外贸行业对外贸电商运营等相关岗位需求。	与所述能力及素养不符，扣 1-2 分。
		操作规范 (4 分)	2 分	(1) 具备使用办公设备和 Office 办公软件的能力，在考核过程中以及考核结束后，不私自更换电脑、不随意关闭或重启电脑，没征求监考老师同意不随意提前或推迟交卷；	若私自更换电脑、随意关闭或重启电脑，记 0 分。
			2 分	(2) 能严格遵守企业 6S 管理要求（整理、整顿、清扫、清洁、素养、安全）。	若未遵守企业 6S 管理要求，记 0 分。
			2 分	(3) 货物包装、体积是否有误；	合同审核共 12 个考核点，有 8 处错误，每处 2 分，找出错误计 1
	作品 (90 分)	合同审核 (16 分)	2 分	(1) 买卖双方的名称与地址是否有误；	合同审核共 12 个考核点，有 8 处错误，每处 2 分，找出错误计 1
			2 分	(2) 品名、规格、数量、重量、单价是否有误；	
			2 分	(3) 货物包装、体积是否有误；	

			2分	(4) 使用的贸易术语是否有误;	分, 修正错误计1分。
			2分	(5) 合同金额和币种是否有误;	
			2分	(6) 合同中溢短装条款是否有误;	
			2分	(7) 唛头是否有误;	
			2分	(8) 起运港和目的港是否有误;	
			2分	(9) 分批装运和转运是否有误;	
			2分	(10) 保险险别、保险金额是否有误;	
			2分	(11) 最迟装运期是否有误;	
			2分	(12) 汇票的付款期限是否有误。	
		装箱单缮制 (34分)	2分	(1) 进口商名称和地址: 拼写准确无误;	装箱单缮制部分共17个考核点, 每处计2分, 未填、错填每处扣2分。拼写错误每3处扣1分。
			2分	(2) 商业发票号码: 填写准确无误;	
			2分	(3) 商业发票开立日期: 填写准确无误;	
			2分	(4) 合同号码: 填写准确无误;	
			2分	(5) 装运港: 填写准确无误;	
			2分	(6) 目的港: 填写准确无误;	
			2分	(7) 唛头: 描述准确无误;	
			2分	(8) 货物描述及包装: 品名及规格信息填写准确无误, 计量数与外包装数关系表述准确无误;	
			2分	(9) 货物各自外包装总数量: 计算准确无误;	
			2分	(10) 货物各自总体积: 计算准确无误;	
			2分	(11) 货物各自总净重: 计算准确无误;	
			2分	(12) 货物各自总毛重: 计算准确无误;	
			2分	(13) 货物外包装总数量: 计算准确无误;	
			2分	(14) 货物总体积: 计算准确无误;	

			2分	(15) 货物总净重: 计算准确无误;	
			2分	(16) 货物总毛重: 计算准确无误;	
			2分	(17) 货物外包装总数量大写: 英文拼写正确。	
		保险单缮制 (30分)	2分	(1) 发票号码: 填写准确无误;	保险单缮制部分共15个考核点, 每处计2分, 未填、错填每处扣2分。拼写错误每3处扣1分。
			2分	(2) 保险单号次: 填写准确无误;	
			2分	(3) 被保险人公司名称和地址: 填写准确无误;	
			2分	(4) 被保险货物名称: 填写准确无误;	
			2分	(5) 外包装的数量和单位: 填写准确无误;	
			2分	(6) 保险金额阿拉伯数字小写: 计算准确无误, 填写正确;	
			2分	(7) 承保险别条款: 填写准确无误, 拼写正确;	
			2分	(8) 货物唛头: 填写准确无误;	
			2分	(9) 保险金额英文大写: 计算准确无误, 拼写正确;	
			2分	(10) 船名和航次: 填写准确无误;	
			2分	(11) 开航日期即提单日期: 填写准确无误;	
			2分	(12) 装运港: 填写准确无误;	
			2分	(13) 目的港: 填写准确无误;	
			2分	(14) 赔款偿付地点及币种: 填写准确无误;	
			2分	(15) 投保日期及地点: 填写准确无误。	
		产地证缮制 (10分)	1分	(1) 原产地证书编号: 填写准确无误;	产地证缮制部分共10个考核点, 每处计
			1分	(2) 发货方: 名称、详细地址及国家(地	

				区)，拼写准确无误；	1分，未填、错填每处扣1分。拼写错误每3处扣1分。
		1分	(3) 收货方：最终收货方的名称、详细地址及国家（地区），拼写准确无误；		
		1分	(4) 运输方式及路线：起运港、目的港及运输方式，填写准确无误；		
		1分	(5) 目的地国家（地区）：货物抵达的最终进口国（地区），填写准确无误；		
		1分	(6) 唛头：填写准确无误；		
		1分	(7) 包装数量及种类、货物描述：拼写正确，并在末行加上截止线；		
		1分	(8) 海关代码（一般原产地证）、原产地标准（普惠制产地证 Form A）：填写准确无误；		
		1分	(9) 所有商品总毛重或者其他数量：数量计算准确。		
		1分	(10) 发票的号码和开立日期：填写准确无误。		

13. 试题编号：2-2-13 信用证审核、单证缮制

(1) 任务描述

任务 1：信用证审核：

熟悉 UCP600 相关条款；读懂外贸合同条款；读懂并审核 L/C 各条款；修改 L/C 中的问题条款。

注意：考试资料中的信用证为错误的信用证，考试中涉及到信用证的信息必须参考修改正确的信用证的信息，否则造成的制单错误将不计分。

任务 2：装箱单缮制

分析信用证中涉及装箱单缮制的相关条款；准确缮制装箱单；确保缮制的装箱单与信用证的条款一致。

任务 3：保险单缮制

分析信用证的保险条款；准确缮制保险单；确保缮制的保险单与信用证的条款一致。

任务 4：产地证缮制

分析信用证中涉及产地证缮制的相关条款；准确缮制产地证；确保缮制的产地证与信用证的条款一致。

背景资料

1、出口方基本情况

Company	BROAD AIR QUALITY TECHNOLOGY GROUP
Url	http://www.broad.com:8089/english/
Office Address	YUANDA TOWN, YUANDA 3RD ROAD, CHANGSHA, HUNAN, CHINA
Zip code	410138
Phone	86-731-84086688
Fax	86-731-84610087
E-mail	international@broad.net

2、进口方基本情况

Company	GALAXY REFRIGERATION PRIVATE LIMITED CO.
Url	http://www.galaxyintl.com/
Office Address	NO. D-8, SHANTI KUNJ, NEAR CHURCH, VASANT KUNJ, NEW DELHI, INDIA
Tollfree	+(91)-9810008066
Phone	+(91)-(11)-26130435/ 26130436
Fax	+(91)-(11)-26130436

3、合同

销售合同

SALES CONTRACT

SELLER: BROAD AIR QUALITY TECHNOLOGY GROUP NO.: BRA10478-23
 YUANDA TOWN, YUANDA 3RD ROAD, DATE: AUG. 17, 2022
 CHANGSHA, HUNAN, CHINA SIGNED IN: CHANGSHA

BUYER: GALAXY REFRIGERATION PRIVATE LIMITED CO.
 NO. D-8, SHANTI KUNJ, NEAR CHURCH, VASANT KUNJ, NEW DELHI, INDIA

This contract is made by and agreed between the BUYER and SELLER, in accordance with the terms and conditions stipulated below.

1. Commodity & Specification	2. Quantity	3. Unit Price & Trade Terms	4. Amount
CIF NEW DELHI			
BROAD FRESH AIR MACHINE			
TB100	1,000 UNITS	USD 210/UNIT	USD 210,000.00
DC3.6	200 UNITS	USD 530/UNIT	USD 106,000.00
DC5.4	300 UNITS	USD 680/UNIT	USD 204,000.00
Total:	1,500 UNITS		USD 520,000.00
5. Total Value	SAY U.S. DOLLARS FIVE HUNDRED AND TWENTY THOUSAND ONLY.		
6. Packing	EACH PRODUCT SHALL BE PACKED IN A PLASTIC BAG AND EACH BAG IN AN OVERLAP SLOTTED WATERPROOF CARTON.		
7. Shipping Marks	GALAXY BRA10478-23 NO. 1-1500		
8. Time of Shipment & means of Transportation	TO BE EFFECTED BEFORE THE END OF SEPTEMBER 2022 FROM SHANGHAI TO NEW DELHI WITH PARTIAL SHIPMENT AND TRANSSHIPMENT NOT ALLOWED.		
9. Port of Loading & Destination	FROM: SHANGHAI TO: NEW DELHI		
10. Insurance	THE SELLER SHALL COVER INSURANCE AGAINST ALL RISKS FOR 110% OF THE TOTAL INVOICE VALUE AS PER THE RELEVANT OCEAN MARINE CARGO OF P.I.C.C. DATED 1/1/1981		
11. Terms of Payment	TO BE MADE BY SIGHT L/C		
12. Remarks			

The Buyer
 GALAXY
 REFRIGERATION

The Seller
 BROAD AIR QUALITY
 TECHNOLOGY GROUP

PRIVATE LIMITED CO.

(signature)

(signature)

4、信用证

27: SEQUENCE OF TOTAL 1/1

40A: FORM OF DOCUMENTARY CREDIT REVOCABLE

20: DOCUMENTARY CREDIT NUMBER SBOI 10933-2798

31C: DATE OF ISSUE 220830

31D: DATE AND PLACE OF EXPIRY 220821 CHINA

50: APPLICANT
GALAXY REFRIGERATION PRIVATE LIMITED GROUP.
NO. D-8, SHANTI KUNJ, NEAR CHURCH, VASANT KUNJ, NEW DELHI, INDIA

59: BENEFICIARY
BROAD AIR QUALITY TECHNOLOGY GROUP
YUANDA TOWN, YUANDA 3RD ROAD, CHANGSHA, HUNAN, CHINA

32B: AMOUNT USD 52,000.00

39B: CREDIT AMT NOT EXCEEDING

41D: AVAILABLE WITH BY ANY BANK IN CHINA

42C: DRAFTS AT 30 DAYS AFTER AT SIGHT

42D: DRAWEE STATEBANK OF INDIA NEW DEIHI
BRANCH

43P: PARTIAL SHIPMENTS ALLOWED

43T: TRANSSHIPMENT NOT ALLOWED

44A: LOADING ON BOARD SHANGHAI, CHINA

44B: FOR TRANSPORTATION TO NEW YORK, INDIA

44C: LATEST DATE OF SHIPMENT 220930

45A: DESCRIPTION OF GOODS
BROAD FRESH AIR MACHINE
1000 UNITS TB100 USD 210/UNIT
200 UNITS DC3.6 USD 530/UNIT
300 UNITS DC5.4 USD 680/UNIT
CIF NEW DELHI

46A: DOCUMENTS REQUIRED
+SIGNED COMMERCIAL INVOICE IN TRIPLICATE.

+PACKING LIST IN TRIPLICATE.

+CERTIFICATE OF ORIGIN GSP CHINA FORM A, ISSUED BY THE CHAMBER OF COMMERCE OR OTHER AUTHORITY DULY ENTITLED FOR THIS PURPOSE.

+FULL SET OF CLEAN ON BOARD OCEAN BILLS OF LADING, MADE OUT TO ORDER OF SHIPPER AND BLANK ENDORSED AND MARKED "FREIGHT PREPAID" AND NOTIFY APPLICANT.

+FULL SET OF NEGOTIABLE INSURANCE POLICY OR CERTIFICATE BLANK ENDORSED FOR 110 PCT OF INVOICE VALUE COVERING ALL RISKS AND WAR RISK.

+SHIPPING ADVICES MUST BE SENT TO APPLICANT ON THE DATE OF SHIPMENT ADVISING SHIPPING MARKS, COMMODITY NAME, CARTON NUMBERS, TOTAL GROSS WEIGHT, VESSEL NAME, BILL OF LADING NO., PORT OF LOADING, DESTINATION, CONTRACT NO., INVOICE NO., LETTER OF CREDIT NO.

+COPY OF LETTER FROM BENEFICIARY TO OUR APPLICANT EVIDENCING A NON NEGOTIABLE BILL OF LADING TOGETHER WITH COPY OF OTHER DOCUMENTS WAS SENT DIRECTLY TO THEM AFTER ONE DAY FROM SHIPMENT DATE.

71B: CHARGES ALL BANKING CHARGES OUTSIDE INDIA ARE FOR ACCOUNT OF BENEFICIARY.

48: PERIOD FOR DOCUMENTS MUST BE PRESENTED WITHIN 15 DAYS PRESENTATION AFTER THE DATE OF SHIPMENT BUT WITHIN THE VALIDITY OF THE CREDIT.

5、相关资料

(1) INVOICE NO.: BR10897-334

(2) INVOICE DATE: AUG. 27, 2022

(3) PACKING

G. W.(KGS/CARTON)	N. W.(KGS/CARTON)	MEAS (CBM/CARTON)
35	32	0.432

PACKED IN 1500 CARTONS, ONE UNIT PER CARTON
TOTAL TWELVE 40' CONTAINERS

(4) VESSEL: SEAF098

(5) B/L NO.: COS340212

(6) B/L DATE: SEPT. 20, 2022

(7) POLICY NO.: PICC09387

(8) REFERENCE NO.: 20220916

抽考试题

1、请根据考试资料中的合同 3 审核错误的信用证 4，指出不符之处并修正。

(本题共 16 分)

1. _____
2. _____
3. _____
4. _____
5. _____
6. _____
7. _____
8. _____

2、请根据以上资料缮制装箱单。(本题共 34 分)

(注：信用证的信息必须是修正后的正确信息)

远大集团

Broad Air Quality Technology Group

Yunda Town, Yuanda 3rd Road, Changsha, Hunan, China

TEL: 86-731-84086688 FAX: 86-731-84610087

装箱单

PACKING LIST

TO:

INVOICE NO.:

DATE:

S/C NO.:

FROM:

TO:

MARKS & NO.	DESCRIPTION S & PACKING	QTY	MEAS (M³)	N.W. (KGS)	G.W. (KGS)
----------------------------	--	------------	---------------------------------	-----------------------	-----------------------

Total:					

SAY TOTAL :

BROAD AIR QUALITY TECHNOLOGY GROUP

远大集团

陈洁

(Authorized Signature)

- 3、请根据以上资料缮制保险单。（本题共 30 分）
（注：信用证的信息必须是修正后的正确信息）

中保财产保险有限公司

The People's Insurance (Property) Company of China Ltd.

发票号码

保险单号次

Invoice No.

Policy No.

海洋货物运输保险单

MARINE CARGO TRANSPORTATION INSURANCE POLICY

被保险人

Insured:

中保财产保险有限公司（以下简称本公司）根据被保险人的要求，及其所缴付约定的保险费，按照本保险单承担的险别和背面所载条款与下列特别条款承保下列货物运输保险，特签发本保单。

This policy of Insurance witnesses that The People's Insurance (Property) Company of China, Ltd. (hereinafter called "The company"), at the request of the Insured and consideration of the premium paid to The Company, undertakes to insure the under-mentioned goods in transportation subject to the condition of this Policy as per the Clauses printed overleaf and other special clauses attached hereon.

保险货物项目 Description of Goods	包装、单位、数量 Packaging Unit Quantity	保险金额 Amount Insured
--------------------------------	-------------------------------------	------------------------

--	--	--

承保险别

货物标记

Condition

Marks of Goods

总保险金额:

Total Amount Insured

保费

运输工具

开航日期:

Premium As arranged **Per conveyance S.S**

Slg. On or abt

启运港

目的港

From

To

所保货物，如发生本保险合同单项下可能引起索赔的损失或损坏，应立即通知本公司下述代理人查勘，如有索赔，应向本公司提交保险单正本（本保险单共有 份正本）及有关文件。如一份正本已用于索赔，其余正本则自动失效。

In the event of loss or damage which may result in a claim under this Policy, immediate notice must be given to the Company's Agent as mentioned hereunder. Claims, if any, one of the Original Policy which has been issued in Original(s) together with the relevant documents shall be surrendered to the Company, if one of the Original Policy has been accomplished, the others to be void.

中保财产保险有限公司

The People's Insurance (Property) Company of China Ltd.

赔款偿付地点

Claim payable at

日期

Date

General Manager: 丁宁

地址:

Address:

4、请根据以上资料缮制产地证。（本题共 10 分）

（注：信用证的信息必须是修正后的正确信息）

GENERALIZED SYSTEM OF PREFERENCES

CERTIFICATE OF ORIGIN (FORM A)

1. Goods consigned from: (Exporter's business name, address, country)			Reference No. Issued in _____(Country)		
2. Goods consigned to: (Consignee's name, address, country)			3. For official use		
4. Means of transport and route:					
5. Country/ region of destination:	6. Marks and numbers of Packages:	7. Number and kind of packages; description of goods:	8. Origin criterion (see notes overleaf)	9. Gross weight or other quantity:	10. Number and date of invoices:
11. Declaration by the exporter : The undersigned hereby declares that the above details and statements are correct: that all the goods were produced in <div style="text-align: right;">(Country)</div>			12. Certificate It is hereby certified on the basis of control carried out, that the declaration by the exporter is correct. <div style="text-align: center;">  </div>		

<p>and that they comply with the origin requirements specified for these goods in the Asia-Pacific Trade Agreement for goods exported to</p> <p style="text-align: center;">(Importing Country)</p> <p style="text-align: center;">BROAD AIR QUALITY TECHNOLOGY GROUP</p> <p style="text-align: center;">远大集团</p> <p style="text-align: center;">陈洁</p> <p style="text-align: center;">(Authorized Signature)</p> <p>Place and date, signature of authorized Signatory</p>	<p>Place and date, signature and stamp of Certifying Authority</p>
---	--

(2) 实施条件

项目	基本实施条件	备注
场地	每个商务英语实训室配置 40 个操作台面和座位，每个实训室照明通风良好。	必备
设备	每个商务英语实训室配有 1 台服务器、40—50 台计算机，并安装 Office 办公软件，配置局域网。	必备
测评专家	每 40 名考生配备 1 名考评员。考评员要求具备至少二年以上从事国际贸易工作经验或二年以上外贸单证缮制实践教学指导经历。	必备

(3) 考核时量

考核时间 90 分钟。

(4) 评分标准

模块总分	评价内容	配分	考核点	备注	
岗位核心	职业素养	职业素养	2 分	(1) 具备外贸从业人员基本素质，认真严	在考试过程中

技能模块项目二： 外贸单证缮制 (总分 100 分，占总评分的 50%)	与操作规范 (10 分)	(6 分)		谨、耐心细致、恪守信誉、实事求是、服从安排，听从指挥、举止文明；	不服从安排、举止不当者，记 0 分。
			2 分	具备对外贸合同及信用证信息甄别正误及修正能力、正确缮制单证能力，做到数据计算准确、信息填写正确、单据填写完整；	与所述能力及素养不符，扣 1-2 分。
			2 分	(3) 具备正确规范操作外贸电商平台能力，具有对外贸产品筛选关键信息的能力，符合外贸行业对外贸电商运营等相关岗位需求。	与所述能力及素养不符，扣 1-2 分。
		操作规范 (4 分)	2 分	(1) 具备使用办公设备和 Office 办公软件的能力，在考核过程中以及考核结束后，不私自更换电脑、不随意关闭或重启电脑，没征求监考老师同意不随意提前或推迟交卷；	若私自更换电脑、随意关闭或重启电脑，记 0 分。
			2 分	(2) 能严格遵守企业 6S 管理要求（整理、整顿、清扫、清洁、素养、安全）。	若未遵守企业 6S 管理要求，记 0 分。
		作品 (90 分)	信用证审核 (16 分)	2 分	(1) 买卖双方的名称与地址是否有误；
	2 分			(2) 品名、规格、数量、重量、单价是否有误；	
	2 分			(3) 货物包装、体积是否有误；	
	2 分			(4) 使用的贸易术语是否有误；	
	2 分			(5) 合同金额和币种是否有误；	
	2 分			(6) 合同中溢短装条款是否有误；	
	2 分			(7) 唛头是否有误；	
	2 分			(8) 起运港和目的港是否有误；	
	2 分	(9) 分批装运和转运是否有误；			
2 分	(10) 保险险别、保险金额是否有误；				
2 分	(11) 最迟装运期是否有误；				
2 分	(12) 汇票的付款期限是否有误；单据条款				

				是否有误。	
		装箱单 缮制 (34分)	2分	(1) 进口商名称和地址：拼写准确无误；	装箱单缮制部分共17个考核点，每处计2分，未填、错填每处扣2分。拼写错误每3处扣1分。
			2分	(2) 商业发票号码：填写准确无误；	
			2分	(3) 商业发票开立日期：填写准确无误；	
			2分	(4) 合同号码：填写准确无误；	
			2分	(5) 装运港：填写准确无误；	
			2分	(6) 目的港：填写准确无误；	
			2分	(7) 唛头：描述准确无误；	
			2分	(8) 货物描述及包装：品名及规格信息填写准确无误，计量数与外包装数关系表述准确无误；	
			2分	(9) 货物各自外包装总数量：计算准确无误；	
			2分	(10) 货物各自总体积：计算准确无误；	
			2分	(11) 货物各自总净重：计算准确无误；	
			2分	(12) 货物各自总毛重：计算准确无误；	
			2分	(13) 货物外包装总数量：计算准确无误；	
			2分	(14) 货物总体积：计算准确无误；	
			2分	(15) 货物总净重：计算准确无误；	
			2分	(16) 货物总毛重：计算准确无误；	
			2分	(17) 货物外包装总数量大写：英文拼写正确。	
		保险单 缮制 (30分)	2分	(1) 发票号码：填写准确无误；	保险单缮制部分共15个考核点，每处计2分，未填、错填每处扣2分。
			2分	(2) 保险单号次：填写准确无误；	
			2分	(3) 被保险人公司名称和地址：填写准确无误；	

			2分	(4) 被保险货物名称: 填写准确无误;	分。拼写错误每3处扣1分。
			2分	(5) 外包装的数量和单位: 填写准确无误;	
			2分	(6) 保险金额阿拉伯数字小写: 计算准确无误, 填写正确;	
			2分	(7) 承保险别条款: 填写准确无误, 拼写正确;	
			2分	(8) 货物唛头: 填写准确无误;	
			2分	(9) 保险金额英文大写: 计算准确无误, 拼写正确;	
			2分	(10) 船名和航次: 填写准确无误;	
			2分	(11) 开航日期即提单日期: 填写准确无误;	
			2分	(12) 装运港: 填写准确无误;	
			2分	(13) 目的港: 填写准确无误;	
			2分	(14) 赔款偿付地点及币种: 填写准确无误;	
			2分	(15) 投保日期及地点: 填写准确无误。	
		产地证缮制 (10分)	1分	(1) 原产地证书编号: 填写准确无误;	
			1分	(2) 发货方: 名称、详细地址及国家(地区), 拼写准确无误;	
			1分	(3) 收货方: 最终收货方的名称、详细地址及国家(地区), 拼写准确无误;	
			1分	(4) 运输方式及路线: 起运港、目的港及运输方式, 填写准确无误;	
			1分	(5) 目的地国家(地区): 货物抵达的最终进口国(地区), 填写准确无误;	
			1分	(6) 唛头: 填写准确无误;	
			1分	(7) 包装数量及种类、货物描述: 拼写正	

				确，并在末行加上截止线；	
			1分	(8) 海关代码（一般原产地证）、原产地标准（普惠制产地证 Form A）：填写准确无误；	
			1分	(9) 所有商品总毛重或者其他数量：数量计算准确。	
			1分	(10) 发票的号码和开立日期：填写准确无误。	

14. 试题编号：2-2-14 信用证审核、单证缮制

(1) 任务描述

任务 1：信用证审核

熟悉 UCP600 相关条款；读懂外贸合同条款；读懂并审核 L/C 各条款；修改 L/C 中的问题条款。

注意：考试资料中的信用证为错误的信用证，考试中涉及到信用证的信息必须参考修改正确的信用证的信息，否则造成的制单错误将不计分。

任务 2：装箱单缮制

分析信用证中涉及装箱单缮制的相关条款；准确缮制装箱单；确保缮制的装箱单与信用证的条款一致。

任务 3：保险单缮制

分析信用证的保险条款；准确缮制保险单；确保缮制的保险单与信用证的条款一致。

任务 4：产地证缮制

分析信用证中涉及产地证缮制的相关条款；准确缮制产地证；确保缮制的产地证与信用证的条款一致。

背景资料

1、出口方基本情况

Company	HUNAN HAILI CHEMICAL INDUSTRY CO., LTD. (Hunan Haili)
Url	http://www.hnhlc.com
Office Address	NO. 251, 2ND SECTION, FURONG(M) ROAD, CHANGSHA, HUNAN, CHINA
Zip code	410007
Phone	86-731-85357829
Fax	86-731-85357977
E-mail	sh600731@sina.com

2、进口方基本情况

Company	DEVIDAYAL (SALES) LIMITED
Url	http://www.devidayalagro.com/
Office Address	1ST FLOOR DEVIDAYAL ESTATE, REAY ROAD, MUMBAI 400010, INDIA
Tollfree	无
Phone	+91-22-23714913/ 23734871
Fax	+91-22-23742708

3、合同

销售合同

SALES CONTRACT

SELLER: HUNAN HAILI CHEMICAL INDUSTRY CO., LTD.
NO. 251, 2ND SECTION, FURONG(M) ROAD, CHANGSHA, HUNAN, CHINA

NO.: RT05342
DATE: MAR.20,2022
SIGNED IN: CHANGSHA

BUYER: DEVIDAYAL (SALES) LIMITED
1ST FLOOR DEVIDAYAL ESTATE, REAY ROAD, MUMBAI 400010, INDIA

This contract is made by and agreed between the BUYER and SELLER, in accordance with the terms and conditions stipulated below.

1. Commodity & Specification	2. Quantity	3. Unit Price & Trade Terms	4. Amount
CIF MUMBAI			
MONOSULTAP	15 MT	USD 1,600/MT	USD 24,000.00
Total:	15 MT		USD 24,000.00

5. Total Value	SAY U.S. DOLLARS TWENTY FOUR THOUSAND ONLY.
6. Packing	G. W.: 51 KGS/BAG N. W.: 50 KGS/BAG MEAS: 0.2 CBM/BAG PACKED IN 300 BAGS
7. Shipping Marks	N/M
8. Time of Shipment & means of Transportation	TO BE EFFECTED BEFORE THE END OF JUNE 2022 FROM SHANGHAI TO MUMBAI WITH PARTIAL SHIPMENT NOT ALLOWED AND TRANSSHIPMENT ALLOWED.
10. Port of Loading & Destination	FROM: SHANGHAI TO: MUMBAI
10. Insurance	THE SELLER SHALL COVER INSURANCE AGAINST ALL RISKS & WAR RISK FOR 110% OF THE TOTAL INVOICE VALUE AS PER THE RELEVANT OCEAN MARINE CARGO OF P.I.C.C. DATED 1/1/1981
11. Terms of Payment	TO BE MADE BY SIGHT L/C
12. Remarks	

The Buyer	The Seller
DEVIDAYAL(SALES) LIMITED	HUNAN HAILI CHEMICAL INDUSTRY CO., LTD.
(signature)	(signature)

4、信用证

27:	SEQUENCE OF TOTAL	1/1
40A:	FORM OF DOCUMENTARY CREDIT	REVOCABLE
20:	DOCUMENTARY CREDIT NUMBER	80008/04
31C:	DATE OF ISSUE	220412
31D:	DATE AND PLACE OF EXPIRY	220321 INDIA
50:	APPLICANT	

DEVIDAYAL(SALES) LIMITED
1ST FLOOR DEVIDAYAL ESTATE, REAY ROAD, MUNBAI 400011, INDIA

59: BENEFICIARY

HUNAN HAILI CHEMICAL INDUSTRY CO., LTD.
NO. 251, 2ND SECTION, FURONG(M) ROAD CHANGSHA, HUNAN, CHINA

32B: AMOUNT USD 240,000.00

39B: CREDIT AMT NOT EXCEEDING

41D: AVAILABLE WITH BY ANY BANK IN CHINA

42C: DRAFTS AT AT SIGHT

42D: DRAWEE UNION BANK OF INDIA, MUMBAI
BRANCH

43P: PARTIAL SHIPMENTS NOT ALLOWED

43T: TRANSSHIPMENT NOT ALLOWED

44A: LOADING ON BOARD SHANGHAI, CHINA

44B: FOR TRANSPORTATION TO MUMBAI, INDIA

44C: LATEST DATE OF SHIPMENT 220630

45A: DESCRIPTION OF GOODS
15 MT MONOSULTAP
USD1,600/MT CFR MUMBAI

46A: DOCUMENTS REQUIRED

+SIGNED COMMERCIAL INVOICE IN TRIPLICATE.

+PACKING LIST IN TRIPLICATE.

+CERTIFICATE OF ORIGIN GSP CHINA FORM A, ISSUED BY THE CHAMBER OF
COMMERCE OR OTHER AUTHORITY DULY ENTITLED FOR THIS PURPOSE.

+FULL SET OF CLEAN ON BOARD OCEAN BILLS OF LADING, MADE OUT TO
ORDER OF SHIPPER AND BLANK ENDORSED AND MARKED "FREIGHT PREPAID"
AND NOTIFY APPLICANT.

+FULL SET OF NEGOTIABLE INSURANCE POLICY OR CERTIFICATE BLANK
ENDORSED FOR 130 PCT OF INVOICE VALUE COVERING ALL RISKS.

+SHIPPING ADVICES MUST BE SENT TO APPLICANT ON THE DATE OF SHIPMENT
ADVISING SHIPPING MARKS, COMMODITY NAME, CARTON NUMBERS, TOTAL
GROSS WEIGHT, VESSEL NAME, BILL OF LADING NO., PORT OF LOADING,
DESTINATION, CONTRACT NO., INVOICE NO., LETTER OF CREDIT NO.

+COPY OF LETTER FROM BENEFICIARY TO OUR APPLICANT EVIDENCING A NON
NEGOTIABLE BILL OF LADING TOGETHER WITH COPY OF OTHER DOCUMENTS
WAS SENT DIRECTLY TO THEM AFTER ONE DAY FROM SHIPMENT DATE.

71B: CHARGES ALL BANKING CHARGES OUTSIDE INDIA ARE FOR ACCOUNT OF BENEFICIARY.

48: PERIOD FOR PRESENTATION DOCUMENTS MUST BE PRESENTED WITHIN 15 DAYS AFTER THE DATE OF SHIPMENT BUT WITHIN THE VALIDITY OF THE CREDIT.

5、相关资料

(1) INVOICE NO.: XH56671

(2) INVOICE DATE: APRIL 25, 2022

(3) PACKING

G. W.: 51 KGS/BAG

N. W.: 50 KGS/BAG

MEAS: 0.2 CBM/BAG

PACKED IN 300 BAGS

TOTAL TWO 20' CONTAINERS

(4) VESSEL: NANGXING V. 086

(5) B/L NO.: COCS0511861

(6) B/L DATE: MAY 10, 2022

(7) POLICY NO.: SH150527

(8) REFERENCE NO.: 20220528

抽考试题

1、请根据考试资料中的合同 3 审核错误的信用证 4，指出不符之处并修正。

(本题共 16 分)

1. _____

2. _____

3. _____

4. _____

5. _____

6. _____

7. _____

The People's Insurance (Property) Company of China Ltd.

发票号码

保险单号次

Invoice No.

Policy No.

海 洋 货 物 运 输 保 险 单

MARINE CARGO TRANSPORTATION INSURANCE POLICY

被保险人

Insured:

中保财产保险有限公司(以下简称本公司)根据被保险人的要求,及其所缴付约定的保险费,按照本保险单承担的险别和背面所载条款与下列特别条款承保下列货物运输保险,特签发本保单。

This policy of Insurance witnesses that The People's Insurance (Property) Company of China, Ltd. (hereinafter called "The company"), at the request of the Insured and consideration of the premium paid to The Company, undertakes to insure the under-mentioned goods in transportation subject to the condition of this Policy as per the Clauses printed overleaf and other special clauses attached hereon.

保险货物项目 Description of Goods	包装、单位、数量 Parking Unit Quantity	保险金额 Amount Insured

承保险别

货物标记

Condition

Marks of Goods

总保险金额:

Total Amount Insured

保费

运输工具

开航日期:

Premium As arranged

Per conveyance S.S

Slg. On or abt

启运港

目的港

From

To

所保货物，如发生本保险合同单项下可能引起索赔的损失或损坏，应立即通知本公司下述代理人查勘，如有索赔，应向本公司提交保险单正本（本保险单共有 份正本）及有关文件。如一份正本已用于索赔，其余正本则自动失效。

In the event of loss or damage which may result in a claim under this Policy, immediate notice must be given to the Company's Agent as mentioned hereunder. Claims, if any, one of the Original Policy which has been issued in Original(s) together with the relevant documents shall be surrendered to the Company, if one of the Original Policy has been accomplished, the others to be void.

中保财产保险有限公司

The People's Insurance (Property) Company of China Ltd.

赔款偿付地点

Claim payable at

日期

Date

General Manager:

丁宁

地址：

Address:

4、请根据以上资料缮制产地证。（本题共 10 分）

（注：信用证的信息必须是修正后的正确信息）

GENERALIZED SYSTEM OF PREFERENCES

CERTIFICATE OF ORIGIN (FORM A)

1. Goods consigned from: (Exporter's business name, address, country)	Reference No. Issued in _____(Country)
2. Goods consigned to: (Consignee's name, address, country)	3. For official use
4. Means of transport and route:	

6. Country/ region of destination:	6. Marks and numbers of Packages:	7. Number and kind of packages; description of goods:	8. Origin criterion (see notes overleaf)	9. Gross weight or other quantity:	10. Number and date of invoices:
<p>11. Declaration by the exporter :</p> <p>The undersigned hereby declares that the above details and statements are correct: that all the goods were produced in</p> <p style="text-align: center;">(Country)</p> <p>and that they comply with the origin requirements specified for these goods in the Asia-Pacific Trade Agreement for goods exported to</p> <p style="text-align: center;">(Importing Country)</p> <p style="text-align: center;">HUNAN HAILI CHEMICAL INDUSTRY CO., LTD.</p> <p style="text-align: center;">湖南海利化工有限公司</p> <p style="text-align: center;">I 李灿明</p> <p style="text-align: center;">.....</p> <p style="text-align: center;">(Authorized Signature)</p> <p>Place and date, signature of authorized Signatory</p>			<p>12. Certificate</p> <p>It is hereby certified on the basis of control carried out, that the declaration by the exporter is correct.</p> <div style="text-align: center;">  </div> <p>Place and date, signature and stamp of Certifying Authority</p>		

(2) 实施条件

项目	基本实施条件	备注
场地	每个商务英语实训室配置 40 个操作台面和座位，每个实训室照明通风良好。	必备
设备	每个商务英语实训室配有 1 台服务器、40—50 台计算机，并安装 Office 办公软件，配置局域网。	必备
测评专家	每 40 名考生配备 1 名考评员。考评员要求具备至少二年以上从事国际贸易工作经验或二年以上外贸单证缮制实践教学指导经历。	必备

(3) 考核时量

考核时间 90 分钟。

(4) 评分标准

模块总分	评价内容	配分	考核点	备注	
岗位核心技能模块项目二：外贸单证缮制（总分 100 分，占总评分的 50%）	职业素养与操作规范（10 分）	职业素养（6 分）	2 分	（1）具备外贸从业人员基本素质，认真严谨、耐心细致、恪守信誉、实事求是、服从安排，听从指挥、举止文明；	在考试过程中不服从安排、举止不得当者，记 0 分。
			2 分	具备对外贸合同及信用证信息甄别正误及修正能力、正确缮制单证能力，做到数据计算准确、信息填写正确、单据填写完整；	与所述能力及素养不符，扣 1-2 分。
			2 分	（3）具备正确规范操作外贸电商平台能力，具有对外贸产品筛选关键信息的能力，符合外贸行业对外贸电商运营等相关岗位需求。	与所述能力及素养不符，扣 1-2 分。
		操作规范（4 分）	2 分	（1）具备使用办公设备和 Office 办公软件的能力，在考核过程中以及考核结束后，不私自更换电脑、不随意关闭或重启电脑，没征求监考老师同意不随意提前或推迟交卷；	若私自更换电脑、随意关闭或重启电脑，记 0 分。
			2 分	（2）能严格遵守企业 6S 管理要求（整理、	若未遵守企业

				整顿、清扫、清洁、素养、安全)。	6S 管理要求，记 0 分。
作品 (90 分)	信用证 审核 (16 分)	2 分	(1) 买卖双方的名称与地址是否有误；	信用证审核共 12 个考核点，有 8 处错误，每处 2 分，找出错误计 1 分，修正错误计 1 分。	
		2 分	(2) 品名、规格、数量、重量、单价是否有误；		
		2 分	(3) 货物包装、体积是否有误；		
		2 分	(4) 使用的贸易术语是否有误；		
		2 分	(5) 合同金额和币种是否有误；		
		2 分	(6) 合同中溢短装条款是否有误；		
		2 分	(7) 唛头是否有误；		
		2 分	(8) 起运港和目的港是否有误；		
		2 分	(9) 分批装运和转运是否有误；		
		2 分	(10) 保险险别、保险金额是否有误；		
		2 分	(11) 最迟装运期是否有误；		
		2 分	(12) 汇票的付款期限是否有误；单据条款是否有误。		
	装箱单 缮制 (34 分)	2 分	(1) 进口商名称和地址：拼写准确无误；	装箱单缮制部分共 17 个考核点，每处计 2 分，未填、错填每处扣 2 分。拼写错误每 3 处扣 1 分。	
		2 分	(2) 商业发票号码：填写准确无误；		
		2 分	(3) 商业发票开立日期：填写准确无误；		
		2 分	(4) 合同号码：填写准确无误；		
		2 分	(5) 装运港：填写准确无误；		
		2 分	(6) 目的港：填写准确无误；		
		2 分	(7) 唛头：描述准确无误；		
2 分	(8) 货物描述及包装：品名及规格信息填写准确无误，计量数与外包装数关系表述准确无误；				
2 分	(9) 货物各自外包装总数量：计算准确无				

				误；	
			2分	(10) 货物各自总体积：计算准确无误；	
			2分	(11) 货物各自总净重：计算准确无误；	
			2分	(12) 货物各自总毛重：计算准确无误；	
			2分	(13) 货物外包装总数量：计算准确无误；	
			2分	(14) 货物总体积：计算准确无误；	
			2分	(15) 货物总净重：计算准确无误；	
			2分	(16) 货物总毛重：计算准确无误；	
			2分	(17) 货物外包装总数量大写：英文拼写正确。	
		保险单缮制 (30分)	2分	(1) 发票号码：填写准确无误；	保险单缮制部分共15个考核点，每处计2分，未填、错填每处扣2分。拼写错误每3处扣1分。
			2分	(2) 保险单号次：填写准确无误；	
			2分	(3) 被保险人公司名称和地址：填写准确无误；	
			2分	(4) 被保险货物名称：填写准确无误；	
			2分	(5) 外包装的数量和单位：填写准确无误；	
			2分	(6) 保险金额阿拉伯数字小写：计算准确无误，填写正确；	
			2分	(7) 承保险别条款：填写准确无误，拼写正确；	
			2分	(8) 货物唛头：填写准确无误；	
			2分	(9) 保险金额英文大写：计算准确无误，拼写正确；	
			2分	(10) 船名和航次：填写准确无误；	
			2分	(11) 开航日期即提单日期：填写准确无误；	

			2分	(12) 装运港: 填写准确无误;	
			2分	(13) 目的港: 填写准确无误;	
			2分	(14) 赔款偿付地点及币种: 填写准确无误;	
			2分	(15) 投保日期及地点: 填写准确无误.	
		产地证缮制 (10分)	1分	(1) 原产地证书编号: 填写准确无误;	产地证缮制部分共10个考核点, 每处计1分, 未填、错填每处扣1分。拼写错误每3处扣1分。
			1分	(2) 发货方: 名称、详细地址及国家(地区), 拼写准确无误;	
			1分	(3) 收货方: 最终收货方的名称、详细地址及国家(地区), 拼写准确无误;	
			1分	(4) 运输方式及路线: 起运港、目的港及运输方式, 填写准确无误;	
			1分	(5) 目的地国家(地区): 货物抵达的最终进口国(地区), 填写准确无误;	
			1分	(6) 唛头: 填写准确无误;	
			1分	(7) 包装数量及种类、货物描述: 拼写正确, 并在末行加上截止线;	
			1分	(8) 海关代码(一般原产地证)、原产地标准(普惠制产地证 Form A): 填写准确无误;	
			1分	(9) 所有商品总毛重或者其他数量: 数量计算准确。	
			1分	(10) 发票的号码和开立日期: 填写准确无误。	

15. 试题编号: 2-2-15 信用证审核、单证缮制

(1) 任务描述

任务 1：信用证审核：

熟悉 UCP600 相关条款；读懂外贸合同条款；读懂并审核 L/C 各条款；修改 L/C 中的问题条款。

注意：考试资料中的信用证为错误的信用证，考试中涉及到信用证的信息必须参考修改正确的信用证的信息，否则造成的制单错误将不计分。

任务 2：装箱单缮制

分析信用证中涉及装箱单缮制的相关条款；准确缮制装箱单；确保缮制的装箱单与信用证的条款一致。

任务 3：保险单缮制

分析信用证的保险条款；准确缮制保险单；确保缮制的保险单与信用证的条款一致。

任务 4：产地证缮制

分析信用证中涉及产地证缮制的相关条款；准确缮制产地证；确保缮制的产地证与信用证的条款一致。

背景资料

1、出口方基本情况

Company	HUNAN HAILI CHEMICAL INDUSTRY CO., LTD. (Hunan Haili)
Url	http://www.hnhlc.com
Office Address	NO. 251, 2ND SECTION, FURONG(M) ROAD, CHANGSHA, HUNAN, CHINA
Zip code	410007
Phone	86-731-85357829
Fax	86-731-85357977

E-mail	sh600731@sina.com
--------	-------------------

2、进口方基本情况

Company	MAINPLUS CHEMICALS LTD.
Url	http://www.mainpluschem.com/
Office Address	145-157 ST.JOHN STREET, LONDON EC1V 4PY, U.K.
Tollfree	无
Phone	+44 20 8816 7120
Fax	+44 70 0602 6085

3、合同

销售合同

SALES CONTRACT

SELLER: HUNAN HAILI CHEMICAL INDUSTRY CO., LTD.
NO. 251, 2ND SECTION, FURONG (M) ROAD, CHANGSHA, HUNAN, CHINA
BUYER: MAINPLUS CHEMICALS LTD.
145-157 ST. JOHN STREET, LONDON EC1V 4PY, U.K.

NO.: RT06231
DATE: JAN. 22, 2022
SIGNED IN: CHANGSHA

This contract is made by and agreed between the BUYER and SELLER, in accordance with the terms and conditions stipulated below.

1. Commodity & Specification	2. Quantity	3. Unit Price & Trade Terms	4. Amount
CIF LONDON			
CARBENDZIM			
50%WP	4.5 MT	USD 3800/MT	USD 17,100.00
25%WP	5.0 MT	USD 3600/MT	USD 18,000.00
Total:	9.5 MT		USD 35,100.00

5. Total Value SAY U.S. DOLLARS THIRTY FIVE THOUSAND ONE HUNDRED ONLY.

6. Packing G. W.: 26 KGS/ WOVEN BAG
N. W.: 25 KGS/ WOVEN BAG
MEAS: 0.03 CBM/ WOVEN BAG

7. Shipping Marks M.P.C.L.
LONDON
C/NO. 1-380

8. Time of Shipment & means of Transportation TO BE EFFECTED BEFORE THE END OF MAY 2022 FROM SHANGHAI TO LONDON WITH PARTIAL SHIPMENT AND TRANSSHIPMENT NOT ALLOWED

11. Port of Loading & Destination FROM: SHANGHAI
TO: LONDON

10. Insurance THE SELLER SHALL COVER INSURANCE AGAINST ALL RISKS & WAR RISK FOR 110% OF THE TOTAL INVOICE VALUE AS PER THE RELEVANT OCEAN MARINE CARGO OF P.I.C.C. DATED 1/1/1981

11. Terms of Payment TO BE MADE BY SIGHT L/C

12. Remarks

The Buyer	The Seller
MAINPLUS CHEMICALS LTD.	HUNAN HAILI CHEMICAL INDUSTRY CO., LTD.
(signature)	(signature)

4、信用证

27:	SEQUENCE OF TOTAL	1/1
40A:	FORM OF DOCUMENTARY CREDIT	REVOCABLE
20:	DOCUMENTARY CREDIT NUMBER	31176
31C:	DATE OF ISSUE	220321
31D:	DATE AND PLACE OF EXPIRY	220621 CHINA
50:	APPLICANT	
	MAINPLU CHEMICALS LTD. 145-157 ST.JOHN STREET, LONDON EC1V 4PY, UNITED KINGDOM	
59:	BENEFICIARY	
	HUNAN HAILI CHEMICAL INDUSTRY CO., LTD. NO. 251, 2ND SECTION, FURONG(M) ROAD, CHANGSHA, HUNAN, CHINA	
32B:	AMOUNT	USD 135,100.00
39B:	CREDIT AMT	NOT EXCEEDING
41D:	AVAILABLE WITH BY	ANY BANK IN CHINA
42C:	DRAFTS AT	30 DAYS AFTER SIGHT
42D:	DRAWEE	BARCLYAS BANK
43P:	PARTIAL SHIPMENTS	NOT ALLOWED
43T:	TRANSSHIPMENT	ALLOWED
44A:	LOADING ON BOARD	SHANGHAI, CHINA
44B:	FOR TRANSPORTATION TO	LONDON, U.K.

44C: LATEST DATE OF SHIPMENT 220430

45A: DESCRIPTION OF GOODS
 CARBENDZIM
 4.5 MT 50%WP USD 3800/MT
 5.0 MT 25%WP USD 360/MT
 CIF LONDON

46A: DOCUMENTS REQUIRED

+SIGNED COMMERCIAL INVOICE IN TRIPLICATE.

+PACKING LIST IN TRIPLICATE.

+CERTIFICATE OF ORIGIN GSP CHINA FORM A, ISSUED BY THE CHAMBER OF COMMERCE OR OTHER AUTHORITY DULY ENTITLED FOR THIS PURPOSE.

+FULL SET OF CLEAN ON BOARD OCEAN BILLS OF LADING, MADE OUT TO ORDER OF SHIPPER AND BLANK ENDORSED AND MARKED "FREIGHT PREPAID" AND NOTIFY APPLICANT.

+FULL SET OF NEGOTIABLE INSURANCE POLICY OR CERTIFICATE BLANK ENDORSED FOR 110 PCT OF INVOICE VALUE COVERING ALL RISKS.

+SHIPPING ADVICES MUST BE SENT TO APPLICANT ON THE DATE OF SHIPMENT ADVISING SHIPPING MARKS, COMMODITY NAME, CARTON NUMBERS, TOTAL GROSS WEIGHT, VESSEL NAME, BILL OF LADING NO., PORT OF LOADING, DESTINATION, CONTRACT NO., INVOICE NO., LETTER OF CREDIT NO.

+COPY OF LETTER FROM BENEFICIARY TO OUR APPLICANT EVIDENCING A NON NEGOTIABLE BILL OF LADING TOGETHER WITH COPY OF OTHER DOCUMENTS WAS SENT DIRECTLY TO THEM AFTER ONE DAYS FROM SHIPMENT DATE.

71B: CHARGES ALL BANKING CHARGES OUTSIDE U.K. ARE FOR ACCOUNT OF BENEFICIARY.

48: PERIOD FOR DOCUMENTS MUST BE PRESENTED WITHIN 15 DAYS PRESENTATION AFTER THE DATE OF SHIPMENT BUT WITHIN THE VALIDITY OF THE CREDIT.

5、相关资料

(1) INVOICE NO.: XH64542

(2) INVOICE DATE: JAN. 30, 2022

(3) PACKING

G. W.: 26 KGS/WOVEN BAG

N. W.: 25 KGS/ WOVEN BAG

MEAS: 0.03 CBM/WOVEN BAG

PACKED IN 380 WOVEN BAG
TOTAL ONE 20' CONTAINER

(4) VESSEL: MAY FLOWER V. 092

(5) B/L NO.: COCS1127852

(6) B/L DATE: MAY 25, 2022

(7) POLICY NO.: SH058950

(8) REFERENCE NO.: 20220512

抽考试题

1、请根据考试资料中的合同 3 审核错误的信用证 4，指出不符之处并修正。

(本题共 16 分)

1. _____
2. _____
3. _____
4. _____
5. _____
6. _____
7. _____
8. _____

2、请根据以上资料缮制装箱单。(本题共 34 分)

(注：信用证的信息必须是修正后的正确信息)

湖南海利化工有限公司

Hunan Haili Chemical Industry Co., Ltd.

No. 251, 2nd Section, Furong(M) Road, Changsha, Hunan, China

TEL: 86-731-85357829 FAX: 86-731-85357977

装箱单

PACKING LIST

TO:

INVOICE NO.:

DATE:

S/C NO.:

FROM:

TO:

MARKS & NO.	DESCRIPTION S & PACKING	QTY	MEAS (M ³)	N.W. (KGS)	G.W. (KGS)
Total:					

SAY TOTAL :

HUNAN HAILI CHEMICAL INDUSTRY CO., LTD.

湖南海利化工有限公司

I 李灿娟

.....
(Authorized Signature)

- 3、请根据以上资料缮制保险单。（本题共 30 分）
（注：信用证的信息必须是修正后的正确信息）

中保财产保险有限公司

The People's Insurance (Property) Company of China Ltd.

发票号码

保险单号次

Invoice No.

Policy No.

海洋货物运输保险单

MARINE CARGO TRANSPORTATION INSURANCE POLICY

被保险人

Insured:

中保财产保险有限公司（以下简称本公司）根据被保险人的要求，及其所缴付约定的保险费，按照本保险单承担的险别和背面所载条款与下列特别条款承保下列货物运输保险，特签发本保单。

This policy of Insurance witnesses that The People's Insurance (Property) Company of China, Ltd. (hereinafter called "The company"), at the request of the Insured and consideration of the premium paid to The Company, undertakes to insure the under-mentioned goods in transportation subject to the condition of this Policy as per the Clauses printed overleaf and other special clauses attached hereon.

保险货物项目 Description of Goods	包装、单位、数量 Packing Unit Quantity	保险金额 Amount Insured

承保险别

货物标记

Condition

Marks of Goods

总保险金额:

Total Amount Insured

保费

运输工具

开航日期:

Premium As arranged **Per conveyance S.S**

Slg. On or abt

启运港

目的港

From

To

所保货物,如发生本保险合同单项下可能引起索赔的损失或损坏,应立即通知本公司下述代理人查勘,如有索赔,应向本公司提交保险单正本(本保险单共有 份正本)及有关文件。如一份正本已用于索赔,其余正本则自动失效。

In the event of loss or damage which may result in a claim under this Policy, immediate notice must be given to the Company's Agent as mentioned hereunder. Claims, if any, one of the Original Policy which has been issued in Original(s) together with the relevant documents shall be surrendered to the Company, if one of the Original Policy has been accomplished, the others to be void.

中保财产保险有限公司

The People's Insurance (Property) Company of China Ltd.

赔款偿付地点

Claim payable at

日期

Date

General Manager: 丁宁

地址:

Address:

4、请根据以上资料缮制产地证。(本题共 10 分)

(注: 信用证的信息必须是修正后的正确信息)

GENERALIZED SYSTEM OF PREFERENCES

CERTIFICATE OF ORIGIN (FORM A)

1. Goods consigned from: (Exporter's business name, address, country)		Reference No. Issued in _____(Country)			
2. Goods consigned to: (Consignee's name, address, country)		3. For official use			
4. Means of transport and route:					
7. Country/region of destination:	6. Marks and numbers of Packages:	7. Number and kind of packages; description of goods:	8. Origin criterion (see notes overleaf)	9. Gross weight or other quantity:	10. Number and date of invoices:

--	--	--	--	--	--

11. Declaration by the exporter :

The undersigned hereby declares that the above details and statements are correct: that all the goods were produced in

(Country)

and that they comply with the origin requirements specified for these goods in the Asia-Pacific Trade Agreement for goods exported to

(Importing Country)

HUNAN HAILI CHEMICAL INDUSTRY CO., LTD.

湖南海利化工有限公司

I **李灿明**

.....
(Authorized Signature)

Place and date, signature of authorized Signatory

12. Certificate

It is hereby certified on the basis of control carried out, that the declaration by the exporter is correct.



Place and date, signature and stamp of Certifying Authority

(2) 实施条件

项目	基本实施条件	备注
场地	每个商务英语实训室配置 40 个操作台面和座位，每个实训室照明通风良好。	必备
设备	每个商务英语实训室配有 1 台服务器、40—50 台计算机，并安装 Office 办公软件，配置局域网。	必备
测评专家	每 40 名考生配备 1 名考评员。考评员要求具备至少二年以上从事国际贸易工作经验或二年以上外贸单证缮制实践教学指导经历。	必备

(3) 考核时量

考核时间 90 分钟。

(4) 评分标准

模块总分	评价内容	配分		考核点	备注
岗位核心技能模块项目二：外贸单证缮制 (总分 100 分，占总评分的 50%)	职业素养与操作规范 (10 分)	职业素养 (6 分)	2 分	(1) 具备外贸从业人员基本素质，认真严谨、耐心细致、恪守信誉、实事求是、服从安排，听从指挥、举止文明；	在考试过程中不服从安排、举止不得当者，记 0 分。
			2 分	具备对外贸合同及信用证信息甄别正误及修正能力、正确缮制单证能力，做到数据计算准确、信息填写正确、单据填写完整；	与所述能力及素养不符，扣 1-2 分。
			2 分	(3) 具备正确规范操作外贸电商平台能力，具有对外贸产品筛选关键信息的能力，符合外贸行业对外贸电商运营等相关岗位需求。	与所述能力及素养不符，扣 1-2 分。
		操作规范 (4 分)	2 分	(1) 具备使用办公设备和 Office 办公软件的能力，在考核过程中以及考核结束后，不私自更换电脑、不随意关闭或重启电脑，没征求监考老师同意不随意提前或推迟交卷；	若私自更换电脑、随意关闭或重启电脑，记 0 分。

			2分	(2) 能严格遵守企业6S管理要求(整理、整顿、清扫、清洁、素养、安全)。	若未遵守企业6S管理要求,记0分。	
作品 (90分)	信用证 审核 (16分)		2分	(1) 买卖双方的名称与地址是否有误;	信用证审核共12个考核点,有8处错误,每处2分,找出错误计1分,修正错误计1分。	
			2分	(2) 品名、规格、数量、重量、单价是否有误;		
			2分	(3) 货物包装、体积是否有误;		
			2分	(4) 使用的贸易术语是否有误;		
			2分	(5) 合同金额和币种是否有误;		
			2分	(6) 合同中溢短装条款是否有误;		
			2分	(7) 唛头是否有误;		
			2分	(8) 起运港和目的港是否有误;		
			2分	(9) 分批装运和转运是否有误;		
			2分	(10) 保险险别、保险金额是否有误;		
			2分	(11) 最迟装运期是否有误;		
			2分	(12) 汇票的付款期限是否有误;单据条款是否有误。		
		装箱单 缮制 (34分)		2分	(1) 进口商名称和地址: 拼写准确无误;	装箱单缮制部分共17个考核点,每处计2分,未填、错填每处扣2分。拼写错误每3处扣1分。
			2分	(2) 商业发票号码: 填写准确无误;		
	2分		(3) 商业发票开立日期: 填写准确无误;			
	2分		(4) 合同号码: 填写准确无误;			
	2分		(5) 装运港: 填写准确无误;			
		2分	(6) 目的港: 填写准确无误;			
		2分	(7) 唛头: 描述准确无误;			
		2分	(8) 货物描述及包装: 品名及规格信息填写准确无误,计量数与外包装数关系表述准确无误;			

			2分	(9) 货物各自外包装总数量: 计算准确无误;	
			2分	(10) 货物各自总体积: 计算准确无误;	
			2分	(11) 货物各自总净重: 计算准确无误;	
			2分	(12) 货物各自总毛重: 计算准确无误;	
			2分	(13) 货物外包装总数量: 计算准确无误;	
			2分	(14) 货物总体积: 计算准确无误;	
			2分	(15) 货物总净重: 计算准确无误;	
			2分	(16) 货物总毛重: 计算准确无误;	
			2分	(17) 货物外包装总数量大写: 英文拼写正确。	
		保险单缮制 (30分)	2分	(1) 发票号码: 填写准确无误;	保险单缮制部分共15个考核点, 每处计2分, 未填、错填每处扣2分。拼写错误每3处扣1分。
			2分	(2) 保险单号次: 填写准确无误;	
			2分	(3) 被保险人公司名称和地址: 填写准确无误;	
			2分	(4) 被保险货物名称: 填写准确无误;	
			2分	(5) 外包装的数量和单位: 填写准确无误;	
			2分	(6) 保险金额阿拉伯数字小写: 计算准确无误, 填写正确;	
			2分	(7) 承保险别条款: 填写准确无误, 拼写正确;	
			2分	(8) 货物唛头: 填写准确无误;	
			2分	(9) 保险金额英文大写: 计算准确无误, 拼写正确;	
			2分	(10) 船名和航次: 填写准确无误;	
			2分	(11) 开航日期即提单日期: 填写准确无误;	

			2分	(12) 装运港: 填写准确无误;	
			2分	(13) 目的港: 填写准确无误;	
			2分	(14) 赔款偿付地点及币种: 填写准确无误;	
			2分	(15) 投保日期及地点: 填写准确无误.	
		产地证缮制 (10分)	1分	(1) 原产地证书编号: 填写准确无误;	产地证缮制部分共10个考核点, 每处计1分, 未填、错填每处扣1分。拼写错误每3处扣1分。
			1分	(2) 发货方: 名称、详细地址及国家(地区), 拼写准确无误;	
			1分	(3) 收货方: 最终收货方的名称、详细地址及国家(地区), 拼写准确无误;	
			1分	(4) 运输方式及路线: 起运港、目的港及运输方式, 填写准确无误;	
			1分	(5) 目的地国家(地区): 货物抵达的最终进口国(地区), 填写准确无误;	
			1分	(6) 唛头: 填写准确无误;	
			1分	(7) 包装数量及种类、货物描述: 拼写正确, 并在末行加上截止线;	
			1分	(8) 海关代码(一般原产地证)、原产地标准(普惠制产地证 Form A): 填写准确无误;	
			1分	(9) 所有商品总毛重或者其他数量: 数量计算准确。	
			1分	(10) 发票的号码和开立日期: 填写准确无误。	

16. 试题编号: 2-2-16 信用证审核、单证缮制

(1) 任务描述

任务 1: 信用证审核:

熟悉 UCP600 相关条款; 读懂外贸合同条款; 读懂并审核 L/C 各

条款；修改 L/C 中的问题条款。

注意：考试资料中的信用证为错误的信用证，考试中涉及到信用证的信息必须参考修改正确的信用证的信息，否则造成的制单错误将不计分。

任务 2：装箱单缮制

分析信用证中涉及装箱单缮制的相关条款；准确缮制装箱单；确保缮制的装箱单与信用证的条款一致。

任务 3：保险单缮制

分析信用证的保险条款；准确缮制保险单；确保缮制的保险单与信用证的条款一致。

任务 4：产地证缮制

分析信用证中涉及产地证缮制的相关条款；准确缮制产地证；确保缮制的产地证与信用证的条款一致。

背景资料

1、出口方基本情况

Company	SANY GROUP
Url	http://www.sanygroup.com/group/en-us/
Office Address	SANY INDUSTRY TOWN, ECONOMIC AND TECHNOLOGICAL DEVELOPMENT ZONE, CHANGSHA, HUNAN, CHINA
Zip code	410100
Phone	0086-21-20271802
Fax	0086-21-20271861
E-mail	crd@sany.com.cn

2、进口方基本情况

Company	MALI INTERNATIONAL AG.
---------	------------------------

Url	http://mali-group.visionline.ch/en/home/
Office Address	LANDSTRASSE 175, 5430 WETTINGEN, SWITZERLAND
Tollfree	无
Phone	+41 56 444 22 33
Fax	+41 56 444 22 30

3、合同

销售合同

SALES CONTRACT

SELLER: SANY GROUP
SANY INDUSTRY TOWN, ECONOMIC AND TECHNOLOGICAL DEVELOPMENT ZONE, CHANGSHA, HUNAN, CHINA
BUYER: MALI INTERNATIONAL AG.
LANDSTRASSE 175, 5430 WETTINGEN, SWITZERLAND

NO.: SY10904
DATE: SEPT. 04, 2022
SIGNED IN: CHANGSHA

This contract is made by and agreed between the BUYER and SELLER, in accordance with the terms and conditions stipulated below.

1. Commodity & Specification	2. Quantity	3. Unit Price & Trade Terms	4. Amount
CFR GOTHENBURG			
BEVEL GEAR MATERIAL:STEEL(A3/C45)	5,000 PCS	USD 2.5/PC	USD 12,500.00
Total:	5,000 PCS		USD 12,500.00

5. Total Value SAY U.S. DOLLARS TWELVE THOUSAND FIVE HUNDRED ONLY.

6. Packing PACKED IN STANDARD CARTONS, 20 PIECES PER CARTON
TOTAL: 250 CARTONS

7. Shipping Marks N/M

8. Time of Shipment & means of Transportation TO BE EFFECTED BEFORE THE END OF OCTOBER 2022 FROM SHANGHAI TO GOTHENBURG WITH TRANSSHIPMENT ALLOWED AND PARTIAL SHIPMENT NOT ALLOWED.

9. Port of Loading & Destination FROM: SHANGHAI
TO: GOTHENBURG

10. Insurance THE SELLER SHALL COVER INSURANCE AGAINST ALL RISKS & WAR RISK FOR 110% OF THE TOTAL INVOICE

VALUE AS PER THE RELEVANT OCEAN MARINE
CARGO OF P.I.C.C. DATED 1/1/1981
TO BE MADE BY SIGHT L/C

11. Terms of Payment

12. Remarks

The Buyer	The Seller
MALI INTER	SANY GROUP
NATIONAL AG.	
(signature)	(signature)

4、信用证

27:	SEQUENCE OF TOTAL	1/1
40A:	FORM OF DOCUMENTARY CREDIT	REVOCABLE
20:	DOCUMENTARY CREDIT NUMBER	290012/08
31C:	DATE OF ISSUE	220915
31D:	DATE AND PLACE OF EXPIRY	221121 SWITZERLAND
50:	APPLICANT	
	MALI INTERNATIONAL AG.	
	LANDSTRASSE 175, 5430 WETTINGEN, SWITZERLAND	
59:	BENEFICIARY	
	SANY GROUP	
	SANY INDUSTRY TOWN, ECONOMIC AND TECHNOLOGICAL ZONE, CHANGSHA,	
	HUNAN, CHINA.	
32B:	AMOUNT	USD 1,250.00
39B:	CREDIT AMT	NOT EXCEEDING
41D:	AVAILABLE WITH BY	ANY BANK IN CHINA
42C:	DRAFTS AT	30 DAYS AFTER SIGHT
42D:	DRAWEE	BARCLAYS BANK PLC SWITZERLAND BRANCH
43P:	PARTIAL SHIPMENTS	ALLOWED
43T:	TRANSSHIPMENT	ALLOWED
44A:	LOADING ON BOARD	SHANGHAI, CHINA
44B:	FOR TRANSPORTATION TO	GOTHENBURG, SWITZERLAND
44C:	LATEST DATE OF SHIPMENT	221031

- 45A: DESCRIPTION OF GOODS
5000 PCS BEVEL GEER
MATERIAL: STEEL(A3/C45)
USD 2.5/PC CIF GOTHENBURG
- 46A: DOCUMENTS REQUIRED
- +ORIGINAL SIGNED INVOICE PLUS THREE COPIES.
 - +PACKING LIST IN TRIPLICATE.
 - +CERTIFICATE OF ORIGIN GSP CHINA FORM A, ISSUED BY AUTHORITY DULY ENTITLED FOR THIS PURPOSE.
 - +FULL SET OF CLEAN ON BOARD OCEAN BILLS OF LADING, MADE OUT TO ORDER OF SHIPPER AND BLANK ENDORSED AND MARKED "FREIGHT PREPAID" AND NOTIFY APPLICANT.
 - +MARINE INSURANCE POLICY FOR 110PCT OF INVOICE VALUE, BLANK ENDORSED, COVERING ALL RISKS AND WAR RISK, CLAIMS PAYABLE AT DESTINATION.
 - +SHIPPING ADVICES MUST BE SENT TO APPLICANT ON THE DATE OF SHIPMENT ADVISING SHIPPING MARKS, COMMODITY NAME, CARTON NUMBERS, TOTAL GROSS WEIGHT, VESSEL NAME, BILL OF LADING NO., PORT OF LOADING, DESTINATION, CONTRACT NO., INVOICE NO., LETTER OF CREDIT NO.
 - +COPY OF LETTER FROM BENEFICIARY TO OUR APPLICANT EVIDENCING A NON NEGOTIABLE BILL OF LADING TOGETHER WITH COPY OF OTHER DOCUMENTS WAS SENT DIRECTLY TO THEM AFTER ONE DAY FROM SHIPMENT DATE.
- 71B: CHARGES ALL BANKING CHARGES OUTSIDE SWITZERLAND ARE FOR ACCOUNT OF APPLICANT.
- 48: PERIOD FOR PRESENTATION DOCUMENTS MUST BE PRESENTED WITHIN 15 DAYS AFTER THE DATE OF SHIPMENT BUT WITHIN THE VALIDITY OF THE CREDIT.

5、相关资料

(1) INVOICE NO.: SY39585

(2) INVOICE DATE: SEPTEMBER 25, 2022

(3) PACKING

PACKED IN STANDARD CARTONS, 20 PIECES PER CARTON

G. W.(KGS/CTN)	N. W.(KGS/CTN)	MEAS (CBM/CTN)
5.5	5.0	0.04

TOTAL ONE 20' CONTAINER

(4) VESSEL: VICTORY V. 0789

(5) B/L NO.: COCS00749

(6) B/L DATE: OCTOBER 15, 2022

(7) POLICY NO.: TY086899

(8) REFERENCE NO.: 20220925

抽考试题

1、请根据考试资料中的合同 3 审核错误的信用证 4，指出不符之处并修正。

(本题共 16 分)

1. _____
2. _____
3. _____
4. _____
5. _____
6. _____
7. _____
8. _____

2、请根据以上资料缮制装箱单。(本题共 34 分)

(注：信用证的信息必须是修正后的正确信息)

三一重工

Sany Group

Sany Industry Town, Economic and Technological Development Zone,

Changsha, Hunan, China

TEL: 0086-21-20271802 FAX: 0086-21-20271861

装箱单

PACKING LIST

TO:

INVOICE NO.:

DATE:

S/C NO.:

FROM:

TO:

MARKS & NO.	DESCRIPTION S & PACKING	QTY	MEAS (M³)	N.W. (KGS)	G.W. (KGS)
Total:					

SAY TOTAL :

SANY GROUP

I 三一重工

何浩斌

(Authorized Signature)

3、请根据以上资料缮制保险单。（本题共 30 分）

（注：信用证的信息必须是修正后的正确信息）

中保财产保险有限公司

The People's Insurance (Property) Company of China Ltd.

发票号码

保险单号次

Invoice No.

Policy No.

海洋货物运输保险单

MARINE CARGO TRANSPORTATION INSURANCE POLICY

被保险人

Insured:

中保财产保险有限公司（以下简称本公司）根据被保险人的要求，及其所缴付约定的保险费，按照本保险单承担的险别和背面所载条款与下列特别条款承保下列货物运输保险，特签发本保单。

This policy of Insurance witnesses that The People's Insurance (Property) Company of China, Ltd. (hereinafter called "The company"), at the request of the Insured and consideration of the premium paid to The Company, undertakes to insure the under-mentioned goods in transportation subject to the condition of this Policy as per the Clauses printed overleaf and other special clauses attached hereon.

保险货物项目 Description of Goods	包装、单位、数量 Packing Unit Quantity	保险金额 Amount Insured

承保险别

货物标记

Condition

Marks of Goods

总保险金额:

Total Amount Insured

保费

运输工具

开航日期:

Premium As arranged **Per conveyance S.S**

Slg. On or abt

启运港

目的港

From

To

所保货物,如发生本保险合同单项下可能引起索赔的损失或损坏,应立即通知本公司下述代理人查勘,如有索赔,应向本公司提交保险单正本(本保险单共有 份正本)及有关文件。如一份正本已用于索赔,其余正本则自动失效。

In the event of loss or damage which may result in a claim under this Policy, immediate notice must be given to the Company's Agent as mentioned hereunder. Claims, if any, one of the Original Policy which has been issued in Original(s) together with the relevant documents shall be surrendered to the Company, if one of the Original Policy has been accomplished, the others to be void.

中保财产保险有限公司

The People's Insurance (Property) Company of China Ltd.

赔款偿付地点

Claim payable at

日期

Date

General Manager: 丁宁

地址:

Address:

- 4、请根据以上资料缮制产地证。（本题共 10 分）
（注：信用证的信息必须是修正后的正确信息）

GENERALIZED SYSTEM OF PREFERENCES

CERTIFICATE OF ORIGIN (FORM A)

1. Goods consigned from: (Exporter's business name, address, country)			Reference No. Issued in _____(Country)		
2. Goods consigned to: (Consignee's name, address, country)			3. For official use		
4. Means of transport and route:					
8. Country/ region of destination:	6. Marks and numbers of Packages:	7. Number and kind of packages; description of goods:	8. Origin criterion (see notes overleaf)	9. Gross weight or other quantity:	10. Number and date of invoices:
11. Declaration by the exporter : The undersigned hereby declares that the above details and statements are correct: that all the goods			12. Certificate It is hereby certified on the basis of control carried out, that the declaration by the exporter		

<p>were produced in</p> <p style="text-align: center;">(Country)</p> <p>and that they comply with the origin requirements specified for these goods in the Asia-Pacific Trade Agreement for goods exported to</p> <p style="text-align: center;">(Importing Country)</p> <p style="text-align: center;">SANY GROUP</p> <p style="text-align: center;">I 三一重工</p> <p style="text-align: center;">何浩威</p> <p style="text-align: center;">(Authorized Signature)</p> <p>Place and date, signature of authorized Signatory</p>	<p>is correct.</p> <div style="text-align: center;">  </div> <p>Place and date, signature and stamp of Certifying Authority</p>
--	---

(2) 实施条件

项目	基本实施条件	备注
场地	每个商务英语实训室配置 40 个操作台面和座位，每个实训室照明通风良好。	必备
设备	每个商务英语实训室配有 1 台服务器、40—50 台计算机，并安装 Office 办公软件，配置局域网。	必备
测评专家	每 40 名考生配备 1 名考评员。考评员要求具备至少二年以上从事国际贸易工作经验或二年以上外贸单证缮制实践教学指导经历。	必备

(3) 考核时量

考核时间 90 分钟。

(4) 评分标准

模块总分	评价内容	配分		考核点	备注
岗位核心 技能模块项 目二： 外贸单证 缮制 (总分 100 分，占总评 分的 50%)	职业素养 与 操作规范 (10分)	职业素养 (6分)	2分	(1) 具备外贸从业人员基本素质，认真严谨、耐心细致、恪守信誉、实事求是、服从安排，听从指挥、举止文明；	在考试过程中不服从安排、举止不得当者，记 0 分。
			2分	具备对外贸合同及信用证信息甄别正误及修正能力、正确缮制单证能力，做到数据计算准确、信息填写正确、单据填写完整；	与所述能力及素养不符，扣 1-2 分。
			2分	(3) 具备正确规范操作外贸电商平台能力，具有对外贸产品筛选关键信息的能力，符合外贸行业对外贸电商运营等相关岗位需求。	与所述能力及素养不符，扣 1-2 分。
		操作规范 (4分)	2分	(1) 具备使用办公设备和 Office 办公软件的能力，在考核过程中以及考核结束后，不私自更换电脑、不随意关闭或重启电脑，没征求监考老师同意不随意提前或推迟交卷；	若私自更换电脑、随意关闭或重启电脑，记 0 分。
			2分	(2) 能严格遵守企业 6S 管理要求（整理、整顿、清扫、清洁、素养、安全）。	若未遵守企业 6S 管理要求，记 0 分。
		作品 (90分)	信用证 审核 (16分)	2分	(1) 买卖双方的名称与地址是否有误；
	2分			(2) 品名、规格、数量、重量、单价是否有误；	
	2分			(3) 货物包装、体积是否有误；	
	2分			(4) 使用的贸易术语是否有误；	
	2分			(5) 合同金额和币种是否有误；	
	2分			(6) 合同中溢短装条款是否有误；	
	2分			(7) 唛头是否有误；	
	2分			(8) 起运港和目的港是否有误；	
	2分	(9) 分批装运和转运是否有误；			

			2分	(10) 保险险别、保险金额是否有误;	
			2分	(11) 最迟装运期是否有误;	
			2分	(12) 汇票的付款期限是否有误; 单据条款是否有误。	
		装箱单缮制 (34分)	2分	(1) 进口商名称和地址: 拼写准确无误;	装箱单缮制部分共17个考核点, 每处计2分, 未填、错填每处扣2分。拼写错误每3处扣1分。
			2分	(2) 商业发票号码: 填写准确无误;	
			2分	(3) 商业发票开立日期: 填写准确无误;	
			2分	(4) 合同号码: 填写准确无误;	
			2分	(5) 装运港: 填写准确无误;	
			2分	(6) 目的港: 填写准确无误;	
			2分	(7) 唛头: 描述准确无误;	
			2分	(8) 货物描述及包装: 品名及规格信息填写准确无误, 计量数与外包装数关系表述准确无误;	
			2分	(9) 货物各自外包装总数量: 计算准确无误;	
			2分	(10) 货物各自总体积: 计算准确无误;	
			2分	(11) 货物各自总净重: 计算准确无误;	
			2分	(12) 货物各自总毛重: 计算准确无误;	
			2分	(13) 货物外包装总数量: 计算准确无误;	
			2分	(14) 货物总体积: 计算准确无误;	
			2分	(15) 货物总净重: 计算准确无误;	
			2分	(16) 货物总毛重: 计算准确无误;	
			2分	(17) 货物外包装总数量大写: 英文拼写正确。	
		保险单	2分	(1) 发票号码: 填写准确无误;	保险单缮制部

		缮制 (30分)	2分	(2) 保险单号次: 填写准确无误;	分共15个考核点, 每处计2分, 未填、错填每处扣2分。拼写错误每3处扣1分。
			2分	(3) 被保险人公司名称和地址: 填写准确无误;	
			2分	(4) 被保险货物名称: 填写准确无误;	
			2分	(5) 外包装的数量和单位: 填写准确无误;	
			2分	(6) 保险金额阿拉伯数字小写: 计算准确无误, 填写正确;	
			2分	(7) 承保险别条款: 填写准确无误, 拼写正确;	
			2分	(8) 货物唛头: 填写准确无误;	
			2分	(9) 保险金额英文大写: 计算准确无误, 拼写正确;	
			2分	(10) 船名和航次: 填写准确无误;	
			2分	(11) 开航日期即提单日期: 填写准确无误;	
			2分	(12) 装运港: 填写准确无误;	
			2分	(13) 目的港: 填写准确无误;	
			2分	(14) 赔款偿付地点及币种: 填写准确无误;	
			2分	(15) 投保日期及地点: 填写准确无误。	
1分	(2) 发货方: 名称、详细地址及国家(地区), 拼写准确无误;				
1分	(3) 收货方: 最终收货方的名称、详细地址及国家(地区), 拼写准确无误;				
1分	(4) 运输方式及路线: 起运港、目的港及运输方式, 填写准确无误;				
1分	(5) 目的地国家(地区): 货物抵达的最				

				终进口国（地区），填写准确无误；	
			1分	（6）唛头：填写准确无误；	
			1分	（7）包装数量及种类、货物描述：拼写正确，并在末行加上截止线；	
			1分	（8）海关代码（一般原产地证）、原产地标准（普惠制产地证 Form A）：填写准确无误；	
			1分	（9）所有商品总毛重或者其他数量：数量计算准确。	
			1分	（10）发票的号码和开立日期：填写准确无误。	

17. 试题编号：2-2-17 合同审核、单证缮制

（1）任务描述

任务 1：合同审核

读懂谈判备忘录的内容；读懂并审核合同各条款；修改合同中的问题条款。

注意：考试资料中的合同为错误的合同，考试中涉及到合同的信息必须参考修改正确的合同的信息，否则造成的制单错误将不计分。

任务 2：商业发票缮制

分析合同中涉及商业发票缮制的相关条款；准确缮制商业发票；确保缮制的商业发票与合同的条款一致。

任务 3：保险单缮制

分析信用证的保险条款；准确缮制保险单；确保缮制的保险单与

信用证的条款一致。

任务 4： 汇票缮制

分析合同中涉及汇票缮制的相关条款；准确缮制汇票；确保缮制的汇票与合同的条款一致。

背景资料

1、 出口方基本情况

Company	BROAD AIR QUALITY TECHNOLOGY GROUP
Url	http://www.broad.com:8089/english/
Office Address	YUANDA TOWN, YUANDA 3RD ROAD, CHANGSHA, HUNAN, CHINA
Zip code	410138
Phone	86-731-84086688
Fax	86-731-84610087
E-mail	international@broad.net

2、 进口方基本情况

Company	GALAXY REFRIGERATION PRIVATE LIMITED CO.
Url	http://www.galaxyintl.com/
Office Address	NO. D-8, SHANTI KUNJ, NEAR CHURCH, VASANT KUNJ, NEW DELHI, INDIA
Tollfree	+(91)-9810008066
Phone	+(91)-(11)-26130435/ 26130436
Fax	+(91)-(11)-26130436

3、 谈判备忘录

Minutes of a Meeting	
TIME:	May 07-12, 2022
PLACE:	Conference Room of Hunan Hotel, Changsha, Hunan, China
PURPOSE:	To come to an agreement over the transaction of the interested products.
PRESIDING:	Mr. Zhanghui

	(Party A: Sales Manager of Broad Air Quality Technology Group))						
PRESENT:	Mr. Jeton Sagan (Party B: Purchasing Manager of Galaxy Refrigeration Private Limited Co.)						
SUMMARY OF THE MEETING							
<p>After several rounds of negotiation, Party A and Party B come to terms on May 12 over the transaction of Two-Way Motor Valve. A brief summary of the meeting is as follows:</p>							
<p>1. Name of commodity and specifications:</p> <p style="padding-left: 40px;">Two-Way Motor Valve</p> <p style="padding-left: 40px;">Bvs20-2-16 Valve (20 mm)</p> <p style="padding-left: 40px;">Bvs125-2-16 Valve (125 mm)</p>							
<p>2. Packing: Each product shall be packed in a plastic bag and each in</p> <p style="padding-left: 80px;">a carton box.</p> <p style="padding-left: 80px;">All in 1120 boxes</p>							
<p>3. Weight and measurement:</p> <p style="padding-left: 40px;">G. W.: 26 KGS/BOX</p> <p style="padding-left: 40px;">N. W.: 22 KGS/BOX</p> <p style="padding-left: 40px;">MEAS: 0.2 CBM/ BOX</p> <p style="padding-left: 40px;">PACKED IN 1120 BOXES</p>							
<p>4. Shipping marks: GALAXY REFRIGERATION</p> <p style="padding-left: 80px;">BR110530RE</p> <p style="padding-left: 80px;">NO. 1-1120</p>							
<p>5. Unit price and quantity: CIF NEW DELHI</p> <table style="width: 100%; border-collapse: collapse;"> <tr> <td style="padding-left: 40px;">BVS20-2-16 VALVE (20 MM)</td> <td style="padding-left: 40px;">USD 198.00/PC</td> <td style="text-align: right;">510 PCS</td> </tr> <tr> <td style="padding-left: 40px;">BVS125-2-16 VALVE (125 MM)</td> <td style="padding-left: 40px;">USD 328.00/PC</td> <td style="text-align: right;">610 PCS</td> </tr> </table>		BVS20-2-16 VALVE (20 MM)	USD 198.00/PC	510 PCS	BVS125-2-16 VALVE (125 MM)	USD 328.00/PC	610 PCS
BVS20-2-16 VALVE (20 MM)	USD 198.00/PC	510 PCS					
BVS125-2-16 VALVE (125 MM)	USD 328.00/PC	610 PCS					
<p>6. Time and terms of shipment:</p> <p style="padding-left: 40px;">To be shipped within 60 days after the contract is signed.</p> <p style="padding-left: 40px;">Transshipment is allowed, but partial shipment is not allowed.</p>							
<p>7. Ports of loading and destination: From Guangzhou to New Delhi</p>							
<p>8. Insurance: To be covered against All Risks and S.R.C.C.</p>							

9. Terms of payment: 20% by T/T as prepayment and 80% by D/P at sight 10. Documents:
- Commercial Invoice in triplicate.
 - Packing List in triplicate
 - Full set of clean on board ocean bills of lading, made out to order of shipper and blank endorsed and marked "freight prepaid" and notify the buyer.
 - Shipping advice must be sent to buyer on the date of shipment advising shipping marks, commodity name, carton numbers, total gross weight, vessel name, bill of lading No., port of loading, destination, contract No. and invoice No.
 - Certificate of Origin in duplicate.
 - Insurance policy/certificate blank endorsed covering All Risks and S.R.C.C. for 110% of the total invoice value.

4、合同

销售合同

SALES CONTRACT

SELLER: BROAD AIR QUALITY TECHNOLOGY GROUP NO.: BR110530RE
 YUANDA TOWN, YUANDA 3RD ROAD, DATE: MAY 30, 2021
 CHANGSHA, HUNAN, CHINA SIGNED IN: CHANGSHA

BUYER: GALAXY REFRIGERATION PRIVATE LIMITED CO.
 NO. D-8, SHANTI KUNJ, NEAR CHURCH, VASANT KUNJ, NEW DELHI, INDIA

This contract is made by and agreed between the BUYER and SELLER, in accordance with the terms and conditions stipulated below.

1. Commodity & Specification	2. Quantity	3. Unit Price & Trade Terms	4. Amount
CFR NEW DELHI			
TWO-WAY MOTOR VALVE BVS20-2-16 VALVE (20 MM)	510 PCS	USD 198.00/PC	USD 100,980.00
BVS125-2-16 VALVE (125 MM)	610 PCS	USD 328.00/PC	USD 200,080.00
Total:	1,110 PCS		USD 301,060.00

5. Total Value SAY U.S. DOLLARS THREE HUNDRED THOUSAND SIXTY ONLY.

6. Packing EACH PRODUCT SHALL BE PACKED IN A PLASTIC BAG AND EACH IN A CARTON BOX. ALL IN 1120 BOXES.

7. Shipping Marks GALAXY REFRIGERATION
BR110530
NO. 1-1120

8. Time of Shipment & means of Transportation TO BE EFFECTED BEFORE JULY 30, 2022 FROM GUANGZHOU TO NEW DELHI WITH PARTIAL SHIPMENT AND TRANSSHIPMENT NOT ALLOWED.

12. Port of Loading & Destination FROM: GUANGZHOU
TO: NEW YORK

10. Insurance THE SELLER SHALL COVER THE GOODS AGAINST ALL RISKS AND S.R.C.C. FOR 110% OF THE TOTAL INVOICE VALUE AS PER THE RELEVANT OCEAN MARINE CARGO OF P.I.C.C. DATED 1/1/1981

11. Terms of Payment 20% BY T/T AS PREPAYMENT AND 80% BY D/P 30 DAYS AFTER SIGHT.

12. Remarks

The Buyer	The Seller
GALAXY REFRIGERATION PRIVATE LIMITED CO.	BROAD AIR QUALITY TECHNOLOGY GROUP
(signature)	(signature)

5、相关资料

(1) INVOICE NO.: BR012308AQ

(2) INVOICE DATE: JUNE 15, 2022

(3) PACKING

G. W.(KGS/BOX)	N. W.(KGS/BOX)	MEAS (CBM/BOX)
26	22	0.2

PACKED IN 1120 BOXES
TOTAL EIGHT 20' CONTAINERS

(4) VESSEL: SHANSHUI09-11

(5) B/L NO.: COS7246-20DC

(6) B/L DATE: JULY 20, 2022

(7) POLICY NO.: PICC113C3F

(8) REFERENCE NO.: 13RCER89

(9) H.S. CODE: 7320209000

(10) COLLECTING BANK: BANK OF CHINA, HUNAN BRANCH

抽考试题

1、请根据考试资料中的谈判备忘录 3 审核错误的合同 4，指出不符之处并修正。

(本题共 16 分)

1. _____
2. _____
3. _____
4. _____
5. _____
6. _____
7. _____
8. _____

2、请根据以上资料缮制商业发票。(本题共 34 分)

(注：合同的信息必须是修正后的正确信息)

远大集团

Broad Air Quality Technology Group

Yunda Town, Yuanda 3rd Road, Changsha, Hunan, China

TEL: 86-731-84086688 FAX: 86-731-84610087

商业发票

COMMERCIAL INVOICE

TO:		INVOICE NO.:		
		INVOICE DATE:		
		S/C NO.:		
		S/C DATE:		
FROM:		TO:		
Marks and Numbers	Description of Goods	Quantity	Unit Price	Amount

Total:				

SAY TOTAL :

BROAD AIR QUALITY TECHNOLOGY GROUP

远大集团

陈洁

(Authorized Signature)

- 3、请根据以上资料缮制保险单。（本题共 30 分）
（注：合同的信息必须是修正后的正确信息）

中保财产保险有限公司

The People's Insurance (Property) Company of China Ltd.

发票号码

保险单号次

Invoice No.

Policy No.

海洋货物运输保险单

MARINE CARGO TRANSPORTATION INSURANCE POLICY

被保险人

Insured:

中保财产保险有限公司（以下简称本公司）根据被保险人的要求，及其所缴付约定的保险费，按照本保险单承担的险别和背面所载条款与下列特别条款承保下列货物运输保险，特签发本保单。

This policy of Insurance witnesses that The People's Insurance (Property) Company of China, Ltd. (hereinafter called "The company"), at the request of the Insured and consideration of the premium paid to The Company, undertakes to insure the under-mentioned goods in transportation subject to the condition of this Policy as per the Clauses printed overleaf and other special clauses attached hereon.

保险货物项目 Description of Goods	包装、单位、数量 Parking Unit Quantity	保险金额 Amount Insured
--------------------------------	-----------------------------------	------------------------

--	--	--

承保险别

货物标记

Condition

Marks of Goods

总保险金额:

Total Amount Insured

保费

运输工具

开航日期:

Premium

As arranged

Per conveyance S.S

Slg. On or abt

启运港

目的港

From

To

所保货物,如发生本保险合同单项下可能引起索赔的损失或损坏,应立即通知本公司下述代理人查勘,如有索赔,应向本公司提交保险单正本(本保险单共有 份正本)及有关文件。如一份正本已用于索赔,其余正本则自动失效。

In the event of loss or damage which may result in a claim under this Policy, immediate notice must be given to the Company's Agent as mentioned hereunder. Claims, if any, one of the Original Policy which has been issued in Original(s) together with the relevant documents shall be surrendered to the Company, if one of the Original Policy has been accomplished, the others to be void.

中保财产保险有限公司

The People's Insurance (Property) Company of China Ltd.

赔款偿付地点

Claim payable at

日期

Date

General Manager: 张洋

地址:

Address:

4、请根据以上资料缮制 D/P 项下的汇票。（本题共 10 分）
（注：合同的信息必须是修正后的正确信息）

BILL OF EXCHANGE

Drawn under _____

L/C No. _____

Dated _____

No. _____ Exchange for _____

Changsha, China. _____ D/P At _____ sight of this

FIRST of Exchange

(Second of exchange being unpaid)

Pay to the order of _____

The sum of _____

To _____

BROAD AIR QUALITY TECHNOLOGY GROUP

远大集团

陈洁

.....
(Authorized Signature)

(2) 实施条件

项目	基本实施条件	备注
场地	每个商务英语实训室配置 40 个操作台面和座位，每个实训室照明通风良好。	必备
设备	每个商务英语实训室配有 1 台服务器、40—50 台计算机，并安装 Office 办公软件，配置局域网。	必备
测评专家	每 40 名考生配备 1 名考评员。考评员要求具备至少二年以上从事国际贸易工作经验或二年以上外贸单证缮制实践教学指导经历。	必备

(3) 考核时量

考核时间 90 分钟。

(4) 评分标准

模块总分	评价内容	配分	考核点	备注	
岗位核心 技能模块项 目二： 外贸单证 缮制 (总分 100 分，占总评 分的 50%)	职业素养 与 操作规范 (10分)	职业素养 (6分)	2分	(1) 具备外贸从业人员基本素质，认真严谨、耐心细致、恪守信誉、实事求是、服从安排，听从指挥、举止文明；	在考试过程中不服从安排、举止不得当者，记 0 分。
			2分	具备对外贸合同及信用证信息甄别正误及修正能力、正确缮制单证能力，做到数据计算准确、信息填写正确、单据填写完整；	与所述能力及素养不符，扣 1-2 分。
			2分	(3) 具备正确规范操作外贸电商平台能力，具有对外贸产品筛选关键信息的能力，符合外贸行业对外贸电商运营等相关岗位需求。	与所述能力及素养不符，扣 1-2 分。
		操作规范 (4分)	2分	(1) 具备使用办公设备和 Office 办公软件的能力，在考核过程中以及考核结束后，不私自更换电脑、不随意关闭或重启电脑，没征求监考老师同意不随意提前或推迟交卷；	若私自更换电脑、随意关闭或重启电脑，记 0 分。
			2分	(2) 能严格遵守企业 6S 管理要求（整理、整顿、清扫、清洁、素养、安全）。	若未遵守企业 6S 管理要求，记 0 分。
			合同审核 (16分)	2分	(1) 买卖双方的名称与地址是否有误；
	2分	(2) 品名、规格、数量、重量、单价是否有误；			
	2分	(3) 货物包装、体积是否有误；			
	2分	(4) 使用的贸易术语是否有误；			
	2分	(5) 合同金额和币种是否有误；			
2分	(6) 合同中溢短装条款是否有误；				

			2分	(7) 唛头是否有误;	
			2分	(8) 起运港和目的港是否有误;	
			2分	(9) 分批装运和转运是否有误;	
			2分	(10) 保险险别、保险金额是否有误;	
			2分	(11) 最迟装运期是否有误;	
			2分	(12) 汇票的付款期限是否有误。	
		商业发票缮制 (34分)	2分	(1) 进口商名称和地址: 拼写准确无误;	商业发票缮制部分共 17 个考核点, 每处计 2 分, 未填、错填每处扣 2 分。拼写错误每 3 处扣 1 分。
			2分	(2) 商业发票号码: 填写准确无误;	
			2分	(3) 商业发票开立日期: 填写准确无误;	
			2分	(4) 合同号码: 填写准确无误;	
			2分	(5) 信用证号码: 填写准确无误;	
			2分	(6) 信用证日期: 填写准确无误;	
			2分	(7) 运输路线装运地: 填写准确无误;	
			2分	(8) 运输路线目的地: 填写准确无误;	
			2分	(9) 价格术语: 填写准确无误;	
			2分	(10) 货物唛头: 填写准确无误;	
			2分	(11) 货物描述: 品名拼写正确, 规格信息填写准确无误;	
			2分	(12) 货物数量: 填写准确无误;	
			2分	(13) 货物单价及单位: 填写准确无误;	
			2分	(14) 货物金额: 填写准确无误;	
			2分	(15) 货物数量总计: 计算准确无误;	
			2分	(16) 货物金额总计: 计算准确无误, 货币名称正确;	
			2分	(17) 总金额大写: 英文拼写正确。	

保险单缮制 (30分)	2分	(1) 发票号码: 填写准确无误;	保险单缮制部分共15个考核点, 每处计2分, 未填、错填每处扣2分。拼写错误每3处扣1分。
	2分	(2) 保险单号次: 填写准确无误;	
	2分	(3) 被保险人公司名称和地址: 填写准确无误;	
	2分	(4) 被保险货物名称: 填写准确无误;	
	2分	(5) 外包装的数量和单位: 填写准确无误;	
	2分	(6) 保险金额阿拉伯数字小写: 计算准确无误, 填写正确;	
	2分	(7) 承保险别条款: 填写准确无误, 拼写正确;	
	2分	(8) 货物唛头: 填写准确无误;	
	2分	(9) 保险金额英文大写: 计算准确无误, 拼写正确;	
	2分	(10) 船名和航次: 填写准确无误;	
	2分	(11) 开航日期即提单日期: 填写准确无误;	
	2分	(12) 装运港: 填写准确无误;	
	2分	(13) 目的港: 填写准确无误;	
	2分	(14) 赔款偿付地点及币种: 填写准确无误;	
	2分	(15) 投保日期及地点: 填写准确无误。	
汇票缮制 (10分)	1分	(1) 出票条款: 开证行完整名称, 拼写准确无误;	汇票缮制部分共10个考核点, 每处计1分, 未填、错填每处扣1分。拼写错误每3处扣1分。
	1分	(2) 信用证号码: 填写准确无误;	
	1分	(3) 信用证开证日期: 填写准确无误;	
	1分	(4) 汇票号码: 填写准确无误;	
	1分	(5) 汇票日期: 填写准确无误;	

			1分	(6) 汇票金额小写：填写准确无误；	
			1分	(7) 汇款期限：填写准确无误；	
			1分	(8) 收款人：信用证下以议付行为收款人，托收汇票下以托收行（出口地银行）为收款人：信息完整无误，拼写正确；	
			1分	(9) 金额及币种大写：币种与金额必须与信用证保持一致，拼写准确无误；	
			1分	(10) 付款人：信用证项下付款人为开证行或指定银行：信息完整无误，拼写正确。	

18. 试题编号：2-2-18 合同审核、单证缮制

(1) 任务描述

任务 1：合同审核

读懂谈判备忘录的内容；读懂并审核合同各条款；修改合同中的问题条款。

注意：考试资料中的合同为错误的合同，考试中涉及到合同的信息必须参考修改正确的合同的信息，否则造成的制单错误将不计分。

任务 2：商业发票缮制

分析合同中涉及商业发票缮制的相关条款；准确缮制商业发票；确保缮制的商业发票与合同的条款一致。

任务 3：保险单缮制

分析信用证的保险条款；准确缮制保险单；确保缮制的保险单与信用证的条款一致。

任务 4：汇票缮制

分析合同中涉及汇票缮制的相关条款；准确缮制汇票；确保缮制的汇票与合同的条款一致。

背景资料

1、出口方基本情况

Company	HUNAN HAILI CHEMICAL INDUSTRY CO., LTD. (Hunan Haili)
Url	http://www.hnhlc.com
Office Address	NO. 251, 2ND SECTION, FURONG(M) ROAD, CHANGSHA, HUNAN, CHINA
Zip code	410007
Phone	86-731-85357829
Fax	86-731-85357977
E-mail	sh600731@sina.com

2、进口方基本情况

Company	DEVIDAYAL (SALES) LIMITED
Url	http://www.devidayalagro.com/
Office Address	1ST FLOOR DEVIDAYAL ESTATE, REAY ROAD, MUMBAI 400010, INDIA
E-mail	bombay@devidayalagro.com
Phone	+(91)-(11)-26130435/ 26130436
Fax	+(91)-(11)-26130436

3、谈判备忘录

Minutes of a Meeting	
TIME:	Apr. 18-20, 2022
PLACE:	Conference Room of Huatian Hotel, Changsha, Hunan, China
PURPOSE:	To come to an agreement over the transaction of the interested products.
PRESIDING:	Mr. Litong (Party A: Sales Manager of Hunan Haili Chemical Industry Co., Ltd.)

PRESENT:	Mr. Henry Link (Party B: Purchasing Manager of Devidayal (Sales) Limited)
----------	---

SUMMARY OF THE MEETING

After several rounds of negotiation, Party A and Party B come to terms on April 20 over the transaction of 150 drums of CARBOFURAN and 100 drums of Carbosulfan. A brief summary of the meeting is as follows:

1. Name of commodity and specifications:

CARBOFURAN, CARBOSULFAN

2. Packing: To be packed in drums.

3. Weight and measurement:

G.W.: 20 KGS/DRUM

N.W.: 18 KGS/DRUM

MEAS: 0.2 CBM/DRUM

4. Shipping marks: MUMBAI

RT08215

NO. 1-250

5. Unit price and quantity: CIF MUMBAI

CARBOFURAN 150 DRUMS USD 80/DRUM

CARBOSULFAN 100 DRUMS USD 100/DRUM

6. Time and terms of shipment:

To be shipped within 45 days after the contract is signed.

Transshipment is not allowed, but partial shipment is allowed.

7. Ports of loading and destination: From Shanghai to Mumbai

8. Insurance: To be covered against All Risks and War Risk.

9. Terms of payment: by D/P at sight

10. Documents:

- Commercial Invoice in triplicate.

- Packing List in triplicate

- Full set of clean on board ocean bills of lading, made out to order of shipper and

blank endorsed and marked "freight prepaid" and notify the buyer.

- Shipping advice must be sent to buyer on the date of shipment advising shipping marks, commodity name, carton numbers, total gross weight, vessel name, bill of lading No., port of loading, destination, contract No. and invoice No.

- Certificate of Origin in duplicate.

- Insurance policy/certificate blank endorsed covering All Risks and War Risk for 110% of the total invoice value.

4、合同

销售合同

SALES CONTRACT

SELLER: HUNAN HAILI CHEMICAL INDUSTRY CO., LTD. **NO.:** RT08215
NO. 251, 2ND SECTION, FURONG(M) ROAD, **DATE:** APR.20, 2022
CHANGSHA, HUNAN, CHINA **SIGNED IN:** CHANGSHA

BUYER: DEVDAYAL (SALES) LIMITED 1ST FLOOR DEVIDAYAL ESTATE, REAY
ROAD, MUMBAI 400010, I
NDIA

This contract is made by and agreed between the BUYER and SELLER, in accordance with the terms and conditions stipulated below.

1. Commodity & Specification	2. Quantity	3. Unit Price & Trade Terms	4. Amount
			CFR MUMBAI
CARBOFURAN	150 DRUMS	USD 80/DRUM	USD 12,000.00
CARBOSULFAN	100 DRUMS	USD 100/DRUM	USD 10,000.00
Total:	250 DRUMS		USD 22,000.00

5. Total Value SAY U.S. DOLLARS TWENTY TWO THOUSAND ONLY.

6. Packing G. W.: 20 KGS/DRUM
N. W.: 18 KGS/DRUM
MEAS: 0.2 CBM/DRUM
PACKED IN 250 DRUMS
CHANGSHA

7. Shipping Marks RT08215
NO. 1-250

- 8. Time of Shipment & means of Transportation** TO BE EFFECTED BEFORE JUNE 4, 2022 FROM SHANGHAI TO MUMBAI WITH PARTIAL SHIPMENT AND TRANSSHIPMENT ALLOWED.
- 13. Port of Loading & Destination** FROM: CHANGSHA
TO: MUMBAI
- 10. Insurance** THE SELLER SHALL COVER INSURANCE AGAINST ALL RISKS & WAR RISK FOR 130% OF THE TOTAL INVOICE VALUE AS PER THE RELEVANT OCEAN MARINE CARGO OF P.I.C.C. DATED 1/1/1981
- 11. Terms of Payment** TO BE MADE BY T/T
- 12. Remarks**

The Buyer	The Seller
DEVIDAYAL(SALES) LIMITED	HUNAN HAILI CHEMICAL INDUSTRY CO., LTD.
(signature)	(signature)

5、相关资料

(1) INVOICE NO.: XH65472

(2) INVOICE DATE: MAY 5, 2022

(3) PACKING

G. W.(KGS/DRUM)	N. W.(KGS/DRUM)	MEAS (CBM/DRUM)
20	18	0.2

PACKED IN 250 DRUMS TOTAL ONE 40' CONTAINER

(4) VESSEL: NANGXING V. 052

(5) B/L NO.: COCS0516427

(6) B/L DATE: MAY 30, 2022

(7) POLICY NO.: SH110618

(8) CERTIFICATE NO.: 20220527

(9) H.S. CODE: 1302199012

(10) COLLECTING BANK: BANK OF CHINA, HUNAN BRANCH

抽考试题

1、请根据考试资料中的谈判备忘录 3 审核错误的合同 4，指出不符之处并修正。

(本题共 16 分)

1. _____
2. _____
3. _____
4. _____
5. _____
6. _____
7. _____
8. _____

2、请根据以上资料缮制商业发票。(本题共 34 分)

(注: 合同的信息必须是修正后的正确信息)

湖南海利化工有限公司

Hunan Haili Chemical Industry Co., Ltd.

No. 251, 2nd Section, Furong (M) Road, Changsha, Hunan, China

TEL: 86-731-85357829 FAX: 86-731-85357977

商业发票

COMMERCIAL INVOICE

TO:		INVOICE NO.:		
		INVOICE DATE:		
		S/C NO.:		
		S/C DATE:		
FROM:		TO:		
Marks and Numbers	Description of Goods	Quantity	Unit Price	Amount
Total:				

SAY TOTAL :

HUNAN HAILI CHEMICAL INDUSTRY CO., LTD.

湖南海利化工有限公司

李灿明

(Authorized Signature)

3、请根据以上资料缮制保险单。（本题共 30 分）

（注：合同的信息必须是修正后的正确信息）

中保财产保险有限公司

The People's Insurance (Property) Company of China Ltd.

发票号码

保险单号次

Invoice No.

Policy No.

海洋货物运输保险单

MARINE CARGO TRANSPORTATION INSURANCE POLICY

被保险人

Insured:

中保财产保险有限公司（以下简称本公司）根据被保险人的要求，及其所缴付约定的保险费，按照本保险单承担的险别和背面所载条款与下列特别条款承保下列货物运输保险，特签发本保单。

This policy of Insurance witnesses that The People's Insurance (Property) Company of China, Ltd. (hereinafter called "The company"), at the request of the Insured and consideration of the premium paid to The Company, undertakes to insure the under-mentioned goods in transportation subject to the condition of this Policy as per the Clauses printed overleaf and other special clauses attached hereon.

保险货物项目 Description of Goods	包装、单位、数量 Packaging Unit Quantity	保险金额 Amount Insured

--	--	--

承保险别

货物标记

Condition

Marks of Goods

总保险金额:

Total Amount Insured

保费

运输工具

开航日

期:

Premium

As arranged

Per conveyance S.S

Slg. On or abt

启运港

目的港

From

To

所保货物,如发生本保险合同单项下可能引起索赔的损失或损坏,应立即通知本公司下述代理人查勘,如有索赔,应向本公司提交保险单正本(本保险单共有 份正本)及有关文件。如一份正本已用于索赔,其余正本则自动失效。

In the event of loss or damage which may result in a claim under this Policy, immediate notice must be given to the Company's Agent as mentioned hereunder. Claims, if any, one of the Original Policy which has been issued in Original(s) together with the relevant documents shall be surrendered to the Company, if one of the Original Policy has been accomplished, the others to be void.

中保财产保险有限公司

The People's Insurance (Property) Company of China Ltd.

赔款偿付地点

Claim payable at

日期

Date

General Manager: 丁宁

地址:

Address:

4、请根据以上资料缮制 D/P 项下的汇票。(本题共 10 分)
(注:合同的信息必须是修正后的正确信息)

BILL OF EXCHANGE

Drawn under _____

L/C No. _____

Dated _____

No. _____ Exchange for _____

Changsha, China. _____ D/P At _____ sight of this
FIRST of Exchange (Second of exchange being unpaid)

Pay to the order of _____

The sum of _____

To _____

HUNAN HAILI CHEMICAL INDUSTRY CO., LTD.

湖南海利化工有限公司

李灿明

.....
(Authorized Signature)

(2) 实施条件

项目	基本实施条件	备注
场地	每个商务英语实训室配置 40 个操作台面和座位，每个实训室照明通风良好。	必备
设备	每个商务英语实训室配有 1 台服务器、40—50 台计算机，并安装 Office 办公软件，配置局域网。	必备
测评专家	每 40 名考生配备 1 名考评员。考评员要求具备至少二年以上从事国际贸易工作经验或二年以上外贸单证缮制实践教学指导经历。	必备

(3) 考核时量

考核时间 90 分钟。

(4) 评分标准

模块总分	评价内容	配分		考核点	备注	
岗位核心技能模块项目二：外贸单证缮制 (总分 100 分，占总评分的 50%)	职业素养与操作规范 (10 分)	职业素养 (6 分)	2 分	(1) 具备外贸从业人员基本素质，认真严谨、耐心细致、恪守信誉、实事求是、服从安排，听从指挥、举止文明；	在考试过程中不服从安排、举止不得当者，记 0 分。	
			2 分	具备对外贸合同及信用证信息甄别正误及修正能力、正确缮制单证能力，做到数据计算准确、信息填写正确、单据填写完整；	与所述能力及素养不符，扣 1-2 分。	
			2 分	(3) 具备正确规范操作外贸电商平台能力，具有对外贸产品筛选关键信息的能力，符合外贸行业对外贸电商运营等相关岗位需求。	与所述能力及素养不符，扣 1-2 分。	
		操作规范 (4 分)	2 分	(1) 具备使用办公设备和 Office 办公软件的能力，在考核过程中以及考核结束后，不私自更换电脑、不随意关闭或重启电脑，没征求监考老师同意不随意提前或推迟交卷；	若私自更换电脑、随意关闭或重启电脑，记 0 分。	
			2 分	(2) 能严格遵守企业 6S 管理要求（整理、整顿、清扫、清洁、素养、安全）。	若未遵守企业 6S 管理要求，记 0 分。	
		作品 (90 分)	合同审核 (16 分)	2 分	(1) 买卖双方的名称与地址是否有误；	合同审核共 12 个考核点，有 8 处错误，每处 2 分，找出错误计 1 分，修正错误计 1 分。
				2 分	(2) 品名、规格、数量、重量、单价是否有误；	
				2 分	(3) 货物包装、体积是否有误；	
	2 分			(4) 使用的贸易术语是否有误；		
	2 分			(5) 合同金额和币种是否有误；		
	2 分			(6) 合同中溢短装条款是否有误；		
	2 分	(7) 唛头是否有误；				
	2 分	(8) 起运港和目的港是否有误；				
	2 分	(9) 分批装运和转运是否有误；				
2 分	(10) 保险险别、保险金额是否有误；					

			2分	(11) 最迟装运期是否有误;	
			2分	(12) 汇票的付款期限是否有误。	
		商业发票 缮制 (34分)	2分	(1) 进口商名称和地址: 拼写准确无误;	商业发票缮制 部分共 17 个 考核点, 每处 计 2 分, 未填、 错填每处扣 2 分。拼写错误 每 3 处扣 1 分。
			2分	(2) 商业发票号码: 填写准确无误;	
			2分	(3) 商业发票开立日期: 填写准确无误;	
			2分	(4) 合同号码: 填写准确无误;	
			2分	(5) 信用证号码: 填写准确无误;	
			2分	(6) 信用证日期: 填写准确无误;	
			2分	(7) 运输路线装运地: 填写准确无误;	
			2分	(8) 运输路线目的地: 填写准确无误;	
			2分	(9) 价格术语: 填写准确无误;	
			2分	(10) 货物唛头: 填写准确无误;	
			2分	(11) 货物描述: 品名拼写正确, 规格信息 填写准确无误;	
			2分	(12) 货物数量: 填写准确无误;	
			2分	(13) 货物单价及单位: 填写准确无误;	
			2分	(14) 货物金额: 填写准确无误;	
			2分	(15) 货物数量总计: 计算准确无误;	
			2分	(16) 货物金额总计: 计算准确无误, 货币 名称正确;	
			2分	(17) 总金额大写: 英文拼写正确。	
		保险单 缮制 (30分)	2分	(1) 发票号码: 填写准确无误;	保险单缮制部 分共 15 个考 核点, 每处计 2 分, 未填、 错填每处扣 2
			2分	(2) 保险单号次: 填写准确无误;	
			2分	(3) 被保险人公司名称和地址: 填写准确 无误;	

			2分	(4) 被保险货物名称: 填写准确无误;	分。拼写错误每3处扣1分。		
			2分	(5) 外包装的数量和单位: 填写准确无误;			
			2分	(6) 保险金额阿拉伯数字小写: 计算准确无误, 填写正确;			
			2分	(7) 承保险别条款: 填写准确无误, 拼写正确;			
			2分	(8) 货物唛头: 填写准确无误;			
			2分	(9) 保险金额英文大写: 计算准确无误, 拼写正确;			
			2分	(10) 船名和航次: 填写准确无误;			
			2分	(11) 开航日期即提单日期: 填写准确无误;			
			2分	(12) 装运港: 填写准确无误;			
			2分	(13) 目的港: 填写准确无误;			
			2分	(14) 赔款偿付地点及币种: 填写准确无误;			
			2分	(15) 投保日期及地点: 填写准确无误。			
			汇票缮制 (10分)	1分		(1) 出票条款: 开证行完整名称, 拼写准确无误;	汇票缮制部分共10个考核点, 每处计1分, 未填、错填每处扣1分。拼写错误每3处扣1分。
				1分		(2) 信用证号码: 填写准确无误;	
				1分		(3) 信用证开证日期: 填写准确无误;	
1分	(4) 汇票号码: 填写准确无误;						
1分	(5) 汇票日期: 填写准确无误;						
1分	(6) 汇票金额小写: 填写准确无误;						
1分	(7) 汇款期限: 填写准确无误;						
1分	(8) 受款人: 信用证下以议付行为受款人, 托收汇票下以托收行(出口地银行)为受款						

				人：信息完整无误，拼写正确；	
			1分	(9) 金额及币种大写：币种与金额必须与信用证保持一致，拼写准确无误；	
			1分	(10) 付款人：信用证项下付款人为开证行或指定银行：信息完整无误，拼写正确。	

19. 试题编号：2-2-19 合同审核、单证缮制

(1) 任务描述

任务 1：合同审核

读懂谈判备忘录的内容；读懂并审核合同各条款；修改合同中的问题条款。

注意：考试资料中的合同为错误的合同，考试中涉及到合同的信息必须参考修改正确的合同的信息，否则造成的制单错误将不计分。

任务 2：商业发票缮制

分析合同中涉及商业发票缮制的相关条款；准确缮制商业发票；确保缮制的商业发票与合同的条款一致。

任务 3：保险单缮制

分析信用证的保险条款；准确缮制保险单；确保缮制的保险单与信用证的条款一致。

任务 4：汇票缮制

分析合同中涉及汇票缮制的相关条款；准确缮制汇票；确保缮制的汇票与合同的条款一致。

背景资料

1、出口方基本情况

Company	SANY GROUP
Url	http://www.sanygroup.com/group/en-us/
Office Address	SANY INDUSTRY TOWN, ECONOMIC AND TECHNOLOGICAL DEVELOPMENT ZONE, CHANGSHA, HUNAN, CHINA
Zip code	410100
Phone	0086-21-20271802
Fax	0086-21-20271861
E-mail	crd@sany.com.cn

2、进口方基本情况

Company	MERCO TRADING CO.
Url	http://www.mhw-intl.com/about.htm
Office Address	9-11 HARVARD WAY, CANNING VALE 6155, WESTERN AUSTRALIA, AUSTRALIA
Tollfree	无
Phone	(08) 9455 5100
Fax	(08) 9455 5105

3、谈判备忘录

Minutes of a Meeting	
TIME:	May 5-8, 2022
PLACE:	Conference Room of Hunan Hotel, Changsha, Hunan, China
PURPOSE:	To come to an agreement over the transaction of the interested products.
PRESIDING:	Mrs. Wangli (Party A: Sales Manager of Sany Group)
PRESENT:	Mr. Richard Guy (Party B: Purchasing Manager of Merco Trading Co.)

SUMMARY OF THE MEETING

After several rounds of negotiation, Party A and Party B come to terms on May 8 over the transaction of 6,500 pieces of Pipe for Engine. A brief summary of the meeting is as follows:

1. Name of commodity and specifications:

Pipe for Engine

R130 (UP PIPE)

R200 (DOWN PIPE)

R220 (UP PIPE)

2. Packing: packed in cartons of 50 pieces each.

3. Weight and measurement:

G.W.: 10 KGS/CARTON

N.W.: 9 KGS/CARTON

MEAS: 0.02 CBM/CARTON

4. Shipping marks: MERCO

SY80984

NO. 1-130

5. Unit price and quantity: CIF MELBOURNE

R130 (UP PIPE)	USD 3.00/PC	2,000 PIECES
----------------	-------------	--------------

R200 (DOWN PIPE)	USD 4.00/PC	3,000 PIECES
------------------	-------------	--------------

R220 (UP PIPE)	USD 2.00/PC	1,500 PIECES
----------------	-------------	--------------

6. Time and terms of shipment:

To be shipped within 45 days after the contract is signed. Transshipment and partial shipment are not allowed.

7. Ports of loading and destination: From Shanghai to Melbourne

8. Insurance: To be covered against All risks

9. Terms of payment: D/P at sight 10. Documents:

- Commercial Invoice in triplicate.

- Packing List in triplicate.

- Full set of clean on board ocean bills of lading, made out to order of shipper and blank endorsed and marked "freight

prepaid' and notify the buyer.

- Shipping advice must be sent to buyer on the date of shipment advising shipping marks, commodity name, carton numbers, total gross weight, vessel name, bill of lading No., port of loading, destination, contract No. and invoice No. -

Certificate of Origin in duplicate.

- Insurance policy/certificate blank endorsed covering all risks for 110% of the total invoice value.

4、合同

销售合同

SALES CONTRACT

SELLER: SANY GROUP
SANY INDUSTRY TOWN, ECONOMIC AND TECHNOLOGICAL DEVELOPMENT ZONE, CHANGSHA, HUNAN, CHINA
BUYER: MERCO TRADING CO.
9-11 HARVARD WAY, CANNING VALE 6155, WESTERN AUSTRALIA, AUSTRALIA

NO.: SY80984
DATE: MAY 08, 2022
SIGNED IN: CHANGSHA

This contract is made by and agreed between the BUYER and SELLER, in accordance with the terms and conditions stipulated below.

1. Commodity & Specification	2. Quantity	3. Unit Price & Trade Terms	4. Amount
CIF MELBOURNE			
PIPE FOR ENGINE R130 (UP PIPE)	2,000PCS	USD 5.00/PC	USD6,000.00
R200 (DOWN PIPE)	3,000PCS	USD 4.00/PC	USD12,000.00
R220 (UP PIPE)	1,500PCS	USD 2.00/PC	USD 3,000.00
Total:	6,000 PCS		USD 21,000.00

5. Total Value SAY U.S. DOLLARS TWENTY ONE THOUSAND ONLY.

6. Packing PACKED IN CARTON 40 PCS/CARTON
MERCOR

7. Shipping Marks SY80984
NO.1-130

8. Time of Shipment & means of Transportation TO BE EFFECTED BEFORE JUNE 22, 2022 FROM SHANGHAI TO MELBOURNE WITH PARTIAL SHIPMENT ALLOWED AND TRANSSHIPMENT NOT ALLOWED.

9. Port of Loading & Destination FROM: SHENZHEN
TO: MELBOURNE

10. Insurance THE SELLER SHALL COVER INSURANCE AGAINST ALL RISKS AND WAR RISK FOR 110% OF THE TOTAL INVOICE VALUE AS PER THE RELEVANT OCEAN MARINE CARGO

OF P.I.C.C. DATED 1/1/1981

11. Terms of Payment

TO BE MADE BY T/T

12. Remarks

The Buyer

The Seller

MERCO TRADING CO.
(signature)

SANY GROUP
(signature)

5、相关资料

(1) INVOICE NO.: SY99658

(2) INVOICE DATE: JUNE 05, 2022

(3) PACKING:

G. W.(KGS/CTN)	N. W.(KGS/CTN)	MEAS (CBM/CTN)
10	9	0.02

PACKED IN ONE CTN OF 50 PIECES TOTAL ONE 20' CONTAINER

(4) VESSEL: PEACE V. 0107

(5) B/L NO.: COCS000582

(6) B/L DATE: JUNE 20, 2022

(7) POLICY NO.: SH048852

(8) CERTIFICATE NO.: SY20100615

(9) H.S. CODE: 7306900010

(10) COLLECTING BANK: BANK OF CHINA, HUNAN BRANCH

抽考试题

1、请根据考试资料中的谈判备忘录 3 审核错误的合同 4，指出不符之处并修正。

(本题共 16 分)

1. _____
2. _____
3. _____
4. _____

5. _____
6. _____
7. _____
8. _____

2、请根据以上资料缮制商业发票。（本题共 34 分）

（注：合同的信息必须是修正后的正确信息）

三一重工

Sany Group

Sany Industry Town, Economic and Technological Development Zone, Changsha,
Hunan, China

TEL: 0086-21-20271802 FAX: 0086-21-20271861

商业发票

COMMERCIAL INVOICE

TO:		INVOICE NO.:		
		INVOICE DATE:		
		S/C NO.:		
		S/C DATE:		
FROM:		TO:		
Marks and Numbers	Description of Goods	Quantity	Unit Price	Amount
Total:				
<p>SAY TOTAL :</p> <div style="text-align: right; margin-top: 20px;"> <p>SANY GROUP</p> <p>三一重工</p> <p>何浩波</p> <p>-----</p> <p>(Authorized Signature)</p> </div>				

- 3、请根据以上资料缮制保险单。（本题共 30 分）
（注：合同的信息必须是修正后的正确信息）

中保财产保险有限公司

The People's Insurance (Property) Company of China Ltd.

发票号码

保险单号次

Invoice No.

Policy No.

海洋货物运输保险单

MARINE CARGO TRANSPORTATION INSURANCE POLICY

被保险人

Insured:

中保财产保险有限公司（以下简称本公司）根据被保险人的要求，及其所缴付约定的保险费，按照本保险单承担的险别和背面所载条款与下列特别条款承保下列货物运输保险，特签发本保单。

This policy of Insurance witnesses that The People's Insurance (Property) Company of China, Ltd. (hereinafter called "The company"), at the request of the Insured and consideration of the premium paid to The Company, undertakes to insure the under-mentioned goods in transportation subject to the condition of this Policy as per the Clauses printed overleaf and other special clauses attached hereon.

保险货物项目 Description of Goods	包装、单位、数量 Parking Unit Quantity	保险金额 Amount Insured

承保险别

货物标记

Condition

Marks of Goods

总保险金额：

Total Amount Insured

保费

运输工具

开航日期：

Premium As arranged **Per conveyance S.S** **Slg. On or abt**
 启运港 目的港

From **To**

所保货物，如发生本保险合同单项下可能引起索赔的损失或损坏，应立即通知本公司下述代理人查勘，如有索赔，应向本公司提交保险单正本（本保险单共有份正本）及有关文件。如一份正本已用于索赔，其余正本则自动失效。

In the event of loss or damage which may result in a claim under this Policy, immediate notice must be given to the Company's Agent as mentioned hereunder. Claims, if any, one of the Original Policy which has been issued in Original(s) together with the relevant documents shall be surrendered to the Company, if one of the Original Policy has been accomplished, the others to be void.

中保财产保险有限公司
 The People's Insurance (Property) Company of China
 Ltd.

赔款偿付地点

Claim payable at

日期

Date **General Manager:** 丁宁

地址:

Address:

4、请根据以上资料缮制 D/P 项下的汇票。（本题共 10 分）
 （注：合同的信息必须是修正后的正确信息）

BILL OF EXCHANGE

Drawn under _____

L/C No. _____

Dated _____

No. _____ **Exchange for** _____

Changsha, China. _____ **D/P At** _____ **sight of this FIRST**
of Exchange (Second of exchange being unpaid)

Pay to the order of _____

The sum of _____

To _____

SANY GROUP

三一重工

何浩然

(Authorized Signature)

(2) 实施条件

项目	基本实施条件	备注
场地	每个商务英语实训室配置 40 个操作台面和座位，每个实训室照明通风良好。	必备
设备	每个商务英语实训室配有 1 台服务器、40—50 台计算机，并安装 Office 办公软件，配置局域网。	必备
测评专家	每 40 名考生配备 1 名考评员。考评员要求具备至少二年以上从事国际贸易工作经验或二年以上外贸单证缮制实践教学指导经历。	必备

(3) 考核时量

考核时间 90 分钟。

(4) 评分标准

模块总分	评价内容	配分		考核点	备注
岗位核心 技能模块项目二： 外贸单证 缮制 (总分 100)	职业素养 与 操作规范 (10 分)	职业素养 (6 分)	2 分	(1) 具备外贸从业人员基本素质，认真严谨、耐心细致、恪守信誉、实事求是、服从安排，听从指挥、举止文明；	在考试过程中不服从安排、举止不得当者，记 0 分。
			2 分	具备对外贸合同及信用证信息甄别正误及修正能力、正确缮制单证能力，做到数据计算准确、信息填写正确、单据填写完整；	与所述能力及素养不符，扣 1-2 分。

分，占总评分的 50%)		2分	(3)具备正确规范操作外贸电商平台能力，具有对外贸产品筛选关键信息的能力，符合外贸行业对外贸电商运营等相关岗位需求。	与所述能力及素养不符，扣 1-2 分。	
		操作规范 (4分)	2分	(1)具备使用办公设备和 Office 办公软件的能力，在考核过程中以及考核结束后，不私自更换电脑、不随意关闭或重启电脑，没征求监考老师同意不随意提前或推迟交卷；	若私自更换电脑、随意关闭或重启电脑，记 0 分。
			2分	(2)能严格遵守企业 6S 管理要求（整理、整顿、清扫、清洁、素养、安全）。	若未遵守企业 6S 管理要求，记 0 分。
	作品 (90分)	合同审核 (16分)	2分	(1)买卖双方的名称与地址是否有误；	合同审核共 12 个考核点，有 8 处错误，每处 2 分，找出错误计 1 分，修正错误计 1 分。
			2分	(2)品名、规格、数量、重量、单价是否有误；	
			2分	(3)货物包装、体积是否有误；	
			2分	(4)使用的贸易术语是否有误；	
			2分	(5)合同金额和币种是否有误；	
			2分	(6)合同中溢短装条款是否有误；	
			2分	(7)唛头是否有误；	
			2分	(8)起运港和目的港是否有误；	
			2分	(9)分批装运和转运是否有误；	
			2分	(10)保险险别、保险金额是否有误；	
			2分	(11)最迟装运期是否有误；	
			2分	(12)汇票的付款期限是否有误。	
商业发票缮制 (34分)	2分	(1)进口商名称和地址：拼写准确无误；	商业发票缮制部分共 17 个考核点，每处计 2 分，未填、错填每处扣 2		
	2分	(2)商业发票号码：填写准确无误；			
	2分	(3)商业发票开立日期：填写准确无误；			
	2分	(4)合同号码：填写准确无误；			

			2分	(5) 信用证号码: 填写准确无误;	分。拼写错误每3处扣1分。
			2分	(6) 信用证日期: 填写准确无误;	
			2分	(7) 运输路线装运地: 填写准确无误;	
			2分	(8) 运输路线目的地: 填写准确无误;	
			2分	(9) 价格术语: 填写准确无误;	
			2分	(10) 货物唛头: 填写准确无误;	
			2分	(11) 货物描述: 品名拼写正确, 规格信息填写准确无误;	
			2分	(12) 货物数量: 填写准确无误;	
			2分	(13) 货物单价及单位: 填写准确无误;	
			2分	(14) 货物金额: 填写准确无误;	
			2分	(15) 货物数量总计: 计算准确无误;	
			2分	(16) 货物金额总计: 计算准确无误, 货币名称正确;	
			2分	(17) 总金额大写: 英文拼写正确。	
		保险单缮制 (30分)	2分	(1) 发票号码: 填写准确无误;	保险单缮制部分共15个考核点, 每处计2分, 未填、错填每处扣2分。拼写错误每3处扣1分。
			2分	(2) 保险单号次: 填写准确无误;	
			2分	(3) 被保险人公司名称和地址: 填写准确无误;	
			2分	(4) 被保险货物名称: 填写准确无误;	
			2分	(5) 外包装的数量和单位: 填写准确无误;	
			2分	(6) 保险金额阿拉伯数字小写: 计算准确无误, 填写正确;	
			2分	(7) 承保险别条款: 填写准确无误, 拼写正确;	
			2分	(8) 货物唛头: 填写准确无误;	

			2分	(9) 保险金额英文大写: 计算准确无误, 拼写正确;	
			2分	(10) 船名和航次: 填写准确无误;	
			2分	(11) 开航日期即提单日期: 填写准确无误;	
			2分	(12) 装运港: 填写准确无误;	
			2分	(13) 目的港: 填写准确无误;	
			2分	(14) 赔款偿付地点及币种: 填写准确无误;	
			2分	(15) 投保日期及地点: 填写准确无误.	
		汇票缮制 (10分)	1分	(1) 出票条款: 开证行完整名称, 拼写准确无误;	汇票缮制部分 共 10 个考核 点, 每处计 1 分, 未填、错 填 每处扣 1 分。拼写错误 每 3 处扣 1 分。
			1分	(2) 信用证号码: 填写准确无误;	
			1分	(3) 信用证开证日期: 填写准确无误;	
			1分	(4) 汇票号码: 填写准确无误;	
			1分	(5) 汇票日期: 填写准确无误;	
			1分	(6) 汇票金额小写: 填写准确无误;	
			1分	(7) 汇款期限: 填写准确无误;	
			1分	(8) 收款人: 信用证下以议付行为收款人, 托收汇票下以托收行(出口地银行)为收款人: 信息完整无误, 拼写正确;	
			1分	(9) 金额及币种大写: 币种与金额必须与信用证保持一致, 拼写准确无误;	
			1分	(10) 付款人: 信用证项下付款人为开证行或指定银行: 信息完整无误, 拼写正确。	

20. 试题编号：2-2-20 合同审核、单证缮制

(1) 任务描述

任务 1：合同审核

读懂谈判备忘录的内容；读懂并审核合同各条款；修改合同中的问题条款。

注意：考试资料中的合同为错误的合同，考试中涉及到合同的信息必须参考修改正确的合同的信息，否则造成的制单错误将不计分。

任务 2：商业发票缮制

分析合同中涉及商业发票缮制的相关条款；准确缮制商业发票；确保缮制的商业发票与合同的条款一致。

任务 3：保险单缮制

分析信用证的保险条款；准确缮制保险单；确保缮制的保险单与信用证的条款一致。

任务 4：汇票缮制

分析合同中涉及汇票缮制的相关条款；准确缮制汇票；确保缮制的汇票与合同的条款一致。

背景资料

1、出口方基本情况

Company	SANY GROUP
Url	http://www.sanygroup.com/group/en-us/
Office Address	SANY INDUSTRY TOWN, ECONOMIC AND TECHNOLOGICAL DEVELOPMENT ZONE, CHANGSHA, HUNAN, CHINA
Zip code	410100
Phone	0086-21-20271802

Fax	0086-21-20271861
E-mail	crd@sany.com.cn

2、进口方基本情况

Company	THE TOKYO ELECTRIC POWER COMPANY, INCORPORATED (TEPCO)
Url	http://www.tepco.co.jp/en/index-e.html
Office Address	1-1-3 UCHISAIWAI-CHO, CHIYODA-KU, TOKYO, JAPAN
Tollfree	无
Phone	+81-3-6373-1111
Fax	无

3、谈判备忘录

Minutes of a Meeting	
TIME:	Oct. 22-28, 2022
PLACE:	Conference Room of Sheraton Hotel, Changsha, Hunan, China
PURPOSE:	To come to an agreement over the transaction of the interested products.
PRESIDING:	Mrs. Wangli (Party A: Sales Manager of Sany Group)
PRESENT:	Mr. Clark (Party B: Purchasing Manager of The Tokyo Electric Power Company.)
SUMMARY OF THE MEETING	
<p>After several rounds of negotiation, Party A and Party B come to terms on October 28 over the transaction of 10,000 pieces of Malleable Flanged Nipple. A brief summary of the meeting is as follows:</p> <ol style="list-style-type: none"> 1. Name of commodity and specifications: Malleable Flanged Nipple 2. Packing: To be packed in export corrugated paper box. <ul style="list-style-type: none"> Inner box: 3 layers of corrugated paper Carton: 5 layers of corrugated paper Size: 20 mm 100 pieces/carton. 	

3. Weight and measurement:
 G.W.: 4 KGS/CTN
 N.W.: 3.0 KGS/CTN
 MEAS: 0.02 CBM/CTN
4. Shipping marks: TOKYO ELECTRIC POWER
 SY11803
 NO. 1-100
5. Unit price and quantity: USD 2.00/PC CIF OSAKA, 10,000 PCS
6. Time and terms of shipment: To be shipped within 45 days after the contract is signed. Transshipment and partial shipment are not allowed.
7. Ports of loading and destination: From Shanghai to Osaka
8. Insurance: To be covered against All risks and War risk
9. Terms of payment: D/P AT SIGHT
10. Documents:
 - Commercial Invoice in triplicate.
 - Packing List in triplicate.
 - Full set of clean on board ocean bills of lading, made out to order of shipper and blank endorsed and marked "freight prepaid" and notify the buyer.
 - Shipping advices must be sent to buyer on the date of shipment advising shipping marks, commodity name, carton numbers, total gross weight, vessel name, bill of lading No., port of loading, destination, contract No. and invoice No.
 - Certificate of Origin in duplicate.
 - Insurance policy/certificate blank endorsed covering all risks and war risk for 110% of the total invoice value.

4、合同

销售合同

SALES CONTRACT

SELLER:	SANY GROUP.	NO.:	SY11803
	SANY INDUSTRY TOWN, ECONOMIC AND	DATE:	NOV. 2, 2022
	TECHNOLOGICAL DEVELOPMENT ZONE,	SIGNED IN:	CHANGSHA

CHANGSHA, HUNAN, CHINA

BUYER: THE TOKYO ELECTRIC POWER COMPANY, INCORPORATED (TEPCO)
1-1-1 UCHISAIWAI-CHO, CHIYODA-KU, TOKYO, JAPAN

This contract is made by and agreed between the BUYER and SELLER, in accordance with the terms and conditions stipulated below.

1. Commodity & Specification	2. Quantity	3. Unit Price & Trade Terms	4. Amount
CIF OSAKA			
MALLEABLE FLANGED NIPPLE IRON, ISO9001 HOT-DIPPED GALVANIZATION, BLACK ENAMEL 2.20MM,25MM,32MM	10,000 PCS	USD 3.00/PC	USD 20,000.00
Total:	10,000 PCS		USD 20,000,00

5. Total Value SAY U.S. DOLLARS TWENTY ONE THOUSAND ONLY

6. Packing PACKED IN EXPORT CORRUGATED PAPER BOX.
INNER BOX: 3 LAYERS OF CORRUGATED PAPER
CARTON: 5 LAYERS OF CORRUGATED PAPER
SIZE 20MM
100 PIECES/CARTON
TOTAL: 100 CARTONS

7. Shipping Marks TOKYO ELECTRIC POWER SY10808 NO. 1-100

8. Time of Shipment & means of Transportation TO BE EFFECTED BEFORE THE END OF DECEMBER 2022
FROM SHANGHAI TO OSAKA WITH PARTIAL SHIPMENT
AND TRANSSHIPMENT NOT ALLOWED.

14. Port of Loading & Destination FROM: SHENZHEN TO: PUSAN

10. Insurance THE SELLER SHALL COVER INSURANCE AGAINST ALL
RISKS & WAR RISK FOR 120% OF THE TOTAL INVOICE
VALUE AS PER THE RELEVANT OCEAN MARINE CARGO
OF P.I.C.C. DATED 1/1/1981

11. Terms of Payment TO BE MADE BY T/T

12. Remarks

The Buyer.
THE TOKYO ELECTRIC
POWER COMPANY,
INCORPORATED (TEPCO)

The Seller
SANY GROUP

(signature)

(signature)

5、相关资料

(1) INVOICE NO.: SY99685

(2) INVOICE DATE: NOV. 17, 2022

(3) PACKING

G. W.(KGS/BOX)	N. W.(KGS/BOX)	MEAS (CBM/BOX)
4	3.0	0.02

PACKED IN ONE CTN OF 100 PIECES TOTAL ONE 20' CONTAINER

(4) VESSEL: MEIYU V. 0289

(5) B/L NO.: COCS006629

(6) B/L DATE: DEC. 15, 2022

(7) POLICY NO.: TY076859

(8) REFERENCE NO.: 20221125

(9) H.S. CODE: 8413910000

(10) COLLECTING BANK: BANK OF CHINA, HUNAN BRANCH

抽考试题

1、请根据考试资料中的谈判备忘录 3 审核错误的合同 4，指出不符之处并修正。

(本题共 16 分)

1. _____
2. _____
3. _____
4. _____
5. _____
6. _____
7. _____
8. _____

2、请根据以上资料缮制商业发票。（本题共 34 分）

（注：合同的信息必须是修正后的正确信息）

三一重工

Sany Group

Sany Industry Town, Economic and Technological Development Zone, Changsha,

Hunan, China

TEL: 0086-21-20271802 FAX: 0086-21-20271861

商业发票

COMMERCIAL INVOICE

TO:		INVOICE NO.:		
		INVOICE DATE:		
		S/C NO.:		
		S/C DATE:		
FROM:		TO:		
Marks and Numbers	Description of Goods	Quantity	Unit Price	Amount
Total:				

SAY TOTAL :

SANY GROUP

三一重工

何浩斌

(Authorized Signature)

3、请根据以上资料缮制保险单。（本题共 30 分）

（注：合同的信息必须是修正后的正确信息）

中保财产保险有限公司

The People's Insurance (Property) Company of China Ltd.

发票号码

保险单号次

Invoice No.

Policy No.

海 洋 货 物 运 输 保 险 单

MARINE CARGO TRANSPORTATION INSURANCE POLICY

被保险人

Insured:

中保财产保险有限公司（以下简称本公司）根据被保险人的要求，及其所缴付约定的保险费，按照本保险单承担的险别和背面所载条款与下列特别条款承保下列货物运输保险，特签发本保单。

This policy of Insurance witnesses that The People's Insurance (Property) Company of China, Ltd. (hereinafter called "The company"), at the request of the Insured and consideration of the premium paid to The Company, undertakes to insure the under-mentioned goods in transportation subject to the condition of this Policy as per the Clauses printed overleaf and other special clauses attached hereon.

保险货物项目 Description of Goods	包装、单位、数量 Packaging Unit Quantity	保险金额 Amount Insured

承保险别

货物标记

Condition

Marks of Goods

总保险金额：

Total Amount Insured

开航日

保费

运输工具

期：

Per conveyance

Premium

As arranged

S.S

Slg. On or abt

启运港

目的港

From

To

所保货物，如发生本保险合同单项下可能引起索赔的损失或损坏，应立即通知本公司下述代理人查勘，如有索赔，应向本公司提交保险单正本（本保险单共有 份正本）及有关文件。如一份正本已用于索赔，其余正本则自动失效。

In the event of loss or damage which may result in a claim under this Policy, immediate notice must be given to the Company's Agent as mentioned hereunder. Claims, if any, one of the Original Policy which has been issued in Original(s) together with the relevant documents shall be surrendered to the Company, if one of the Original Policy has been accomplished, the others to be void.

中 保 财 产 保 险 有 限 公 司

赔款偿付地点

Claim payable at

日期

Date

**General
Manager:**

丁宁

地址:

Address:

4、请根据以上资料缮制 D/P 项下的汇票。(本题共 10 分)

(注: 合同的信息必须是修正后的正确信息)

BILL OF EXCHANGE

Drawn under _____

L/C No. _____

Dated _____

No. _____ **Exchange for** _____
Changsha, China. _____ **D/P At** _____ **sight of this FIRST of**
Exchange (Second of exchange being unpaid)

Pay to the order of _____

The sum of _____

To _____

SANY GROUP
三一重工
何浩斌

(Authorized Signature)

(2) 实施条件

项目	基本实施条件	备注
场地	每个商务英语实训室配置 40 个操作台面和座位, 每个实训室照明通风良好。	必备

设备	每个商务英语实训室配有 1 台服务器、40—50 台计算机，并安装 Office 办公软件，配置局域网。	必备
测评专家	每 40 名考生配备 1 名考评员。考评员要求具备至少二年以上从事国际贸易工作经验或二年以上外贸单证缮制实践教学指导经历。	必备

(3) 考核时量

考核时间 90 分钟。

(4) 评分标准

模块总分	评价内容	配分		考核点	备注
岗位核心技能模块 项目二： 外贸单证缮制 (总分 100 分，占总评分的 50%)	职业素养与操作规范 (10 分)	职业素养 (6 分)	2 分	(1) 具备外贸从业人员基本素质，认真严谨、耐心细致、恪守信誉、实事求是、服从安排，听从指挥、举止文明；	在考试过程中不服从安排、举止不当者，记 0 分。
			2 分	具备对外贸合同及信用证信息甄别正误及修正能力、正确缮制单证能力，做到数据计算准确、信息填写正确、单据填写完整；	与所述能力及素养不符，扣 1-2 分。
			2 分	(3) 具备正确规范操作外贸电商平台能力，具有对外贸产品筛选关键信息的能力，符合外贸行业对外贸电商运营等相关岗位需求。	与所述能力及素养不符，扣 1-2 分。
		操作规范 (4 分)	2 分	(1) 具备使用办公设备和 Office 办公软件的能力，在考核过程中以及考核结束后，不私自更换电脑、不随意关闭或重启电脑，没征求监考老师同意不随意提前或推迟交卷；	若私自更换电脑、随意关闭或重启电脑，记 0 分。
			2 分	(2) 能严格遵守企业 6S 管理要求（整理、整顿、清扫、清洁、素养、安全）。	若未遵守企业 6S 管理要求，记 0 分。

	作品 (90分)	合同审核 (16分)	2分	(1) 买卖双方的名称与地址是否有误;	合同审核共12个考核点,有8处错误,每处2分,找出错误计1分,修正错误计1分。
			2分	(2) 品名、规格、数量、重量、单价是否有误;	
			2分	(3) 货物包装、体积是否有误;	
			2分	(4) 使用的贸易术语是否有误;	
			2分	(5) 合同金额和币种是否有误;	
			2分	(6) 合同中溢短装条款是否有误;	
			2分	(7) 唛头是否有误;	
			2分	(8) 起运港和目的港是否有误;	
			2分	(9) 分批装运和转运是否有误;	
			2分	(10) 保险险别、保险金额是否有误;	
			2分	(11) 最迟装运期是否有误;	
			2分	(12) 汇票的付款期限是否有误。	
				商业发票 缮制 (34分)	
	2分	(2) 商业发票号码: 填写准确无误;			
	2分	(3) 商业发票开立日期: 填写准确无误;			
	2分	(4) 合同号码: 填写准确无误;			
	2分	(5) 信用证号码: 填写准确无误;			
	2分	(6) 信用证日期: 填写准确无误;			
	2分	(7) 运输路线装运地: 填写准确无误;			
	2分	(8) 运输路线目的地: 填写准确无误;			
	2分	(9) 价格术语: 填写准确无误;			
	2分	(10) 货物唛头: 填写准确无误;			
			2分	(11) 货物描述: 品名拼写正确,规格信息填写准确无误;	
		2分	(12) 货物数量: 填写准确无误;		

			2分	(13) 货物单价及单位: 填写准确无误;	
			2分	(14) 货物金额: 填写准确无误;	
			2分	(15) 货物数量总计: 计算准确无误;	
			2分	(16) 货物金额总计: 计算准确无误, 货币名称正确;	
			2分	(17) 总金额大写: 英文拼写正确。	
		保险单缮制 (30分)	2分	(1) 发票号码: 填写准确无误;	保险单缮制部分共15个考核点, 每处计2分, 未填、错填每处扣2分。拼写错误每3处扣1分。
			2分	(2) 保险单号次: 填写准确无误;	
			2分	(3) 被保险人公司名称和地址: 填写准确无误;	
			2分	(4) 被保险货物名称: 填写准确无误;	
			2分	(5) 外包装的数量和单位: 填写准确无误;	
			2分	(6) 保险金额阿拉伯数字小写: 计算准确无误, 填写正确;	
			2分	(7) 承保险别条款: 填写准确无误, 拼写正确;	
			2分	(8) 货物唛头: 填写准确无误;	
			2分	(9) 保险金额英文大写: 计算准确无误, 拼写正确;	
			2分	(10) 船名和航次: 填写准确无误;	
			2分	(11) 开航日期即提单日期: 填写准确无误;	
			2分	(12) 装运港: 填写准确无误;	
			2分	(13) 目的港: 填写准确无误;	
			2分	(14) 赔款偿付地点及币种: 填写准确无误;	
			2分	(15) 投保日期及地点: 填写准确无误。	

		汇票缮制 (10分)	1分	(1) 出票条款: 开证行完整名称, 拼写准确无误;	汇票缮制部分共 10 个考核点, 每处计 1 分, 未填、错填 每处扣 1 分。拼写错误 每 3 处扣 1 分。
	1分		(2) 信用证号码: 填写准确无误;		
	1分		(3) 信用证开证日期: 填写准确无误;		
	1分		(4) 汇票号码: 填写准确无误;		
	1分		(5) 汇票日期: 填写准确无误;		
	1分		(6) 汇票金额小写: 填写准确无误;		
	1分		(7) 汇款期限: 填写准确无误;		
	1分		(8) 收款人: 信用证下以议付行为收款人, 托收汇票下以托收行(出口地银行)为收款人: 信息完整无误, 拼写正确;		
	1分		(9) 金额及币种大写: 币种与金额必须与信用证保持一致, 拼写准确无误;		
	1分		(10) 付款人: 信用证项下付款人为开证行或指定银行: 信息完整无误, 拼写正确。		

四、跨岗位综合技能模块

1. 试题编号：3-1-1 跨境电商平台综合应用能力

(一) 任务描述

内容：仔细阅读命题，就 B2C 跨境电子商务平台产品推广、产品开发、引流营销、客户服务、平台规则等业务操作环节作答。

要求：从 A、B、C、D，四个选项中选择一个最适合的答案，每题 1 分，多选、错选、漏选，均不得分。

1、“在速卖通平台，卖家将订单链接、运费补差价链接、赠品、定金、新品预告等商品作为特殊商品存在于网站上面，但没有按规定放置到指定的特殊发布类目中。”这属于以下哪种搜索作弊行为？

()

- A. 商品发布类目乱发
- B. 商品标题、关键词滥用
- C. 黑五类商品的乱放
- D. 商品价格与运费倒挂

2、“在速卖通平台，卖家将同一件商品恶意发布为多个商品进行销售。”这属于以下哪种搜索作弊行为？()

- A. 重复铺货骗曝光
- B. 商品标题、关键词滥用
- C. 重复开小账号抢曝光
- D. 商品价格与运费倒挂

3、“在速卖通平台，卖家以超低价格发布商品，同时调高运费价格，吸引买家注意，骗取曝光。”这属于以下哪种搜索作弊行为？()

- A. 重复铺货骗曝光
- B. 商品标题、关键词滥用
- C. 商品销量炒作
- D. 商品价格与运费倒挂

4、速卖通平台中，在热销词的页面，词所在圆圈的大小表示什么含义？()

A. 搜索量 B. 销量 C. 竞争度 D. 关注度

5、速卖通平台中，以下哪项简称代表商品成交总额？（ ）

A. GMV B. UV C. SNS D. PV

6、“搜索引擎营销”的英文缩写是（ ）。

A. SEM B. SNS C. EMS D. MSN

7、判断引号中的文字表述是否正确。（ ）

“在敦煌网平台，如果个人卖家在进行身份认证资料图片的上传过程中提供了虚假资料，那么他的账号将被关闭。”

A. 正确 B. 错误

8、卖家在敦煌网经营了一家店铺，如果仅绑定了A品类商品，那么不能上传以下哪款产品？（ ）

A. 耳机 B. 手机充电器 C. 电视 D. 手表

9、鑫鑫在敦煌网上销售了一款体温计，但她自开店以来并未向平台提供过任何销售许可证书，她的行为构成（ ）。

A. 一般违规 B. 严重违规 C. 一般违法 D. 严重违法

10、“Its compact size and unique design make it easy to transport.”这是某店铺一款沙发的产品描述，请选出句中“compact”的正确解释。（ ）

A. 复杂的 B. 紧凑的 C. 牢固的 D. 精确的

11、亚马逊平台美国站中“BMVD”是指什么的缩写？（ ）

- A. 电子阅读器和书籍
- B. 媒介类商品（图书、音乐、影视）
- C. 音箱和家庭影院
- D. 漫画与绘画小说

12、判断引号中的文字表述是否正确。（ ）

“eBay 专门制定了 ‘VeRO’ (Verified Rights Owner) 计划，只有知识产权所有者才可以举报侵犯了他们版权、商标权或其他知识产权的 eBay 物品刊登。”

A. 正确 B. 错误

13、以下哪张图片符合亚马逊平台主图片的要求？（ ）



14、在 eBay 平台 Best offer 议价功能中，如果卖家收到议价低于设置的下限价格，eBay 会自动发送邮件给买家拒绝此次议价。买家此时可以发送一个稍高价格的议价，卖家也可以进行反向议价。在大部分品类中，买家针对一个产品可以发送几次议价？（ ）

A. 2 B. 3 C. 5 D. 6

15、下列选项中，哪个是“移动电源”的英文翻译？（ ）

A. Mobile Phone Batteries B. Mobile Phone Chargers
C. Battery Charger Cases D. External Battery Pack

16、“Act of failing to fulfill a obligation” 这描述的是以下哪个选项？（ ）

- A. 派送 B. 违约 C. 任务 D. 目标

17、选择合适的选项补全句子。

Our company aims to provide ___ designs with ___ price to young women. ()

- A. trending, afford B. trendy, afford
C. trendy, affordable D. trend (n. 趋势), afford

18、Which of the following sentences convey the meaning of “货物仍在运输途中”？ ()

- A. We have send out your products
B. The order was send to you
C. The package has arrived at your end
D. Your parcel is on the way

19、在 Wish 平台，“物流服务商提供配送商品的全程妥投信息”，这句话是指下列哪个名称？ ()

- A. Wish 邮 B. 全程物流跟踪
C. 最后一公里物流跟踪 D. 物流妥投信息

20、以下哪项不是 eBay 平台中的违禁品和受管制物品？ ()

- A. 手机贴膜 B. 优惠券 C. 彩票 D. 慈善及筹款

(二) 实施条件

项目	基本实施条件	备注
场地	每个商务英语实训室配置 40 个操作台面和座位,每个实训室照明通风良好。	必备
设备	每个商务英语实训室配有 1 台服务器、40—50 台计算机,并安装 Office 办公软件,配置局域网。	必备
测评专家	每 40 名考生配备 1 名考评员。考评员要求具备至	必备

	少二年以上从事跨境电商工作经验或三年以上商务英语实践教学指导经历。	
--	-----------------------------------	--

(三) 考核时量

考试时间：30 分钟

(四) 评分标准

模块总分		评价内容	配分	考核点	备注
跨岗位综合技能 (总分 100 分, 占总评分的 20%)	职业素养与操作规范 (10 分)	职业素养 (6 分)	2 分	(1) 具备跨境电商从业人员基本素质, 认真严谨、耐心细致、恪守信誉、实事求是、服从安排, 听从指挥、举止文明, 记 2 分。	在考试过程中不服从安排、举止不得当者, 记 0 分。
			2 分	(2) 具备跨境电商从业人员良好的翻译素养, 认真严谨, 耐心细致, 记 2 分。	考试过程中出现与所述能力及素养不符, 扣 1-2 分。
			2 分	(3) 具备跨境电商从业人员良好的沟通能力、表达能力和合作意识, 待人真诚礼貌, 记 2 分。	考试过程中出现与所述能力及素养不符, 扣 1-2 分。
		操作规范 (4 分)	2 分	(1) 具备使用办公设备和 Office 办公软件的能力, 在考核过程中以及考核结束后, 不私自更换电脑、不随意关闭或重启电脑, 没征求监考老师同意不随意提前或推迟交卷, 记 2 分。	若私自更换电脑、随意关闭或重启电脑, 记 0 分。
	2 分		(2) 能严格遵守企业 6S 管理要求 (整理、整顿、清扫、清洁、素养、安全), 记 2 分。	若未遵守企业 6S 管理要求, 记 0 分。	
		任务 (90 分)		18 分	B2C 跨境电子商务平台产品推广等业务操作环节作答。

			18分	B2C 跨境电子商务平台产品开发等业务操作环节作答。	从四个选项选择一个最适合的答案，每题 4.5 分，多选、错选、漏选，均不得分。
			18分	B2C 跨境电子商务平台引流营销等业务操作环节作答。	从四个选项选择一个最适合的答案，每题 4.5 分，多选、错选、漏选，均不得分。
			18分	B2C 跨境电子商务平台客户服务等业务操作环节作答。	从四个选项选择一个最适合的答案，每题 4.5 分，多选、错选、漏选，均不得分。
			18分	B2C 跨境电子商务平台规则等业务操作环节作答。	从四个选项选择一个最适合的答案，每题 4.5 分，多选、错选、漏选，均不得分。

2. 试题编号：3-1-2 跨境电商平台综合应用能力

(一) 任务描述

内容：仔细阅读命题，就 B2C 跨境电子商务平台产品推广、产品开发、引流营销、客户服务、平台规则等业务操作环节作答。

要求：从 A、B、C、D，四个选项中选择一个最适合的答案，每题 1 分，多选、错选、漏选，均不得分。

1. 在速卖通平台上，一个专卖店可以申请的品牌数量有多少个？

()

- A. 仅 1 个 B. 必须两个以上 C. 两个 D. 可多个

2. 下列三张手绘衣服图分别属于什么领型, 请选择与衣服图片匹配正确的领型选项。()

A. V-neck、Turn-down collar、Stand collar

B. Turn-down collar、V-neck、Stand collar

C. V-neck、Stand collar、Turn-down collar

D. Stand collar、Turn-down collar、V-neck



3. O2O是()的缩写。

A. online to online

B. online to offline

C. offline to offline

D. offline to online

4. 以下物流方式属于邮政物流的是()。

A. ePacket

B. TOLL

C. UPS

D. SF

5. 根据速卖通知识产权规则, 对于著作权一般侵权行为, 首次违规扣0分, 其后每次重复违规扣()分

A. 3

B. 6

C. 8

D. 12

6. 下方为4张不同类型的女式衣服袖型图, 其中蝙蝠袖和盖肩袖的衣服分别为哪两张图?()



- A. 图 A 和图 B B. 图 B 和图 C
C. 图 C 和图 D D. 图 B 和图 D

7. “An online auction and shopping website in which people and businesses buy and sell a wide variety of goods and services worldwide. It was founded by Pierre Omidyar in 1995, and became a notable success story of the dot-com bubble.” 这描述的是以下哪个电商平台？（ ）

- A. Amazon B. EBay
C. Wish D. AliExpress

8. 速卖通的卖家频道网址是下列中的哪一个？（ ）

- A. daxue.aliexpress.com B. www.alibaba.com
C. www.aliexpress.com D. seller.aliexpress.com

9. UV——Unique _____，是指通过互联网访问、浏览这个网页的自然人。访问这个网站的一台电脑客户端为一个访客。请选择横线上的单词。（ ）

- A. Volume B. Visitor C. Valuate D. Vacuum

10. 跨境电商中专业术语“每点击成本”的英文缩（ ）

- A. CPA B. CPM C. CPC D. CPR

11. 关于“eBay 供需分析”的数据更新时间表述正确的是（ ）

- A. 每小时更 B. 每日更新 C. 每周更新 D. 每月更新

12. 速卖通平台中，以下哪项简称代表销售总额？（ ）
A. GMV B. UV C. SNS D. PV
13. 下列哪一项产品类别不属于速卖通平台禁止销售的？（ ）
A. 毒品类 B. 枪支弹药类
C. 医疗器械类 D. 品牌箱包类
14. 下列哪件商品可以在亚马逊平台美国站上销售？（ ）
A. 手机壳 B. 名贵烟丝
C. 象牙刀柄 D. 银行票据
15. 速卖通服饰行业标准规定：商品标题关键字使用“羽绒”，商品必须满足的含绒量不得低于（ ）？
A. 30% B. 40% C. 50% D. 60%
16. 参考中文描述，选择一个合适的选项使英文句子表述完整。
“第 12583 号合同项下的货物完好无损。”
“The goods under Contract No. 12583 left here _____. ”（ ）
A. in a good condition B. in good condition
C. in good conditions D. in the good condition
17. 请选择合适的选项将句子补充完整。It's obvious your package is not _____, so I'm sure the damage was not due to careless handling during transit.（ ）
A. reinforced B. revealed
C. referenced D. recommend
18. 敦煌网是国内领先的专业跨境电子商务平台，它成立于（ ）年。
A. 2001 B. 2004 C. 2009 D. 2010
19. 以下关于速卖通账户注册的说法，错误的是（ ）

A. 速卖通平台，一个电子邮箱仅能注册一个可出售商品的速卖通账户（主账户）

B. 注册时需要完成邮箱验证和手机验证

C. 经过平台批准，可以出租、出借或转让账号

D. 若在经营期间由于“服务指标”考核不达标被清退或中途退出经营大类，在同一年度内将无法再次申请加入该经营大类

20. 请仔细阅读英文语句，并选择合适的选项补全该句：G-mart Wireless Sport Headphone with mic and Bluetooth 4.1, made () Cellphones as Samsung.

A. for

B. by

C. on

D. with

（二）实施条件

项目	基本实施条件	备注
场地	每个商务英语实训室配置 40 个操作台面和座位，每个实训室照明通风良好。	必备
设备	每个商务英语实训室配有 1 台服务器、40—50 台计算机，并安装 Office 办公软件，配置局域网。	必备
测评专家	每 40 名考生配备 1 名考评员。考评员要求具备至少二年以上从事跨境电商工作经验或三年以上商务英语实践教学指导经历。	必备

（三）考核时量

考试时间：30 分钟

（四）评分标准

模块总分	评价内容	配分	考核点	备注
------	------	----	-----	----

跨岗位综合技能（总分100分，占总评分的20%）	职业素养与操作规范（10分）	职业素养（6分）	2分	（1）具备跨境电商从业人员基本素质，认真严谨、耐心细致、恪守信誉、实事求是、服从安排，听从指挥、举止文明，记2分。	在考试过程中不服从安排、举止不得当者，记0分。
			2分	（2）具备跨境电商从业人员良好的翻译素养，认真严谨，耐心细致，记2分。	考试过程中出现与所述能力及素养不符，扣1-2分。
			2分	（3）具备跨境电商从业人员良好的沟通能力、表达能力和合作意识，待人真诚礼貌，记2分。	考试过程中出现与所述能力及素养不符，扣1-2分。
		操作规范（4分）	2分	（1）具备使用办公设备和 Office 办公软件的能力，在考核过程中以及考核结束后，不私自更换电脑、不随意关闭或重启电脑，没征求监考老师同意不随意提前或推迟交卷，记2分。	若私自更换电脑、随意关闭或重启电脑，记0分。
			2分	（2）能严格遵守企业 6S 管理要求（整理、整顿、清扫、清洁、素养、安全），记2分。	若未遵守企业 6S 管理要求，记0分。
		任务（90分）		18分	B2C 跨境电子商务平台产品推广等业务操作环节作答。
	18分			B2C 跨境电子商务平台产品开发等业务操作环节作答。	从四个选项中选择最适合的答案，每题 4.5 分，多选、错选、漏选，均不得分。
	18分			B2C 跨境电子商务平台引流营销等业务操作环节作答。	从四个选项中选择最适合的答案，每题 4.5 分，多选、错选、漏选，均不得分。
	18分			B2C 跨境电子商务平台客户服务等业务操作环节作答。	从四个选项中选择最适合的答案，每题 4.5 分，多选、错选、漏选，均不得分。

			18分	B2C 跨境电子商务平台规则等业务操作环节作答。	从四个选项中选择一个最适合的答案，每题 4.5 分，多选、错选、漏选，均不得分。
--	--	--	-----	--------------------------	--

3. 试题编号：3-1-3 跨境电商平台综合应用能力

(一) 任务描述

内容：仔细阅读命题，就 B2C 跨境电子商务平台产品推广、产品开发、引流营销、客户服务、平台规则等业务操作环节作答。

要求：从 A、B、C、D，四个选项中选择一个最适合的答案，每题 1 分，多选、错选、漏选，均不得分。

1. 以下是跨境电商行业中常见的英文术语，选项中与之匹配的中文解释全部正确的是（ ）。

- | | |
|--------------------------|----------|
| ①target audience | a. 目标用户 |
| ②invalid tracking number | b. 上架价格 |
| ③sales promotions | c. 中间手续费 |
| ④flash sale | d. 产品促销 |
| ⑤list price | e. 限时折扣 |
| ⑥deals expire | f. 库存 |
| ⑦inventory | g. 有效期 |
| ⑧brokerage fees | h. 无效运单号 |

2. 在速卖通平台，某件连衣裙的标题为“Women Dress Fashion Casual Women Dress Vintage Printing Dress Sleeveless Halter Evening Party Prom Swing Dress”，请问这件商品违反了以下哪个搜索作弊

行为？（ ）

- A. 标题堆砌
- B. 黑五类产品错放
- C. 重复铺货
- D. 描述不符

3. 在 eBay 平台，SKU 供需关系分析中，气泡大小代表该 SKU 的销售量，下列说法正确是？（ ）

- A. 气泡越小代表当前销售量越大
- B. 气泡越大代表当前销售量越大
- C. 气泡越大代表当前销售量越小
- D. 气泡越小代表当前销售量饱和

4. 下列四种收款方式中，哪个是 Wish 平台官方支持的？（ ）

- A. Tenpay
- B. Alipay
- C. Payoneer
- D. Weibo

5. 下图为速卖通某店铺的商品页面，据图判断，该店铺在发布此项商品时有何种搜索作弊行为？（ ）

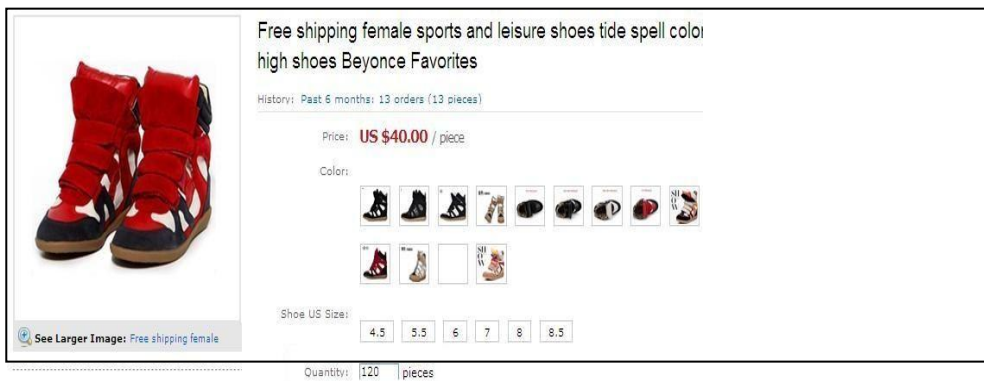

- A. 黑五类商品错放
- B. 描述不符
- C. 计量单位作弊
- D. 运费不符

6. 跨境电商的“三流”指的是。（ ）

- A. 信息流，物流，资金流
- B. 信息流，产品流，物流
- C. 产品流，技术流，资金流
- D. 信息流，产品流，技术流

7. 以下关于 eBay 平台“标题制作”说法不正确的是（ ）
- A. 用尽 80 个字符，标题尽量详细。
 - B. 将重要的关键字写在标题的前面。
 - C. 在标题中添加重复信息或多个同义词会导致买家难以阅读，例如，“ipad I pad 32gb 32 gb”
 - D. 全部使用大写字母
8. 根据速卖通平台规则，所谓“两高一低”品牌是指（ ）
- A. 高销量、高价格，低纠纷的商品品牌
 - B. 高销量、高价格，低投诉的商品品牌
 - C. 高纠纷、高投诉，低市场认可度的商品品牌
 - D. 高成本、高纠纷，低利润的商品品牌
9. 附件中的产品在速卖通平台中所属类目为（ ）。
- A. smart watches B. Dresses
 - C. Laptops D. Jewelry



10. 请仔细阅读英文语句，并选择合适的选项补全该句：G-mart Wireless Sport Headphone with mic and Bluetooth 4.1, made () Cellphones as Samsung.
- A. for B. by C. on D. with

11. 阿里巴巴国际站针对卖家知识产权严重侵权行为采取记振处罚方式，根据处罚标准，若卖家严重侵权行为累积被记振三次将会面临怎样的处罚？（ ）

- A. 限权 7 天+考试（若考试未在 7 天内通过最长限权 30 天）
- B. 限权 14 天+考试（若考试未在 14 天内通过最长限权 60 天）
- C. 限权 21 天+考试（若考试未在 21 天内通过最长限权 60 天）
- D. 关闭账号

12. “搜索引擎营销”的英文缩写是（ ）。

- A. SEM
- B. SNS
- C. EMS
- D. MSN

13. “在速卖通平台，卖家将同一件商品恶意发布为多个商品进行销售。”这属于以下哪种搜索作弊行为？（ ）

- A. 重复铺货骗曝光
- B. 商品标题、关键词滥用
- C. 重复开小账号抢曝光
- D. 商品价格与运费倒挂

14. 请仔细阅读下面邮件，并选择邮件所表达的内容。（ ）

Dear Ethem,

Thank you for your patience. We confirm that your order was sent (Order No: 88756668845) on May 20th. However, the tracking detail shows that it's still on the way. We were informed that the package did not arrive yet due to a shipping delay from the delivery company. If you do not receive your package before May 27th, we can resend your order or apply a full refund to you as per your choice. If you have any further questions, please feel free to contact us directly and we will be glad to help you.

Best Regards,

Calic

- A. 给买家推荐更多相关产品
- B. 同意客户退款请求
- C. 回复客户关于预期内未收到货的问题
- D. 提醒买家收货后给好评

15. Latest Bluetooth 4.1 CSR technology and state of the art acoustic components (元件) that produce incredible sound quality with deep bass and crystal clear treble. 这段英文描述最有可能是以下哪个选项的产品卖点? ()

- A. earphone B. jewelry
- C. artwork D. washing machine

16. 在 Wish 平台诚信店铺的考核指标中,有效跟踪率和延迟发货率每隔多久更新一次? ()

- A. 每 1 小时 B. 每 8 小时 C. 每天 D. 每周

17. 判断引号中的文字表述是否正确。 ()

“在速卖通平台,知识产权严重侵权案件只有一次申诉机会,申诉不成功将可能被直接关闭账号。”

- A. 正确 B. 错误

18. 在客户关系管理中,RFM 模型分类方法是被广泛运用的,也是非常直观简捷的工具,那么其中的“R”指什么? ()

- A. 消费频率,即在单位时间内的消费次数
- B. 最近的一次消费,客户上一次在店铺成交的时间和成交的产品
- C. 消费金额,单位期间内的消费总额
- D. 产品属性,客户最近一次所购买的产品属性

19. 敦煌网平台中的物流服务分评级标准，妥投率为多少时，才能达到优秀？（ ）

- A. 30%及以上 B. 60%及以上
C. 80%及以上 D. 90%及以上

20. 根据敦煌网平台规则，卖家发布的以下产品哪个可以通过平台审核？（ ）

- A. 一件价格为 0.01 美元的羽绒服
B. 含有“upgrade”关键词的 U 盘产品
C. 展示服饰的图片上含有一个明显的敦煌网店铺水印
D. 含有黄色液体的雾化器

（二）实施条件

项目	基本实施条件	备注
场地	每个商务英语实训室配置 40 个操作台面和座位，每个实训室照明通风良好。	必备
设备	每个商务英语实训室配有 1 台服务器、40—50 台计算机，并安装 Office 办公软件，配置局域网。	必备
测评专家	每 40 名考生配备 1 名考评员。考评员要求具备至少二年以上从事跨境电商工作经验或三年以上商务英语实践教学指导经历。	必备

（三）考核时量

考试时间：30 分钟

（四）评分标准

模块总分	评价内容	配分	考核点	备注

跨岗位综合技能（总分100分，占总评分的20%）	职业素养与操作规范（10分）	职业素养（6分）	2分	（1）具备跨境电商从业人员基本素质，认真严谨、耐心细致、恪守信誉、实事求是、服从安排，听从指挥、举止文明，记2分。	在考试过程中不服从安排、举止不得当者，记0分。
			2分	（2）具备跨境电商从业人员良好的翻译素养，认真严谨，耐心细致，记2分。	考试过程中出现与所述能力及素养不符，扣1-2分。
			2分	（3）具备外贸从业人员良好的沟通能力、表达能力和合作意识，待人真诚礼貌，记2分。	考试过程中出现与所述能力及素养不符，扣1-2分。
		操作规范（4分）	2分	（1）具备使用办公设备和 Office 办公软件的能力，在考核过程中以及考核结束后，不私自更换电脑、不随意关闭或重启电脑，没征求监考老师同意不随意提前或推迟交卷，记2分。	若私自更换电脑、随意关闭或重启电脑，记0分。
			2分	（2）能严格遵守企业 6S 管理要求（整理、整顿、清扫、清洁、素养、安全），记2分。	若未遵守企业 6S 管理要求，记0分。
		任务（90分）		18分	B2C 跨境电子商务平台产品推广等业务操作环节作答。
	18分			B2C 跨境电子商务平台产品开发等业务操作环节作答。	从四个选项中选择最适合的答案，每题 4.5 分，多选、错选、漏选，均不得分。
	18分			B2C 跨境电子商务平台引流营销等业务操作环节作答。	从四个选项中选择最适合的答案，每题 4.5 分，多选、错选、漏选，均不得分。
	18分			B2C 跨境电子商务平台客户服务等业务操作环节作答。	从四个选项中选择最适合的答案，每题 4.5 分，多选、错选、漏选，均不得分。

			18分	B2C 跨境电子商务平台规则等业务操作环节作答。	从四个选项中选择最适合的答案，每题 4.5 分，多选、错选、漏选，均不得分。
--	--	--	-----	--------------------------	--

4. 试题编号：3-1-4 跨境电商平台综合应用能力

(一) 任务描述

内容：仔细阅读命题，就 B2C 跨境电子商务平台产品推广、产品开发、引流营销、客户服务、平台规则等业务操作环节作答。

要求：从 A、B、C、D，四个选项中选择一个最适合的答案，每题 1 分，多选、错选、漏选，均不得分。

1. 根据阿里巴巴国际站的用户违规处罚标准，若卖家累计被扣 12 分将会受到怎样的处罚？（ ）

- A. 严重警告
- B. 搜索屏蔽 7 天&旺铺屏蔽 7 天
- C. 搜索屏蔽 14 天&旺铺屏蔽 14 天
- D. 全店商品退回

2. 在速卖通平台，商家以自有品牌（商标为 R 或 TM 状态），或者持他人品牌授权文件在速卖通开设的店铺，这种店铺的类型是（ ）。

- A. 官方店
- B. 专卖店
- C. 专营店
- D. 旗舰店

3. 下列词组中，哪个表示“企业店铺”？（ ）

- A. Basic Store
- B. Premium Store
- C. Anchor Store
- D. Enterprise Store

4. 请为划线处单词选择最合适的中文解释。（ ）

You have chosen one of the best-selling products in our store.

A. 最贵的 B. 最便宜的 C. 最畅销的 D. 质量最好的

5. 在敦煌网平台发布产品时，最多可以为每个产品添加几个关键词？

()

A. 1 个 B. 3 个 C. 6 个 D. 10 个

6. 我国实行的法定计量单位是采用（ ）。

A. 公制 B. 英制 C. 美制 D. 国际单位制

7. 速卖通平台中，卖家上架商品的标题最多可以有多少个字符？

()

A. 100 个 B. 128 个 C. 136 个 D. 150 个

8. 在 eBay 平台，如果一位买家拍下产品后超过了（ ）天未付款，则卖家也无法向其发送 invoice

A. 7 B. 10 C. 30 D. 60

9. 在亚马逊平台，根据违规行为的严重程度，针对商品质量违规行为的后果，平台可能会对卖家采取措施不包括下列哪个？（ ）

A. 取消商品 B. 限制发布权限
C. 暂停发布权限 D. 取消或冻结发布权限

10. 以下关于南美市场描述不正确的是（ ）。

A. 南美洲地广人稀，资源丰富
B. 南美大陆语言以西班牙语、葡萄牙语为主
C. 南美大陆语言以英语为主

D. 南美洲国土面积最大的国家是巴西

11. 跨境进口是指海外卖家将商品直销给国内买家，一般是国内消费者访问境外商家的购物网站选择商品，然后下单，由境外卖家发国际物流给国内消费者。目前主要有两种模式：保税模式和直邮模式，这两种模式都以个人物品入境申报，缴纳（ ）。

A. 增值税 B. 消费税 C. 行邮税 D. 关税

12. 判断引号中的文字表述是否正确。（ ）

“eBay 专门制定了 ‘VeRO’ (Verified Rights Owner) 计划，只有知识产权所有者才可以举报侵犯了他们版权、商标权或其他知识产权的 eBay 物品刊登。”

A. 正确 B. 错误

13. 选择合适的选项补全句子。

When customers use Amazon’ s search engine and browse structure, they expect to _____ relevant and accurate _____. ()

A. found, result B. find, results
C. finds, results D. finding, result

14. 选择合适的选项补全句子。

We are expecting to _____ long-term business relations with you.
()

A. describe B. estate C. estimate D. establish

15. 选择合适的选项补全句子。

If your order is a _____ one, we could reconsider our price.

()

A. size B. sizing C. sizable D. sizes

16. eBay 不允许有将买家指向 eBay 以外网站的链接, 以下链接不允许的是 ()

A. 产品视频 B. 货运服务
C. 生产商网站 D. 其他有需要的法律信息

17. Wish 平台商家要查看自己店铺有哪些订单不符合付款条件, 应在中心主页面导航栏点击哪个按钮进入下一步操作? ()

A. 订单 B. 客户问题 C. 业绩 D. 违规

18. Wish 平台非常重视订单交付的时效性, 为保证时效, 平台建议卖家的处理方式是 ()。

A. 迅速履行订单, 并使用可靠、有效的配送方法
B. 适当刷单以提高店铺的物流表现
C. 物流时效不佳地区的订单, 应在订单履行前取消
D. 物流高峰期的时候, 应先使用虚假单号发货以安抚客户避免退货

19. Wish 平台规定自 2018 年 10 月 22 日起, 凡从中国大陆直接发出的订单, 需使用哪种物流方式配送? ()

A. 新加坡挂号小 B. 中邮挂号小包
C. e-Packet D. Wish 邮

20. 速卖通产品图片的背景底色一般为 ()

A. 白色 B. 黑色

C. 红色

D. 蓝色

(二) 实施条件

项目	基本实施条件	备注
场地	每个商务英语实训室配置 40 个操作台面和座位,每个实训室照明通风良好。	必备
设备	每个商务英语实训室配有 1 台服务器、40—50 台计算机,并安装 Office 办公软件,配置局域网。	必备
测评专家	每 40 名考生配备 1 名考评员。考评员要求具备至少二年以上从事跨境电商工作经验或三年以上商务英语实践教学指导经历。	必备

(三) 考核时量

考试时间: 30 分钟

(四) 评分标准

模块总分		评价内容	配分	考核点	备注
跨岗位综合技能(总分 100 分, 占总评分的 20%)	职业素养与操作规范(10 分)	职业素养(6 分)	2 分	(1) 具备跨境电商从业人员基本素质,认真严谨、耐心细致、恪守信誉、实事求是、服从安排,听从指挥、举止文明,记 2 分。	在考试过程中不服从安排、举止不得当者,记 0 分。
			2 分	(2) 具备跨境电商从业人员良好的翻译素养,认真严谨,耐心细致,记 2 分。	考试过程中出现与所述能力及素养不符,扣 1-2 分。
			2 分	(3) 具备跨境电商从业人员良好的沟通能力、表达能力和合作意识,待人真诚礼貌,记 2 分。	考试过程中出现与所述能力及素养不符,扣 1-2 分。
		操作规范(4 分)	2 分	(1) 具备使用办公设备和 Office 办公软件的能力,在考核过程中以及考核结束后,不私自更换电脑、	若私自更换电脑、随意关闭或重启电脑,记 0

		分)		不随意关闭或重启电脑，没征求监考老师同意不随意提前或推迟交卷，记 2 分。	分。	
			2分	(2) 能严格遵守企业 6S 管理要求（整理、整顿、清扫、清洁、素养、安全），记 2 分。	若未遵守企业 6S 管理要求，记 0 分。	
	任务(90分)			18分	B2C 跨境电子商务平台产品推广等业务操作环节作答。	从四个选项中选择最适合的答案，每题 4.5 分，多选、错选、漏选，均不得分。
				18分	B2C 跨境电子商务平台产品开发等业务操作环节作答。	从四个选项中选择最适合的答案，每题 4.5 分，多选、错选、漏选，均不得分。
				18分	B2C 跨境电子商务平台引流营销等业务操作环节作答。	从四个选项中选择最适合的答案，每题 4.5 分，多选、错选、漏选，均不得分。
				18分	B2C 跨境电子商务平台客户服务等业务操作环节作答。	从四个选项中选择最适合的答案，每题 4.5 分，多选、错选、漏选，均不得分。
				18分	B2C 跨境电子商务平台规则等业务操作环节作答。	从四个选项中选择最适合的答案，每题 4.5 分，多选、错选、漏选，均不得分。

5. 试题编号：3-1-5 跨境电商平台综合应用能力

(一) 任务描述

内容：仔细阅读命题，就 B2C 跨境电子商务平台产品推广、产品开发、引流营销、客户服务、平台规则等业务操作环节作答。

要求：从 A、B、C、D，四个选项中选择一个最适合的答案，每

题 1 分，多选、错选、漏选，均不得分。

1. 判断引号中的文字表述是否正确：（ ）

“卖家在 eBay 平台上开店铺、刊登物品进行销售，全程都不收取任何费用。”

- A. 正确 B. 错误

2. 在速卖通平台，商家经营 1 个及以上他人或自有品牌（商标为 R 或 TM 状态）商品的店铺，这种店铺的类型为（ ）

- A. 官方店 B. 专卖店 C. 专营店 D. 旗舰店

3. 以下关于女式手表的标题写法最为恰当的是（ ）。

A. BEST SELLER WOMEN' S FASHION ROSE GOLD WATCH QUARTZ BUSINESS MUJER WRISTWATCHES

B. Women' s Rose Gold Watch New Casual Quartz Fashion Mujer Wristwatches

C. Free Shipping Rose Gold Watch for Women Casual Quartz Fashion Mujer Wristwatches

D. New Arrival!!! Women Rose Gold Watch Casual Quartz Lady' s Watch

4. 下列哪一项属于亚马逊 FBA 的服务范围？（ ）

- A. 回复客户邮件 B. 上传产品
C. 处理退货 D. 帮助卖家选品

5. 选择一个恰当的选项将英文句子补充完整。

“They look (), but their materials are different.”

- A. like B. alike C. liking D. liked

6. 判断引号中的文字表述是否正确：（ ）

“速卖通数据纵横-选品专家中的热销页面，属性词所在圆圈的颜色越蓝表示竞争越激烈。”

- A. 正确 B. 错误

7. 速卖通平台中，以下哪项简称代表页面浏览量？（ ）

- A. GMV B. UV C. SNS D. PV

8. 在速卖通平台中，买家下单后，卖家拒绝发货的行为，属于下列哪种违规行为？（ ）

- A. 提价销售 B. 成交不卖 C. 强制搭售 D. 出售侵权商品

9. 下方为 4 张不同类型的衣服布料图，其中迷彩布和格子布分别为哪两张图？（ ）



A



B



C



D

- A. 图 A 和图 D B. 图 B 和图 D
C. 图 C 和图 D D. 图 B 和图 C

10. 速卖通主图尺寸为（ ）

- A. 400*400 B. 600*600
C. 800*800 D. 1000*1000

11. 请选择合适的选项，补充下面的英文句子。

We can help you to()the payment problems or cancel the order.

- A. resolve B. reserve
C. reveal D. replace

12. Wish 平台使用 CSV 文件批量上架产品中，“Size”指的是产品尺码。以下哪项是错误的“Size”的填写方式？（ ）

A. M

B. XL

C. 9.5

D. M, L

13. 在亚马逊平台结算报告中的“Variable Closing Fees”指的是（ ）。

A. 固定结算费用

B. 可变结算费用

C. 成交手续费

D. 月租费

14. Wish 商户注册的网址是什么？（ ）

A. https://merchant.wish.cn

B. https://merchant.wish.com

C. https://www.wish.com

D. https://www.wish.cn

15. 在速卖通平台，发现知识产权严重侵权案件，商家有几次申诉机会？（ ）

A. 没有申诉机会

B. 1

C. 2

D. 3

16. 选择正确的选项补全句子。

Search for products by entering the or into the Search Bar at the top of any AliExpress page. ()

A. product name; keyword

B. B. product title; password

C. product name; security code

D. D. shop name; keyword

17. 请仔细阅读英文语句，并选择合适的选项补全该句：G-mart Wireless Sport Headphone with mic and Bluetooth 4.1, made () Cellphones as Samsung.

A. for

B. by

C. on

D. with

18. 请根据子类目选择出其归属的上级类目。子类目：

CPUs/Processors、Memory (RAM)、Motherboards、Graphics/Video Cards。()

- A. 电脑组件
- B. 男装
- C. 儿童保健
- D. 化妆品

19. 判断引号中的文字表述是否正确。()

“在敦煌网平台，带有VIP价格的产品也可参加任何其他促销。展示的VIP价格为折上折价格。”

- A. 正确
- B. 错误

20. 国别域名由两个英文字母所组成，比如：代表中国大陆的是“.cn”，代表澳大利亚的是“.au”，代表欧盟的是“.eu”等等，跨境电商卖家可通过国别域名来判断某个网站平台所在的国家或组织，从而进行细分市场的分析。请问Canada和Bulgaria两个国家的域名后缀分别是？()

- A. “.cd”
- B. “.ca”
- C. “.bu”
- D. “.bg”

(二) 实施条件

项目	基本实施条件	备注
场地	每个商务英语实训室配置 40 个操作台面和座位，每个实训室照明通风良好。	必备
设备	每个商务英语实训室配有 1 台服务器、40—50 台计算机，并安装 Office 办公软件，配置局域网。	必备
测评专家	每 40 名考生配备 1 名考评员。考评员要求具备至少二年以上从事跨境电商工作经验或三年以上商务英语实践教学指导经历。	必备

(三) 考核时量

考试时间：30 分钟

(四) 评分标准

模块总分		评价内容	配分	考核点	备注
跨岗位综合技能（总分100分，占总评分的20%）	职业素养与操作规范（10分）	职业素养（6分）	2分	（1）具备跨境电商从业人员基本素质，认真严谨、耐心细致、恪守信誉、实事求是、服从安排，听从指挥、举止文明，记2分。	在考试过程中不服从安排、举止不得当者，记0分。
			2分	（2）具备跨境电商从业人员良好的翻译素养，认真严谨，耐心细致，记2分。	考试过程中出现与所述能力及素养不符，扣1-2分。
			2分	（3）具备外贸从业人员良好的沟通能力、表达能力和合作意识，待人真诚礼貌，记2分。	考试过程中出现与所述能力及素养不符，扣1-2分。
		操作规范（4分）	2分	（1）具备使用办公设备和 Office 办公软件的能力，在考核过程中以及考核结束后，不私自更换电脑、不随意关闭或重启电脑，没征求监考老师同意不随意提前或推迟交卷，记2分。	若私自更换电脑、随意关闭或重启电脑，记0分。
			2分	（2）能严格遵守企业 6S 管理要求（整理、整顿、清扫、清洁、素养、安全），记2分。	若未遵守企业 6S 管理要求，记0分。
		任务（90分）		18分	B2C 跨境电子商务平台产品推广等业务操作环节作答。
	18分			B2C 跨境电子商务平台产品开发等业务操作环节作答。	从四个选项中选择最适合的答案，每题 4.5 分，多选、错选、漏选，均不得分。

			18分	B2C 跨境电子商务平台引流营销等业务操作环节作答。	从四个选项中选择一个最适合的答案，每题 4.5 分，多选、错选、漏选，均不得分。
			18分	B2C 跨境电子商务平台客户服务等业务操作环节作答。	从四个选项中选择最适合的答案，每题 4.5 分，多选、错选、漏选，均不得分。
			18分	B2C 跨境电子商务平台规则等业务操作环节作答。	从四个选项中选择最适合的答案，每题 4.5 分，多选、错选、漏选，均不得分。

6. 试题编号：3-1-6 跨境电商平台综合应用能力

(一) 任务描述

内容：仔细阅读命题，就 B2C 跨境电子商务平台产品推广、产品开发、引流营销、客户服务、平台规则等业务操作环节作答。

要求：从 A、B、C、D，四个选项中选择一个最适合的答案，每题 1 分，多选、错选、漏选，均不得分。

- 在 eBay 平台上，对刊登的产品图片有一定要求，但是不包括（ ）
 - 每件物品至少包含一张图片
 - 卖家不得在图片上添加文字或图案
 - 图片中必须附带该产品的商标
 - 所有图片的长边不得低于 500 像素
- 跨境运输对货品的包装有具体的要求，以下哪项不属于跨境运输包装的原则和要求？（ ）

- A. 适合运输 B. 便于装卸
C. 保护产品、防盗 D. 连体包装
3. 下列选项中不能表达：“感谢您的订单。”的表述是（ ）
- A. We appreciate for your order.
B. Thank you for your order.
C. We appreciate your order.
D. Thanks for your order.
4. 在速卖通里，如果你的商品出现了支付下跌的状况，下列做法正确的是（ ）。
- A. 优化商品标题和描述，加强引流
B. 主动打电话给买家，提示买家下单
C. 暗示买家成交后返现
D. 不断发送站内信给买家，提示买家下单
5. 全球速卖通平台严禁用户未经授权发布、销售涉嫌侵犯第三方知识产权的商品。其中侵权的类型不包括哪些？（ ）
- A. 商标侵权 B. 人物侵权
C. 著作权侵权 D. 专利侵权
6. 下方为 4 种服饰的工艺处理类型，其中泼墨和破洞效果最为突出的分别为哪两张产品图？（ ）



- A. 图 A 和图 B B. 图 B 和图 C
C. 图 C 和图 D D. 图 B 和图 D

12. What does the “Mfr” represent in the product uploading page of Amazon? ()

- A. Multi Frequency Receiver B. Mass Flow Rate
C. Manufacturer D. Motor Manufacture

13. Wish 平台订单处理流程包括：①配送服务；②打印标签；③确认配送；④发件人信息；⑤包裹详情。下列哪项是正确的流程排序？
()

- A. ⑤④③②① B. ⑤①④③②
C. ⑤④①②③ D. ⑤①②③④

14. 选择合适的选项补全句子。

Our company aims to provide _____ designs with _____ price to young women. ()

- A. trending, afford B. trendy, afford
C. trendy, affordable D. trend, afford

15. 选择合适的选项补全句子。

We focus _____ design and production _____ modern fashion apparels. ()

- A. on, from B. in, to C. in, from D. on, of

16. 选择合适的选项补全句子。

We need 5-7 working days _____ prepare your order according _____ our numerous orders every day. ()

- A. on, to B. in, to C. to, to D. to, of

17. 鑫鑫在敦煌网上销售了一款体温计，但她自开店以来并未向平台提供过任何销售许可证书，她的行为构成 ()。

- A. 一般违规 B. 严重违规 C. 一般违法 D. 严重违法

18、 “Its compact size and unique design make it easy to transport.”这是某店铺一款沙发的产品描述,请选出句中“compact”的正确解释。()

- A. 复杂的 B. 紧凑的 C. 牢固的 D. 精确的

19、 亚马逊平台美国站中“BMVD”是指什么的缩写?()

- A. 电子阅读器和书籍
B. 媒介类商品(图书、音乐、影视)
C. 音箱和家庭影院
D. 漫画与绘画小说

20. 关于亚马逊账号注册,说法错误的是()。

- A. 注册所用的邮箱和电脑要求是没有注册、登录过其他的亚马逊账户
B. 信用卡持卡人与账户注册人必须为同一人
C. 公司账户允许使用个人信用卡
D. 注册完成和账户运营过程中,可随时更换信用卡信息

(二) 实施条件

项目	基本实施条件	备注
场地	每个商务英语实训室配置 40 个操作台面和座位,每个实训室照明通风良好。	必备
设备	每个商务英语实训室配有 1 台服务器、40—50 台计算机,并安装 Office 办公软件,配置局域网。	必备
测评专家	每 40 名考生配备 1 名考评员。考评员要求具备至少二年以上从事跨境电商工作经验或三年以上商务英语实践教学指导经历。	必备

(三) 考核时量

考试时间：30 分钟

(四) 评分标准

模块总分		评价内容	配分	考核点	备注
跨岗位综合技能（总分100分，占总评分的20%）	职业素养与操作规范（10分）	职业素养（6分）	2分	（1）具备跨境电商从业人员基本素质，认真严谨、耐心细致、恪守信誉、实事求是、服从安排，听从指挥、举止文明，记2分。	在考试过程中不服从安排、举止不得当者，记0分。
			2分	（2）具备跨境电商从业人员良好的翻译素养，认真严谨，耐心细致，记2分。	考试过程中出现与所述能力及素养不符，扣1-2分。
			2分	（3）具备跨境电商从业人员良好的沟通能力、表达能力和合作意识，待人真诚礼貌，记2分。	考试过程中出现与所述能力及素养不符，扣1-2分。
		操作规范（4分）	2分	具备使用办公设备和 Office 办公软件的能力，在考核过程中以及考核结束后，不私自更换电脑、不随意关闭或重启电脑，没征求监考老师同意不随意提前或推迟交卷，记2分。	若私自更换电脑、随意关闭或重启电脑，记0分。
			2分	能严格遵守企业 6S 管理要求（整理、整顿、清扫、清洁、素养、安全），记2分。	若未遵守企业 6S 管理要求，记0分。
			18分	B2C 跨境电子商务平台产品推广等业务操作环节作答。	从四个选项中选择最适合的答案，每题4.5分，多选、错选、漏选，均不得分。
	任务（90分）	18分	B2C 跨境电子商务平台产品开发等业务操作环节作答。	从四个选项中选择最适合的答案，每题4.5分，多选、错选、漏选，均不得分。	

			18分	B2C 跨境电子商务平台引流营销等业务操作环节作答。	从四个选项中选择一个最适合的答案，每题 4.5 分，多选、错选、漏选，均不得分。
			18分	B2C 跨境电子商务平台客户服务等业务操作环节作答。	从四个选项中选择一个最适合的答案，每题 4.5 分，多选、错选、漏选，均不得分。
			18分	B2C 跨境电子商务平台规则等业务操作环节作答。	从四个选项选择一个最适合的答案，每题 4.5 分，多选、错选、漏选，均不得分。

7. 试题编号：3-1-7 跨境电商平台综合应用能力

（一）任务描述

内容：仔细阅读命题，就 B2C 跨境电子商务平台产品推广、产品开发、引流营销、客户服务、平台规则等业务操作环节作答。

要求：从 A、B、C、D，四个选项中选择一个最适合的答案，每题 1 分，多选、错选、漏选，均不得分。

- 关于 Wish 平台上传产品，下列说法不正确的是（ ）。
 - 产品上传时提供的信息必须准确
 - Wish 平台上可以销售任何商品
 - Wish 平台上销售的产品不能侵犯他方的知识产权
 - Wish 平台上严禁列出重复的产品
- 关于 Wish 平台的履行订单政策，以下哪些表述是不正确的？（ ）
 - 如果一个订单在 5 天内未履行完成，它将被退款并且相关的产

品将被下架

B. 如果商户的履行率非常低，其账户将被暂停

C. 如果卖家只有一个订单未在 5 天内完成将不会对产品和店铺造成影响

D. 如果因未按期履行订单而导致的订单退款数量非常高，其账户将被暂停

3. 请仔细阅读下面邮件，并选择邮件所表达的内容。（ ）

Dear Pavol,

Thanks for your purchasing in our shop and we are sorry to tell you that the parcel was kept at the Russian Customs.

Status: still in customs clearance

According to the rules of Ali, the buyer is obliged to clear the customs and get the parcel. We also hope you can clear the customs as soon as possible and get your help. Please agree with extending more days to receive it and cancel the dispute kindly.

If there is anything we can help, please feel free to contact us.

Thanks!

Best Regards,

Flora

A. 给买家推荐更多相关产品

B. 解决买家付款困难

C. 恳请客户为货物清关，并撤销纠纷

D. 提醒买家收货后给好评

评

4. “Our cream is lightweight, fast-absorbing and non-greasy.”

这是某店铺一款面霜的产品描述，请选出句中“non-greasy”的正确解释。（ ）

- A. 不油腻的 B. 不易过敏的 C. 不脱妆的 D. 不防水的

5. 选择合适的选项补全句子。

When customers use Amazon's search engine and browse structure, they expect to _____ relevant and accurate _____. ()

- A. found, result B. find, results
C. finds, results D. finding, result

6. 亚马逊平台上卖家选择自行发货，如果客户想要更换更快的物流，以便更快的收到货物，你认为可以给客户更改吗？（ ）

- A. 可以，但需要经过亚马逊平台同意。
B. 不可以，因为是按照客户之前既定运输方式发货，且货物已到美国平台已有发货记录。
C. 可以，客户补上差价即可安排更换。
D. 不可以，操作过程繁琐，且需向亚马逊平台解释。

7. 判断引号中的文字表述是否正确。（ ）

“速卖通平台产品上架时，需要填写的包装重量是产品本身的重量，并非产品包装后的重量。”

- A. 正确 B. 错误

8. 关于速卖通平台店铺的二级域名，以下说法正确的是（ ）。

- A. 二级域名一经注册，不能修改
B. 二级域名注册的修改需根据店铺运营产品类目支付费用
C. 二级域名注册收费，商户自行修改无需费用
D. 买家不能通过二级域名直达店铺页面，故无需设置

9. 在亚马逊平台中，下列哪种商品可在商品详情页面中称作“黄金”

商品？（ ）

- A. 18K 镀金黄铜商品 B. 14K 金商品
- C. 24K 金商品 D. 12K 镀金商品

10. 下列哪种物流方式属于国际商业快递？（ ）

- A. 香港邮政小包 B. 中国邮政小包
- C. E 邮宝 D. UPS

11. 判断引号中的文字表述是否正确。（ ）

“在速卖通卖家后台的排名查询工具中，可以查询商品的搜索排名情况，排名查询工具查询结果与用户搜索结果一定完全一致。”

- A. 正确 B. 错误

12. Wish 平台非常重视订单交付的时效性，为保证时效，平台建议卖家的处理方式是（ ）。

- A. 迅速履行订单，并使用可靠、有效的配送方法
- B. 适当刷单以提高店铺的物流表现
- C. 物流时效不佳地区的订单，应在订单履行前取消
- D. 物流高峰期的时候，应先使用虚假单号发货以安抚客户避免退货

货

13. Wish 平台规定自 2018 年 10 月 22 日起，凡从中国大陆直接发出的订单，需使用哪种物流方式配送？（ ）

- A. 新加坡挂号小包 B. 中邮挂号小包
- C. e-Packet D. Wish 邮

14. EMS 对于货物包装的体积重量限制，同一区域内实行的标准（ ）。

- A. 有所不同 B. 全部统一
- C. 没有要求 D. 区别不大

15. 敦煌网平台中的物流服务分评级标准，妥投率为多少时，才能达到优秀？（ ）

- A. 30%及以上
- B. 60%及以上
- C. 80%及以上
- D. 90%及以上

16. 全球速卖通卖家不可以通过什么方式收到平台的订单通知？（ ）

- A. 短信
- B. 微信
- C. TradeManager
- D. 邮件

17. 速卖通平台中，曝光量能反映出卖家关于产品信息存在的问题，如果曝光量反映出产品很少被买家搜到，则最大的问题是（ ）。

- A. 产品图片缺乏吸引力
- B. 标题里的词都太生僻或不符合买家的语言习惯
- C. 标题里的大词比较多，缺少属性词和流行词
- D. 产品详细属性填写不完整

18. 判断引号中的文字表述是否正确。（ ）

“速卖通平台上传产品时，允许商品的图片以拼图的方式呈现。”

- A. 正确
- B. 错误

19. 派安盈可作为亚马逊平台的第三方收款工具，卖家在注册亚马逊账号时需要关联派安盈账户信息，那么派安盈的英文名字是什么？（ ）

- A. Alipay
- B. PayPal
- C. Payoneer
- D. WebMoney

20. 下列三张手绘衣服图分别属于什么领型，请选择与衣服图片匹配正确的领型选项。（ ）

- A. V-neck、Turn-down collar、Stand collar
- B. Turn-down collar、V-neck、Stand collar

C. V-neck、Stand collar、Turn-down collar

D. Stand collar、Turn-down collar、V-neck



(二) 实施条件

项目	基本实施条件	备注
场地	每个商务英语实训室配置 40 个操作台面和座位,每个实训室照明通风良好。	必备
设备	每个商务英语实训室配有 1 台服务器、40—50 台计算机,并安装 Office 办公软件,配置局域网。	必备
测评专家	每 40 名考生配备 1 名考评员。考评员要求具备至少二年以上从事跨境电商工作经验或三年以上商务英语实践教学指导经历。	必备

(三) 考核时量

考试时间：30 分钟

(四) 评分标准

模块总分		评价内容	配分	考核点	备注
跨岗位综合技能(总分 100 分, 占总评分的 20%)	职业素养与操作规范(10 分)	职业素养(6 分)	2	(1) 具备跨境电商从业人员基本素质,认真严谨、耐心细致、恪守信誉、实事求是、服从安排,听从指挥、举止文明,记 2 分。	在考试过程中不服从安排、举止不得当者,记 0 分。
			2	(2) 具备跨境电商从业人员良好	

			分	的翻译素养,认真严谨,耐心细致,记 2 分。	与所述能力及素养不符,扣 1-2 分。
			2 分	(3) 具备跨境电商从业人员良好的沟通能力、表达能力和合作意识,待人真诚礼貌,记 2 分。	考试过程中出现与所述能力及素养不符,扣 1-2 分。
		操作规范 (4 分)	2 分	(1) 具备使用办公设备和 Office 办公软件的能力,在考核过程中以及考核结束后,不私自更换电脑、不随意关闭或重启电脑,没征求监考老师同意不随意提前或推迟交卷,记 2 分。	若私自更换电脑、随意关闭或重启电脑,记 0 分。
			2 分	(2) 能严格遵守企业 6S 管理要求(整理、整顿、清扫、清洁、素养、安全),记 2 分。	若未遵守企业 6S 管理要求,记 0 分。
	任务(90 分)		18 分	B2C 跨境电子商务平台产品推广等业务操作环节作答。	从四个选项中选择一个最适合的答案,每题 4.5 分,多选、错选、漏选,均不得分。
			18 分	B2C 跨境电子商务平台产品开发等业务操作环节作答。	从四个选项选择一个最适合的答案,每题 4.5 分,多选、错选、漏选,均不得分。
			18 分	B2C 跨境电子商务平台引流营销等业务操作环节作答。	从四个选项选择一个最适合的答案,每题 4.5 分,多选、错选、漏选,均不得分。
			18 分	B2C 跨境电子商务平台客户服务等业务操作环节作答。	从四个选项选择一个最适合的答案,每题 4.5 分,多选、错选、漏选,均不得分。
			18 分	B2C 跨境电子商务平台规则等业务操作环节作答。	从四个选项选择一个最适合的答案,每题 4.5 分,多选、错选、漏选,均不得分。

8. 试题编号：3-1-8 跨境电商平台综合应用能力

(一) 任务描述

内容：仔细阅读命题，就 B2C 跨境电子商务平台产品推广、产品开发、引流营销、客户服务、平台规则等业务操作环节作答。

要求：从 A、B、C、D，四个选项中选择一个最适合的答案，每题 1 分，多选、错选、漏选，均不得分。

1. 关于 Wish 平台的用户服务政策，以下表述正确的是（ ）
 - A. 在 Wish 平台上的退单率只要低于 5%就是正常的
 - B. 严禁对 Wish 用户施予辱骂性行为和语言
 - C. 商户可以要求用户在 Wish 以外的平台付款
 - D. 若产品描述不详细用户想继续了解，商户可以指引用户离开 Wish 平台
2. 在全球速卖通平台，卖家店铺存在什么情况会被平台终止或收回账户？（ ）
 - A. 未通过身份认证
 - B. 一年内连续 90 天未登录速卖通或 TradeManager
 - C. 每天新上架的产品过多
 - D. 店铺上架的产品过少
3. 判断引号中的文字表述是否正确。（ ）

“Wish 平台中，产品在促销期间，商户不能降低产品价格和运费。”

 - A. 正确
 - B. 错误
4. 在速卖通平台，以下婚纱礼服行业主营类目中，哪个类目的商品不

强制要求有商标？（ ）

- A. Special Occasion Dresses 特殊场合服装
- B. Wedding Dresses 婚纱
- C. Wedding Party Dress 婚宴礼服
- D. Wedding Accessories 婚庆配饰

5. “在速卖通平台，卖家将订单链接、运费补差价链接、赠品、定金、新品预告等商品作为特殊商品存在于网站上面，但没有按规定放置到指定的特殊发布类目中。”这属于以下哪种搜索作弊行为？（ ）

- A. 商品发布类目乱发
- B. 商品标题、关键词滥用
- C. 黑五类商品的乱放
- D. 商品价格与运费倒挂

6. “在速卖通平台，卖家将同一件商品恶意发布为多个商品进行销售。”这属于以下哪种搜索作弊行为？（ ）

- A. 重复铺货骗曝光
- B. 商品标题、关键词滥用
- C. 重复开小账号抢曝光
- D. 商品价格与运费倒挂

7. 以下关于速卖通账户注册的说法，错误的是（ ）

- A. 速卖通平台，一个电子邮箱仅能注册一个可出售商品的速卖通账户（主账户）
- B. 注册时需要完成邮箱验证和手机验证
- C. 经过平台批准，可以出租、出借或转让账号
- D. 若在经营期间由于“服务指标”考核不达标被清退或中途退出经营大类，在同一年度内将无法再次申请加入该经营大类

8. 在 eBay 平台，SKU 供需关系分析中，气泡大小代表该 SKU 的销售量，下列说法正确是？（ ）

- A. 气泡越小代表当前销售量越大
- B. 气泡越大代表当前销售量越大

- C. 气泡越大代表当前销售量越小
D. 气泡越小代表当前销售量饱和
9. 在亚马逊平台中，页面右上角的“买家消息”的作用不包括的选项为（ ）。
- A. 可以通过“买家消息”与买家进行沟通，减少亚马逊商城交易保障索赔的申请次数
B. 买家消息允许买家和卖家查看所有的邮件往来，方便双方更加快速合理的解决争议问题
C. 买家消息可以不用理会，因为不是绩效考核的指标
D. 买家消息可以通过电子邮件或者直接从卖家平台进行回复
10. 跨境电商的“三流”指的是。（ ）
- A. 信息流，物流，资金流 B. 信息流，产品流，物流
C. 产品流，技术流，资金流 D. 信息流，产品流，技术流
11. “在速卖通平台，卖家以超低价格发布商品，同时调高运费价格，吸引买家注意，骗取曝光。”这属于以下哪种搜索作弊行为？（ ）
- A. 重复铺货骗曝光 B. 商品标题、关键词滥用
C. 商品销量炒作 D. 商品价格与运费倒挂
12. 以下哪个商品属于亚马逊中国禁止或者限制销售的的商品（ ）
- A. 硬币戒指 B. 人民收藏空册
C. 沉香烟片 D. 收藏类的彩票
13. Wish 平台支持的收款方式不包括（ ）
- A. PayPal（贝宝） B. PayEco（易联支付）
C. 派安盈（Payoneer） D. Alipay（支付宝）
14. 以下哪个示例不是违反 Wish 平台产品差异政策的？（ ）
- A. 一根手机充电线和一个移动电源

- B. 来自同一个制造商的短袖 T 恤、长袖 T 恤
- C. 或来自不同制造商的手机套
- D. 产自同一个制造商的、具有相同设计、功能、材质的玩具，但颜色不同

15. 根据速卖通平台规则，所谓“两高一低”品牌是指（ ）

- A. 高销量、高价格，低纠纷的商品品牌
- B. 高销量、高价格，低投诉的商品品牌
- C. 高纠纷、高投诉，低市场认可度的商品品牌
- D. 高成本、高纠纷，低利润的商品品牌

16. 请选择合适的选项，补充下面的英文句子。

The goods you ordered are () now, and we will contact our supplier to see when they are available.

- A. out of stock B. in stock
- C. new arrivals D. out stock

17. 请选择合适的单词选项，补充下面的英文句子。

The prices of these goods cannot be (), because we' re practically selling at cost now.

- A. reduces B. reducing C. reduced D. reduction

18. 请认真阅读下列邮件内容，并选择合适的邮件主旨。（ ）

Dear valued customers,

We regret to inform you that your item may be delayed on the delivery for the atrocious weather in winter. Owing to the abnormal cold weather, many airlines in our country have been cancelled, and many railways and roads have been closed which directly caused the delivery delayed. We appreciate your

understanding and patience. We will keep tracking the package for you, and try our best to offer you any help. You are also welcome to contact us about more solutions.

Thanks,

Yours Sincerely,

Luca

- A. 严寒气候导致航班货运延误
- B. 由于春节导致货运延误
- C. 提醒买家留评价
- D. 物品未收到沟通邮件

19. 请认真阅读下列邮件内容，并选择合适的邮件主旨。（ ）

Dear valued customer,

According to the coming Chinese New Year, I would like kindly to remind you that, the package would be delayed during this time. Owing to the New Year's holiday, the number of shipping package is greatly increasing, while the post office and customs will have holiday off during this time, which directly affect the handling time. We appreciate your understanding and patience. You are also welcome to contact us about more solutions.

Yours Sincerely,

Calic

- A. 严寒气候导致航班货运延误沟通邮件
- B. 由于春节导致货运延误沟通邮件
- C. 提醒买家留好评

D. 物品未收到沟通

20. 下方为 4 张不同类型的衣服款式、细节图，其中拼色款和卡通画款分别为哪两张图？（ ）



A



B



C



D

A. 图 A 和图 B

B. 图 B 和图 C

C. 图 C 和图 D

D. 图 B 和图 D

(二) 实施条件

项目	基本实施条件	备注
场地	每个商务英语实训室配置 40 个操作台面和座位，每个实训室照明通风良好。	必备
设备	每个商务英语实训室配有 1 台服务器、40—50 台计算机，并安装 Office 办公软件，配置局域网。	必备
测评专家	每 40 名考生配备 1 名考评员。考评员要求具备至少二年以上从事跨境电商工作经验或三年以上商务英语实践教学指导经历。	必备

(三) 考核时量

考试时间：30 分钟

(四) 评分标准

模块总分		评价内容	配分	考核点	备注
跨岗位综合	职业素	职业	2	(1) 具备跨境电商从业人员基本	在考试过程中不

技能（总分100分，占总评分的20%）	养与操作规范（10分）	素养（6分）	分	素质，认真严谨、耐心细致、恪守信誉、实事求是、服从安排，听从指挥、举止文明，记2分。	服从安排、举止不得当者，记0分。
			2分	（2）具备跨境电商从业人员良好的翻译素养，认真严谨，耐心细致，记2分。	考试过程中出现与所述能力及素养不符，扣1-2分。
			2分	（3）具备跨境电商从业人员良好的沟通能力、表达能力和合作意识，待人真诚礼貌，记2分。	考试过程中出现与所述能力及素养不符，扣1-2分。
		操作规范（4分）	2分	（1）具备使用办公设备和 Office 办公软件的能力，在考核过程中以及考核结束后，不私自更换电脑、不随意关闭或重启电脑，没征求监考老师同意不随意提前或推迟交卷，记2分。	若私自更换电脑、随意关闭或重启电脑，记0分。
			2分	（2）能严格遵守企业 6S 管理要求（整理、整顿、清扫、清洁、素养、安全），记2分。	若未遵守企业 6S 管理要求，记0分。
		任务（90分）		18分	B2C 跨境电子商务平台产品推广等业务操作环节作答。
	18分			B2C 跨境电子商务平台产品开发等业务操作环节作答。	从四个选项中选择最适合的答案，每题 4.5 分，多选、错选、漏选，均不得分。
	18分			B2C 跨境电子商务平台引流营销等业务操作环节作答。	从四个选项中选择最适合的答案，每题 4.5 分，多选、错选、漏选，均不得分。
	18分			B2C 跨境电子商务平台客户服务等业务操作环节作答。	从四个选项中选择最适合的答案，每题 4.5 分，多选、错选、漏选，均不得分。
	18分			B2C 跨境电子商务平台规则等业务	从四个选项中选择

			分	操作环节作答。	择一个最适合的答案，每题 4.5 分，多选、错选、漏选，均不得分。
--	--	--	---	---------	-----------------------------------

9. 试题编号：4-1-9 跨境电商平台综合应用能力

（一）任务描述

内容：仔细阅读命题，就 B2C 跨境电子商务平台产品推广、产品开发、引流营销、客户服务、平台规则等业务操作环节作答。

要求：从 A、B、C、D，四个选项中选择一个最适合的答案，每题 1 分，多选、错选、漏选，均不得分。

1. 敦煌网平台账号注册成功后，但未完成敦煌网实名认证和开店测试的账户，均视为（ ）。

- A. 休眠账户 B. 无效账户
C. 期限冻结账户 D. 未认证账户

2. 以下哪一项不属于速卖通的平台活动？（ ）

- A. SuperDeals B. 品牌闪购
C. 全店铺打折 D. 俄罗斯团购

3. 判断引号中的文字表述是否正确：（ ）

“速卖通平台上传产品时，允许商品的图片以拼图的方式呈现。”

- A. 正确 B. 错误

4. 速卖通平台的卖家在促销活动中，单方面强制要求买家必须买下其他商品或服务，方可购买本促销商品的行为，属于下列哪种违规行

为？（ ）

- A. 提价销售
- B. 成交不卖
- C. 强制搭售
- D. 出售侵权商品

5. 判断引号中的文字表述是否正确。（ ）

“在 Wish 平台，卖家搜索不到自己的产品，并不意味着其他用户看不到该产品的推送。只要产品为可售状态，他们就会被推送给 Wish 用户。”

- A. 正确
- B. 错误

6. 在速卖通创建店铺，平台所设店铺类型不包括？（ ）

- A. 官方店
- B. 直营店
- C. 专卖店
- D. 专营店

7. 判断引号中的文字表述是否正确。（ ）

“速卖通平台，采用线上发货的订单，因物流问题产生的纠纷（如妥投地址错误，但卖家填写地址无误的情况），卖家可发起线上发货投诉。”

- A. 正确
- B. 错误

8. 判断引号中的文字表述是否正确。（ ）

“Wish 平台卖家发现一笔交易从“未处理”订单队列中消失了，说明该订单可能被买家取消了或者正处于审核状态中。如果该订单不再出现于“未处理”订单队列中，那么卖家无需对此订单发货。”

- A. 正确
- B. 错误

9. 速卖通重要的站内营销活动（ ）

- A. 直通车
- B. 诚信通

C. 微信

D. 微博

10. 在速卖通平台，发布非约定商品（俗称挂 A 卖 B），是指卖家通过速卖通平台发布或出售未经速卖通许可的品牌的商品，请问以下哪个不属于发布非约定商品的情形？（ ）

A. 卖家未完成 A 品牌的商标资质申请，但却规避发布和售卖 A 品牌

B. 卖家仅申请了 A 品牌，实际发布或售卖 A 和 B 或 C 品牌

C. 卖家仅申请了 A 品牌，实际发布或售卖 B 品牌

D. 卖家申请了 A 品牌，实际发布 A 品牌

11. 判断引号中的文字表述是否正确。（ ）

“在 Wish 平台上，为每个产品添加更多的高质量图片能够有效的增加产品销量并加深用户对产品的了解。帮助用户更全面地浏览产品，进而提高点击率。”

A. 正确

B. 错误

12. 请选择合适的单词选项，补充下面的英文句子。

We promise to give you a full refund if the products are not as ().

A. describe

B. describes

C. described

D. describing

13. eBay 平台进行在线销售，如果是一口价的 listing，其最长在线时长为（ ）天。

A. 10

B. 30

C. 50

D. 100

14. 敦煌网平台中，正常账户如超过一年未登录，则视为（ ）。再次登录时需重新进行实名认证，认证通过后方可正常经营。

- A. 休眠账户 B. 无效账户
C. 期限冻结账户 D. 未认证账户

15. 中国邮政小包和国际 e 邮宝的包裹重量一般不超过（ ）。

- A. 2KG B. 4KG C. 3KG

D. 1KG

16. 请仔细阅读英文语句，并选择合适的选项补全该句：G-mart Wireless Sport Headphone with mic and Bluetooth 4.1, made () Cellphones as Samsung.

- A. for B. by C. on D. with

17. 在敦煌网平台，针对鞋类的产品，买家投诉“货不对版”的描述为“产品描述为真皮材质，实物为PU或其他材质”，对于卖家这种描述不符的行为，平台的裁决意见为？（ ）

- A. 一般不符 B. 中等不符
C. 严重不符 D. 极其不符

18. 在亚马逊平台美国站，卖家收到一笔台式电脑订单，订单内商品数量为2台，订单总销售价格为758美元，若售出成功，那么亚马逊将从该笔订单中扣取的销售佣金为（ ）美元。（根据下表中给出的产品销售佣金率或每件产品最低销售佣金计算）

分类	亚马逊将扣除基于适用百分比计算得出的销售佣金或适用的每件商品最低销售佣金（取二者中的较高者）。	
	销售佣金百分比	适用的每件商品最低销售佣金
电脑	6%	\$0.30

A. 37.90 B. 45.48 C. 113.70 D. 90.96

19. 敦煌网产品上传页面中，关于产品有效期的含义理解正确的一项是（ ）。

A. 从发布产品信息成功那天开始，到产品信息在平台上停止展示那天为止的时间段

B. 在一定的贮存条件下，能够保持产品质量的期限

C. 从买家下单到买家签收货物的时间段

D. 从卖家确认发货直至买家签收货物的时间段

20. 根据亚马逊知识产权政策，以下可作为专利权受到保护的是（ ）。

A. 服装品牌 B. 公司名称

C. 出版书籍 D. 新的图书印刷方法

（二）实施条件

项目	基本实施条件	备注
场地	每个商务英语实训室配置 40 个操作台面和座位，每个实训室照明通风良好。	必备
设备	每个商务英语实训室配有 1 台服务器、40—50 台计算机，并安装 Office 办公软件，配置局域网。	必备
测评专家	每 40 名考生配备 1 名考评员。考评员要求具备至少二年以上从事跨境电商工作经验或三年以上商务英语实践教学指导经历。	必备

（三）考核时量

考试时间：30 分钟

(四) 评分标准

模块总分		评价内容	配分	考核点	备注
跨岗位综合技能（总分100分，占总评分20%）	职业素养与操作规范（10分）	职业素养（6分）	2分	（1）具备跨境电商从业人员基本素质，认真严谨、耐心细致、恪守信誉、实事求是、服从安排，听从指挥、举止文明，记2分。	在考试过程中不服从安排、举止不得当者，记0分。
			2分	（2）具备跨境电商从业人员良好的翻译素养，认真严谨，耐心细致，记2分。	考试过程中出现与所述能力及素养不符，扣1-2分。
			2分	（3）具备跨境电商从业人员良好的沟通能力、表达能力和合作意识，待人真诚礼貌，记2分。	考试过程中出现与所述能力及素养不符，扣1-2分。
		操作规范（4分）	2分	（1）具备使用办公设备和 Office 办公软件的能力，在考核过程中以及考核结束后，不私自更换电脑、不随意关闭或重启电脑，没征求监考老师同意不随意提前或推迟交卷，记2分。	若私自更换电脑、随意关闭或重启电脑，记0分。
			2分	（2）能严格遵守企业 6S 管理要求（整理、整顿、清扫、清洁、素养、安全），记2分。	若未遵守企业 6S 管理要求，记0分。
		任务（90分）		18分	B2C 跨境电子商务平台产品推广等业务操作环节作答。
	18分			B2C 跨境电子商务平台产品开发等业务操作环节作答。	从四个选项中选择最适合的答案，每题4.5分，多选、错选、漏选，均不得分。

			18分	B2C 跨境电子商务平台引流营销等业务操作环节作答。	从四个选项中选择一个最适合的答案，每题 4.5 分，多选、错选、漏选，均不得分。
			18分	B2C 跨境电子商务平台客户服务等业务操作环节作答。	从四个选项中选择最适合的答案，每题 4.5 分，多选、错选、漏选，均不得分。
			18分	B2C 跨境电子商务平台规则等业务操作环节作答。	从四个选项中选择最适合的答案，每题 4.5 分，多选、错选、漏选，均不得分。

10. 试题编号：3-1-10 跨境电商平台综合应用能力

（一）任务描述

内容：仔细阅读命题，就 B2C 跨境电子商务平台产品推广、产品开发、引流营销、客户服务、平台规则等业务操作环节作答。

要求：从 A、B、C、D，四个选项中选择一个最适合的答案，每题 1 分，多选、错选、漏选，均不得分。

1. 在速卖通平台，对于知识产权严重侵权案件，商家有几次申诉机会？（ ）

A. 没有申诉机会 B. 1 次 C. 2 次 D. 3 次

2. 在速卖通平台，某件连衣裙的标题为“Women Dress Fashion Casual Women Dress Vintage Printing Dress Sleeveless Halter Evening Party Prom Swing Dress”，请问这件商品违反了以下哪个搜索作弊

行为? ()

- A. 标题堆砌 B. 黑五类产品错放
C. 重复铺货 D. 描述不符

3. 亚马逊平台美国站不接受下列哪家认证机构提供的真品证书或钻石等级报告? ()

- A. GCAL B. AGS C. IGI D. HRD

4. 以下是跨境电商行业中常见的英文术语, 选项中与之匹配的中文解释全部正确的是 ()。

- | | |
|--------------------------|-----------|
| ①certification report | a. 鉴定报告 |
| ②terms and conditions | b. 规定时限 |
| ③partial refund | c. 部分退款 |
| ④described time limit | d. 产品特征 |
| ⑤retail price | e. 零售价 |
| ⑥product features | f. 库存计划 |
| ⑦A-to-z Guarantee claims | g. 条件和条款 |
| ⑧inventory planning | h. 亚马逊商城交 |

易保障索赔

- A. ①-a ②-d ③-c ④-b ⑤-e ⑥-g ⑦-f ⑧-h
B. ①-a ②-d ③-c ④-b ⑤-e ⑥-g ⑦-h ⑧-f
C. ①-a ②-g ③-c ④-b ⑤-e ⑥-d ⑦-h ⑧-f
D. ①-a ②-g ③-c ④-b ⑤-e ⑥-d ⑦-f ⑧-h

5. 以下是跨境电商行业中常见的英文术语, 选项中与之匹配的中文解

释全部正确的是 ()。

- | | |
|--------------------------|----------|
| ①target audience | a. 目标用户 |
| ②invalid tracking number | b. 上架价格 |
| ③sales promotions | c. 中间手续费 |
| ④flash sale | d. 产品促销 |
| ⑤list price | e. 限时折扣 |
| ⑥deals expire | f. 库存 |
| ⑦inventory | g. 有效期 |
| ⑧brokerage fees | h. 无效运单号 |

- A. ①-a ②-h ③-d ④-e ⑤-b ⑥-g ⑦-f ⑧-c
- B. ①-a ②-h ③-e ④-d ⑤-b ⑥-g ⑦-f ⑧-c
- C. ①-a ②-h ③-d ④-e ⑤-g ⑥-b ⑦-f ⑧-c
- D. ①-a ②-h ③-e ④-d ⑤-g ⑥-b ⑦-f ⑧-c

6. 在速卖通平台中, DSR 评价不包括以下哪一项? ()

- A. 商品描述 B. 品牌感染力
- C. 物流速度 D. 卖家服务

7. 敦煌网是国内领先的专业跨境电子商务平台, 它成立于 () 年。

- A. 2001 B. 2004
- C. 2009 D. 2010

8. 卖家在亚马逊平台中国站申请国内开店或全球开店时, 需要完成亚马逊资质审核, 资质审核工作一般会在材料提交后的_____个工作日内完成。 ()

那天为止的时间段

- B. 在一定的贮存条件下，能够保持产品质量的期限
- C. 从买家下单到买家签收货物的时间段
- D. 从卖家确认发货直至买家签收货物的时间段

14. 以下图片符合速卖通平台“产品图片统一规范”的是（ ）



A



B



C



D

15. 跨境电子商务的英文名称是（ ）。

- A. Cross-border Commerce
- B. Cross-border Electronic Commerce
- C. Cross-border Trade Commerce
- D. Cross-border Communication

16. 请选择一个合适的单词，将英文句子补充完整。

“Before () your product, you need to have all product information ready, including title, image, weight, dimension and so on.”

- A. uploading
- B. dispatching
- C. delivering
- D. pricing

17. 请选出下面这封卖家给买家的站内信的主旨。（ ）

Dear Vincent,

We are glad you have received the goods.

Being a seller on AliExpress, feedback from customers is crucial important tous. 5-star feedback will help us improve our products sales and service.

If you have any other concern or are not so satisfied in any regard, please have no hesitation to contact us firstly.

We will try our best to solve your problem.

Many thanks for your time on this.

Best Regards,

Jayne

A. 处理物流危机并争取好评

B. 解决买家付款困难

C. 给买家推荐更多相关产品

D. 提醒买家收货后给好评

18. Wish 平台订单处理流程包括：①配送服务；②打印标签；③确认配送；④发件人信息；⑤包裹详情。下列哪项是正确的流程排序？

()

A. ⑤④③②①

B. ⑤①④③②

C. ⑤④①②③

D. ⑤①②③④

19. “搜索引擎营销”的英文缩写是()。

A. SEM

B. SNS

C. EMS

D. MSN

20. “在速卖通平台，卖家将同一件商品恶意发布为多个商品进行销售。”这属于以下哪种搜索作弊行为？()

A. 重复铺货骗曝光

B. 商品标题、关键词滥用

C. 重复开小账号抢曝光

D. 商品价格与运费倒挂

(二) 实施条件

项目	基本实施条件	备注
场地	每个商务英语实训室配置 40 个操作台面和座位,每个实训室照明通风良好。	必备
设备	每个商务英语实训室配有 1 台服务器、40—50 台计算机,并安装 Office 办公软件,配置局域网。	必备
测评专家	每 40 名考生配备 1 名考评员。考评员要求具备至少二年以上从事跨境电商工作经验或三年以上商务英语实践教学指导经历。	必备

(三) 考核时量

考试时间：30 分钟

(四) 评分标准

模块总分		评价内容	配分	考核点	备注
跨岗位综合技能（总分 100 分，占总评分的 20%）	职业素养与操作规范（10 分）	职业素养（6 分）	2 分	（1）具备跨境电商从业人员基本素质，认真严谨、耐心细致、恪守信誉、实事求是、服从安排，听从指挥、举止文明，记 2 分。	在考试过程中不服从安排、举止不得当者，记 0 分。
			2 分	（2）具备跨境电商从业人员良好的翻译素养，认真严谨，耐心细致，记 2 分。	考试过程中出现与所述能力及素养不符，扣 1-2 分。
			2 分	（3）具备跨境电商从业人员良好的沟通能力、表达能力和合作意识，待人真诚礼貌，记 2 分。	考试过程中出现与所述能力及素养不符，扣 1-2 分。
		操作规范（4 分）	2 分	（1）具备使用办公设备和 Office 办公软件的能力，在考核过程中以及考核结束后，不私自更换电脑、不随意关闭或重启电脑，没征求监考老师同意不随意提前或推迟交卷，记 2 分。	若私自更换电脑、随意关闭或重启电脑，记 0 分。
			2	（2）能严格遵守企业 6S 管理要	若未遵守企业 6S

			分	求（整理、整顿、清扫、清洁、素养、安全），记 2 分。	管理要求，记 0 分。
任务（90 分）			18 分	B2C 跨境电子商务平台产品推广等业务操作环节作答。	从四个选项中选择一个最适合的答案，每题 4.5 分，多选、错选、漏选，均不得分。
			18 分	B2C 跨境电子商务平台产品开发等业务操作环节作答。	从四个选项中选择最适合的答案，每题 4.5 分，多选、错选、漏选，均不得分。
			18 分	B2C 跨境电子商务平台引流营销等业务操作环节作答。	从四个选项中选择最适合的答案，每题 4.5 分，多选、错选、漏选，均不得分。
			18 分	B2C 跨境电子商务平台客户服务等业务操作环节作答。	从四个选项中选择最适合的答案，每题 4.5 分，多选、错选、漏选，均不得分。
			18 分	B2C 跨境电子商务平台规则等业务操作环节作答。	从四个选项中选择最适合的答案，每题 4.5 分，多选、错选、漏选，均不得分。

11. 试题编号：3-1-11 跨境电商平台综合应用能力

（一）任务描述

内容：仔细阅读命题，就 B2C 跨境电子商务平台产品推广、产品开发、引流营销、客户服务、平台规则等业务操作环节作答。

要求：从 A、B、C、D，四个选项中选择一个最适合的答案，每题 1 分，多选、错选、漏选，均不得分。

1. 企业直接面向消费者销售产品和服务是一种商业零售模式，通常我们使用什么英文缩写来表示该商业模式？（ ）

A. B2B B. B2C C. C2C D. O2O

2. 美国社交网络服务网站 Facebook（脸书）的主要创始人是下面哪一位？（ ）

A. 马化腾 B. 马克·扎克伯格
C. 马云 D. 埃隆·马斯克

3. 敦煌网商户的注册网址是（ ）。

A. seller.dhgate.com B. seller.dh.com
C. www.dhgate1.com D. www.dh.com

4. 下列选项中哪个商品能使用 E 邮宝寄送？（ ）

A. 总重 1.5kg 的防晒喷雾
B. 总重 2.05kg 的女士高跟鞋
C. 总重 2kg 的子弹壳
D. 总重 1.8kg 的女士平底鞋

5. 请判断下列哪一个标题属于关键词堆砌情况？（ ）

A. 2015 New Women's Summer Dress V Neck Sleeveless Sexy Cocktail Party Slim Fit Casual Dresses Work Wear XE3315

B. Sexy Slim Autumn Dress New Fashion Letter Printed Long Sleeve Hoody ONY2208

C. 2015 Casual Women Party Dresses Letter Print Hooded Front Pocket Long Sleeve Slim Black Gray White # 81022

D. Lady Faux Leather dress mini dress Women sexy Lace dress slim fitted night bar Club dresses black red Hot catsuit

- A. 正确 B. 错误

12. 以下哪个属于流量词? ()

- A. longsleeve B. men' shirts
C. wholesale D. cotton

13. 速买通产品详情页中不包含哪一项? ()

- A. 产品价格 B. 关联营销
C. 网购流程图 D. 产品说明图

14. 依靠 WEB2.0 技术发展起来的, 允许互联网络用户撰写、分享、评价、讨论、相互沟通的网站、技术和平台 ()

- A. 广告 B. 社交媒体
C. 促销 D. 营销

15. 在亚马逊平台美国站, 卖家收到一笔图书订单 (非租赁), 订单商品为漫画书 1 本, 订单总销售价格为 1.85 美元, 若售出成功, 那么亚马逊将从该笔订单中扣取的销售佣金为 () 美元。(根据下表中给出的产品销售佣金率或每件产品最低销售佣金计算)

分类	亚马逊将扣除基于适用百分比计算得出的销售佣金或适用的每件商品最低销售佣金 (取二者中的较高者)。	
	销售佣金百分比	适用的每件商品最低销售佣金
图书	15%	\$0.30

- A. 0.28 B. 0.15 C. 0.30 D. 0.24

16. 根据亚马逊平台美国站商品捆绑销售政策, 以下描述错误的是 ()。

- A. 捆绑商品图片、特性和描述必须遵守亚马逊的商品发布政策
B. 一旦创建捆绑商品, 则不可修改该捆绑商品的内含商品
C. 捆绑商品中任何单件商品的编码均可用作该捆绑商品的编码
D. 如果发布捆绑商品, 则必须接受整个捆绑商品作为单件商品进

行退货和退款

17. 请为划线处单词选择最合适的中文解释：（ ）

As to specific rates, please consult your local customs office.

A. 特殊的 B. 具体的 C. 专业的 D. 便宜的

18. 请选择合适的选项，补充下列英文句子：

It will take 5-10 days to () your destination, but please check the tracking information for updated information.

A. reach B. leave C. inform D. arrive

19. 请选择合适的选项，补充下列英文句子：

International shipping requires more () shipping procedures, that make the post time between two countries is always longer than domestic post.

A. complicate B. complicated

C. complicates D. complicating

20. 卖家在敦煌网平台上传产品时，产品标题栏最多可填写（ ）个字符。

A. 80 B. 128 C. 140 D. 150

（二）实施条件

项目	基本实施条件	备注
场地	每个商务英语实训室配置 40 个操作台面和座位，每个实训室照明通风良好。	必备
设备	每个商务英语实训室配有 1 台服务器、40—50 台计算机，并安装 Office 办公软件，配置局域网。	必备
测评专家	每 40 名考生配备 1 名考评员。考评员要求具备至少二年以上从事跨境电商工作经验或三年以上商务英语实践教学指导经历。	必备

(三) 考核时量

考试时间：30 分钟

(四) 评分标准

模块总分		评价内容	配分	考核点	备注
跨岗位综合技能（总分 100 分，占总评分的 20%）	职业素养与操作规范（10 分）	职业素养（6 分）	2 分	（1）具备跨境电商从业人员基本素质，认真严谨、耐心细致、恪守信誉、实事求是、服从安排，听从指挥、举止文明，记 2 分。	在考试过程中不服从安排、举止不得当者，记 0 分。
			2 分	（2）具备跨境电商从业人员良好的翻译素养，认真严谨，耐心细致，记 2 分。	考试过程中出现与所述能力及素养不符，扣 1-2 分。
			2 分	（3）具备跨境电商从业人员良好的沟通能力、表达能力和合作意识，待人真诚礼貌，记 2 分。	考试过程中出现与所述能力及素养不符，扣 1-2 分。
		操作规范（4 分）	2 分	（1）具备使用办公设备和 Office 办公软件的能力，在考核过程中以及考核结束后，不私自更换电脑、不随意关闭或重启电脑，没征求监考老师同意不随意提前或推迟交卷，记 2 分。	若私自更换电脑、随意关闭或重启电脑，记 0 分。
			2 分	（2）能严格遵守企业 6S 管理要求（整理、整顿、清扫、清洁、素养、安全），记 2 分。	若未遵守企业 6S 管理要求，记 0 分。
		任务（90 分）		18 分	B2C 跨境电子商务平台产品推广等业务操作环节作答。

			18分	B2C 跨境电子商务平台产品开发等业务操作环节作答。	从四个选项中选择一个最适合的答案，每题 4.5 分，多选、错选、漏选，均不得分。
			18分	B2C 跨境电子商务平台引流营销等业务操作环节作答。	从四个选项中选择一个最适合的答案，每题 4.5 分，多选、错选、漏选，均不得分。
			18分	B2C 跨境电子商务平台客户服务等业务操作环节作答。	从四个选项中选择最适合的答案，每题 4.5 分，多选、错选、漏选，均不得分。
			18分	B2C 跨境电子商务平台规则等业务操作环节作答。	从四个选项中选择最适合的答案，每题 4.5 分，多选、错选、漏选，均不得分。

12. 试题编号：3-1-12 跨境电商平台综合应用能力

(一) 任务描述

内容：仔细阅读命题，就 B2C 跨境电子商务平台产品推广、产品开发、引流营销、客户服务、平台规则等业务操作环节作答。

要求：从 A、B、C、D，四个选项中选择一个最适合的答案，每题 1 分，多选、错选、漏选，均不得分。

1. 在 eBay 平台上刊登产品，listing 中至少应上传一张图片，图片像素应该在（ ）和（ ）之间。

- A. 500, 800 B. 500, 1600
C. 800, 1200 D. 800, 1600

2. 根据速卖通平台规则中关于违规行为定义匹配正确的违规行为名称。其中匹配正确的选项是（ ）。

违规行为：	
①	买家下单后，卖家拒绝发货的行为。
②	买家下单后，卖家未经买家许可，单方面提高商品和物流价格的行为。

- A. ①—不正当谋利 B. ①—成交不卖
 B. ②—出售侵权商品 D. ②—侵权

3. 请选择合适的选项，补充下列英文句子：

International shipping requires more()shipping procedures, that make the post time between two countries is always longer than domestic post.

- A. complicate B. complicated
 C. complicates D. complicating

4. eBay 平台海外仓管理政策中提出卖家刊登物品所在地一定要属实，不能影响买家体验，下列选项中物品所在地显示的范例正确是（ ）。

- A. 美国，中国 B. 北京，中国
 C. 香港，英国 D. 全世界，英国

5. 关于国际 e 邮宝 (e-Packet) 重量和尺寸的规定，下列哪些选项的说法是不正确的？（ ）

- A. 单件货物重量在 2KG 以内
 B. 单件最大尺寸：长宽厚之和小于 109 厘米，且最长一边小于

60 厘米

C. 单件圆卷邮件的最大尺寸：直径的两倍和长度合计不超过 104 厘米，长度不得超过 90 厘米

D. 单件圆卷邮件的最小尺寸：直径的两倍和长度合计不小于 17 厘米，长度不小于 11 厘米

6. 在敦煌网平台，当优惠券可以与店内的所有促销活动同时使用时，那么价格的计算规则是怎么样的？（ ）

A. 先计算优惠券，再计算折扣或直降，最后计算满减

B. 先计算满减，再计算折扣或直降，最后计算优惠券

C. 先计算优惠券，再计算满减，最后计算折扣或直降

D. 先计算折扣或直降，再计算满减，最后计算优惠券

7. 敦煌网店铺服务分以百分制计算，服务分划分为四大能力项，请问这四大能力项占百分制的比重从高至低排序正确的是（ ）

A. 商品能力分>物流能力分>服务能力分>客户维护能力分

B. 商品能力分>物流能力分>客户维护能力分>服务能力分

C. 客户维护能力分>商品能力分>物流能力分>服务能力分

D. 商品能力分>服务能力分>物流能力分>客户维护能力分

8. “An online auction and shopping website in which people and businesses buy and sell a wide variety of goods and services worldwide. It was founded by Pierre Omidyar in 1995, and became a notable success story of the dot-com bubble.” 这描述的是以下哪个电商平台？（ ）

A. Amazon B. EBay C. Wish D. AliExpress

9. 跨境电商中专业术语“每点击成本”的英文缩写是（ ）

A. CPA B. CPM C. CPC D. CPR

10. Wish 商户通过进入平台手动添加产品页面来手动添加产品（非批量上传），共需要经过以下以下步骤：①输入产品基本信息；②添加国家/地区运费；③上传产品图片；④生成产品变量；⑤添加颜色&尺码；⑥添加价格&存货；⑦添加可选产品属性。请问系统默认的正确顺序是（ ）

A. ①③⑦⑤②⑥④ B. ①⑤④③②⑥⑦

C. ①③⑥②⑤④⑦ D. ①②③④⑥⑤⑦

11. 在速卖通平台上，一个专卖店可以申请的品牌数量有多少个？
（ ）

A. 仅 1 个 B. 必须两个以上

C. 两个 D. 可多个

12. 请选择合适的选项，补充下面的英文句子。

The goods you ordered are（ ）now, and we will contact our supplier to see when they are available.

A. out of stock B. in stock

C. new arrivals D. out stock

13. 请选择合适的单词选项，补充下面的英文句子。

The prices of these goods cannot be（ ），because we' re practically selling at cost now.

A. reduces B. reducing

C. reduced D. reduction

14. 请选择合适的单词选项，补充下面的英文句子。

Our prices are very competitive compared () those of similar products in other stores.

A. in

B. to

C. with

D. for

15. 纸箱是一种常用的速卖通包装材料，其按形状可以分为普箱（或双翼箱）、全盖箱、天地盒、火柴盒、异型箱（啤盒）等类型，以下属于普箱的是（ ）

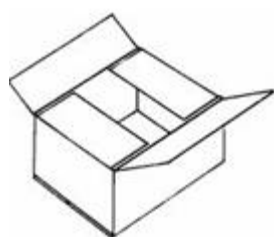

A

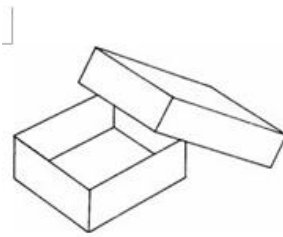

B

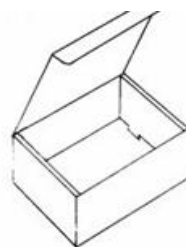

C

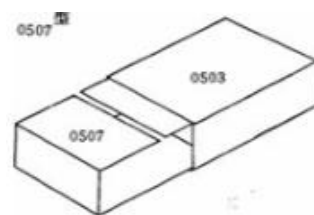

D

16. 速卖通卖家违背承诺严重违规将会被扣除分值（ ）

A. 1分每次

B. 3分每次

D. 12分每次

D. 48分每次

17. 美国买家的购买高峰期是在（ ）节日前后

A. 母亲节

B. 父亲节

C. 感恩节

D. 劳动节

18. 判断引号中的文字表述是否正确。（ ）

“速卖通平台产品上架时，需要填写的包装重量是产品本身的重量，并非产品包装后的重量。”

- A. 正确 B. 错误

19. Wish 平台产品上架时, Color 属性在服装或首饰类产品中, 每个颜色变量对应着唯一 SKU 及库存水平。以下哪项是错误的“Color”填写方式? ()

- A. Blue B. Blue & Black & White
C. Blue & Black D. Yellow & Purple

20. 在亚马逊平台, “Inventory Reconciliation” 是指库存报告中的什么含义? ()

- A. 亚马逊库存 B. 预留库存
C. 库存对账 D. 库存调整

(二) 实施条件

项目	基本实施条件	备注
场地	每个商务英语实训室配置 40 个操作台面和座位, 每个实训室照明通风良好。	必备
设备	每个商务英语实训室配有 1 台服务器、40—50 台计算机, 并安装 Office 办公软件, 配置局域网。	必备
测评专家	每 40 名考生配备 1 名考评员。考评员要求具备至少二年以上从事跨境电商工作经验或三年以上商务英语实践教学指导经历。	必备

(三) 考核时量

考试时间: 30 分钟

(四) 评分标准

模块总分		评价内容	配分	考核点	备注
跨岗位综合技能（总分100分，占总评分的20%）	职业素养与操作规范（10分）	职业素养（6分）	2分	（1）具备跨境电商从业人员基本素质，认真严谨、耐心细致、恪守信誉、实事求是、服从安排，听从指挥、举止文明，记2分。	在考试过程中不服从安排、举止不得当者，记0分。
			2分	（2）具备跨境电商从业人员良好的翻译素养，认真严谨，耐心细致，记2分。	考试过程中出现与所述能力及素养不符，扣1-2分。
			2分	（3）具备跨境电商从业人员良好的沟通能力、表达能力和合作意识，待人真诚礼貌，记2分。	考试过程中出现与所述能力及素养不符，扣1-2分。
		操作规范（4分）	2分	（1）具备使用办公设备和 Office 办公软件的能力，在考核过程中以及考核结束后，不私自更换电脑、不随意关闭或重启电脑，没征求监考老师同意不随意提前或推迟交卷，记2分。	若私自更换电脑、随意关闭或重启电脑，记0分。
			2分	（2）能严格遵守企业 6S 管理要求（整理、整顿、清扫、清洁、素养、安全），记2分。	若未遵守企业 6S 管理要求，记0分。
		任务（90分）		18分	B2C 跨境电子商务平台产品推广等业务操作环节作答。
	18分			B2C 跨境电子商务平台产品开发等业务操作环节作答。	从四个选项中选择最适合的答案，每题 4.5 分，多选、错选、漏选，均不得分。
	18分			B2C 跨境电子商务平台引流营销等业务操作环节作答。	从四个选项中选择最适合的答案，每题 4.5 分，多选、错选、漏选，均不得分。

			18分	B2C 跨境电子商务平台客户服务等业务操作环节作答。	从四个选项中选择一个最适合的答案，每题 4.5 分，多选、错选、漏选，均不得分。
			18分	B2C 跨境电子商务平台规则等业务操作环节作答。	从四个选项中选择最适合的答案，每题 4.5 分，多选、错选、漏选，均不得分。

13. 试题编号：3-1-13 跨境电商平台综合应用能力

(一) 任务描述

内容：仔细阅读命题，就 B2C 跨境电子商务平台产品推广、产品开发、引流营销、客户服务、平台规则等业务操作环节作答。

要求：从 A、B、C、D，四个选项中选择一个最适合的答案，每题 1 分，多选、错选、漏选，均不得分。

1. 判断引号中的文字表述是否正确。（ ）

“在敦煌网平台，带有 VIP 价格的产品也可参加任何其他促销。展示的 VIP 价格为折上折价格。”

A. 正确 B. 错误

2. 在亚马逊平台美国站，卖家收到一笔沙发订单，订单内产品数量为 3 套，订单总销售价格为 298 美元，若售出成功，那么亚马逊将从该笔订单中扣取的销售佣金为（ ）美元。（根据下表中给出的产品销售佣金率或每件产品最低销售佣金计算）

分类	亚马逊将扣除基于适用百分比计算得出的销售佣金或适用的每件商品最低销售佣金（取二者中的较高者）。	
	销售佣金百分比	适用的每件商品最低销售佣金
家具和装饰	对于总销售价格中不超过\$200.00的部分，收取15%的销售佣金； 以及对于总销售价格中超过\$200.00的部分，收取10%的销售佣金。	\$0.30

A. 44.70 B. 29.80 C. 39.80 D. 23.84

3. 当注册亚马逊平台卖家时，平台会要求绑定可用于国际付款且符合亚马逊规定的支付工具。亚马逊接受卖家绑定以下哪种付款扣费工具？（ ）

A. 信用卡 B. 预付信用 C. PayPal D. 支票

4. 在敦煌网平台，限制销售的产品是指需要取得商品销售的前置审批、凭证经营、或授权经营等许可证明，才可以发布的产品。对此，卖家须将已取得的合法许可证明提前提交至敦煌网授权邮箱进行审核，审核通过后，方可发布。请问下列产品属于限制销售的是（ ）。

A. 香烟 B. 白酒
C. 血压计 D. 医用针管注射器

5. 在Wish平台上，卖家如要开启“假期模式”，应该在店铺首页页面最先点击哪个控件？（ ）

A. 订单 B. 产品 C. 账户 D. 帮助

6. 以下物流方式属于邮政物流的是（ ）。

A. ePacket B. TOLL C. UPS D. SF

7. 下列选项中申请Wish品牌合作伙伴正确流程是（ ）。

①验证邮箱 ②提交申请文件 ③账号审核 ④验证手机号码

A. ②③①④ B. ②①④③
C. ③②①④ D. ②③④①

8. 选择正确的选项补全句子。 We offer full or partial refunds on any order where your product is sent to you in the ___ style or quantity, where your product quality is ___ your expectation, or where your shipment arrives partially damaged or broken.

（ ）

双翼箱)、全盖箱、天地盒、火柴盒、异型箱(啤盒)等类型,以下属于普箱的是()

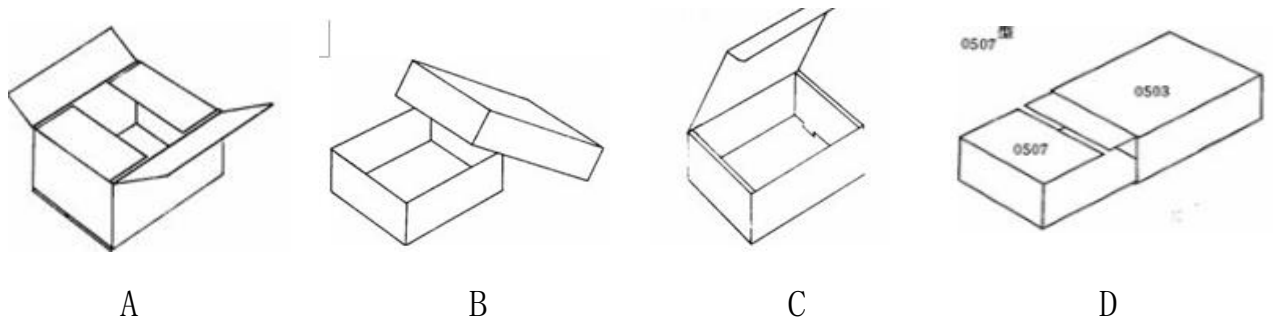

13. 速卖通卖家违背承诺严重违规将会被扣除分值()

- A. 1分每次
- B. 3分每次
- C. 12分每次
- D. 48分每次

14. 以下是某跨境电商销售公司的组织框架简图,针对空缺部分的组织机构填充,以下选项中最为恰当的是()。

- A. ①业务部 ②速卖通客服部 ③采购组
- B. ①跨境销售部 ②亚马逊小组 ③PayPal 管理组
- C. ①跨境销售部 ②美工小组 ③PayPal 管理组
- D. ①业务部 ②亚马逊小组 ③采购组

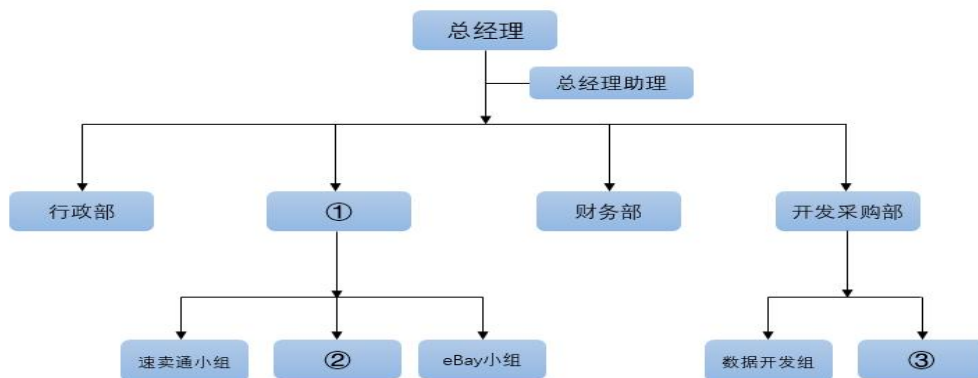

15. 请仔细阅读英文语句,并选择合适的选项补全该句: G-mart Wireless Sport Headphone with mic and Bluetooth 4.1, made () Cellphones as Samsung.

A. for B. by C. on D. with

16. 在敦煌网平台，针对鞋类的产品，买家投诉“货不对版”的描述为“产品描述为真皮材质，实物为PU或其他材质”，对于卖家这种描述不符的行为，平台的裁决意见为？（ ）

- A. 一般不符 B. 中等不符
C. 严重不符 D. 极其不符

17. 以下是跨境电商行业中常见的英文术语，选项中与之匹配的中文解释全部正确的是（ ）。

- | | |
|--------------------------|-----------|
| ①certification report | a. 鉴定报告 |
| ②terms and conditions | b. 规定时限 |
| ③partial refund | c. 部分退款 |
| ④described time limit | d. 产品特征 |
| ⑤retail price | e. 零售价 |
| ⑥product features | f. 库存计划 |
| ⑦A-to-z Guarantee claims | g. 条件和条款 |
| ⑧inventory planning | h. 亚马逊商城交 |

易保障索赔

- A. ①-a ②-d ③-c ④-b ⑤-e ⑥-g ⑦-f ⑧-h
B. ①-a ②-d ③-c ④-b ⑤-e ⑥-g ⑦-h ⑧-f
C. ①-a ②-g ③-c ④-b ⑤-e ⑥-d ⑦-h ⑧-f
D. ①-a ②-g ③-c ④-b ⑤-e ⑥-d ⑦-f ⑧-h

18. 卖家在亚马逊平台中国站申请国内开店或全球开店时，需要完成亚马逊资质审核，资质审核工作一般会在材料提交后的_____个工作

日内完成。()

- A. 1 B. 3 C. 5 D. 7

19. 在 eBay 平台, SKU 供需关系分析中, 气泡大小代表该 SKU 的销售量, 下列说法正确是? ()

- A. 气泡越小代表当前销售量越大
B. 气泡越大代表当前销售量越大
C. 气泡越大代表当前销售量越小
D. 气泡越小代表当前销售量饱和

20. 请选择合适的选项, 补充下列英文句子:

International shipping requires more()shipping procedures, that make the post time between two countries is always longer than domestic post.

- A. complicate B. complicated
C. complicates D. complicating

(二) 实施条件

项目	基本实施条件	备注
场地	每个商务英语实训室配置 40 个操作台面和座位, 每个实训室照明通风良好。	必备
设备	每个商务英语实训室配有 1 台服务器、40—50 台计算机, 并安装 Office 办公软件, 配置局域网。	必备
测评专家	每 40 名考生配备 1 名考评员。考评员要求具备至少二年以上从事跨境电商工作经验或三年以上商务英语实践教学指导经历。	必备

(三) 考核时量

考试时间：30 分钟

(四) 评分标准

模块总分		评价内容	配分	考核点	备注
跨岗位综合技能（总分 100 分，占总评分的 20%）	职业素养与操作规范（10 分）	职业素养（6 分）	2 分	（1）具备跨境电商从业人员基本素质，认真严谨、耐心细致、恪守信誉、实事求是、服从安排，听从指挥、举止文明，记 2 分。	在考试过程中不服从安排、举止不得当者，记 0 分。
			2 分	（2）具备跨境电商从业人员良好的翻译素养，认真严谨，耐心细致，记 2 分。	考试过程中出现与所述能力及素养不符，扣 1-2 分。
			2 分	（3）具备跨境电商从业人员良好的沟通能力、表达能力和合作意识，待人真诚礼貌，记 2 分。	考试过程中出现与所述能力及素养不符，扣 1-2 分。
		操作规范（4 分）	2 分	（1）具备使用办公设备和 Office 办公软件的能力，在考核过程中以及考核结束后，不私自更换电脑、不随意关闭或重启电脑，没征求监考老师同意不随意提前或推迟交卷，记 2 分。	若私自更换电脑、随意关闭或重启电脑，记 0 分。
			2 分	（2）能严格遵守企业 6S 管理要求（整理、整顿、清扫、清洁、素养、安全），记 2 分。	若未遵守企业 6S 管理要求，记 0 分。
			18 分	B2C 跨境电子商务平台产品推广等业务操作环节作答。	从四个选项中选择最适合的答案，每题 4.5 分，多选、错选、漏选，均不得分。
	任务（90 分）	18 分	B2C 跨境电子商务平台产品开发等业务操作环节作答。	从四个选项中选择最适合的答案，每题 4.5 分，多选、错选、漏选，均不得分。	

			18分	B2C 跨境电子商务平台引流营销等业务操作环节作答。	从四个选项中选择一个最适合的答案，每题 4.5 分，多选、错选、漏选，均不得分。
			18分	B2C 跨境电子商务平台客户服务等业务操作环节作答。	从四个选项中选择最适合的答案，每题 4.5 分，多选、错选、漏选，均不得分。
			18分	B2C 跨境电子商务平台规则等业务操作环节作答。	从四个选项中选择最适合的答案，每题 4.5 分，多选、错选、漏选，均不得分。

14. 试题编号：3-1-14 跨境电商平台综合应用能力

(一) 任务描述

内容：仔细阅读命题，就 B2C 跨境电子商务平台产品推广、产品开发、引流营销、客户服务、平台规则等业务操作环节作答。

要求：从 A、B、C、D，四个选项中选择一个最适合的答案，每题 1 分，多选、错选、漏选，均不得分。

1. 亚马逊平台卖家必须在订单日期后的（ ）天内向亚马逊确认订单发货。否则，亚马逊将自动取消订单，而且即使卖家已配送订单，也不会获得付款。

- A. 5 B. 10 C. 15 D. 30

2. 速卖通卖家在促销活动中出现违规行为，平台会根据其情节给予相应处罚，以下有关“促销违规处罚”说法错误的是（ ）

- A. 出售侵权商品，平台会取消商家的活动参与权
B. 提价销售，平台会取消商家的活动参与权，并根据其情节严重

程度禁止其参加促销活动 3 至 9 个月

C. 成交不卖，平台会禁止其参加促销活动 6 个月，情节严重的关闭店铺

D. 强制搭售，平台会禁止其参加促销活动 12 个月

3. 在敦煌网平台，买家因个人原因想要退货且卖家售后服务中包含买家无理由退货的，买家可以申请无理由退货。但是，一般情况下，敦煌网平台规定以下哪种产品不适用无理由退货？（ ）

A. 定制的婚纱礼服 B. 手提包

C. 高跟鞋 D. 衬衫

4. “An online auction and shopping website in which people and businesses buy and sell a wide variety of goods and services worldwide. It was founded by Pierre Omidyar in 1995, and became a notable success story of the dot-com bubble.” 这描述的是以下哪个电商平台？（ ）

A. Amazon B. EBay C. Wish D. AliExpress

5. 选择正确的选项补全句子。The process may () several days to several weeks, although DHgate’s goal is to process a refund as () as possible.

A. take; quick B. took; quickly

C. take; quickly D. took; quick

6. 在 eBay 平台上刊登产品，listing 中至少应上传一张图片，图片像素应该在 () 和 () 之间。

A. 500, 800 B. 500, 1600

C. 800, 1200 D. 800, 1600

7. 判断引号中的文字表述是否正确。（ ）

13. 判断引号中的文字表述是否正确：（ ）

“在 Wish 平台，卖家搜索不到自己的产品，并不意味着其他用户看不到该产品的推送。只要产品为可售状态，他们就会被推送给 Wish 用户。”

- A. 正确 B. 错误

14. 判断引号中的文字表述是否正确：（ ）

“Wish 平台卖家发现一笔交易从“未处理”订单队列中消失了，说明该订单可能被买家取消了或者正处于审核状态中。如果该订单不再出现于“未处理”订单队列中，那么卖家无需对此订单发货。”

- A. 正确 B. 错误

15. 跨境电子商务的英文名称是（ ）。

- A. Cross-border Commerce
B. Cross-border Electronic Commerce
C. Cross-border Trade Commerce
D. Cross-border Communication

16. 参考中文描述，选择一个合适的选项使英文句子表述完整。

“第 12583 号合同项下的货物完好无损。”

“The goods under Contract No. 12583 left here _____.”（ ）

- A. in a good condition B. in good condition
C. in good conditions D. in the good condition

17. 以下哪张图片符合亚马逊平台主图片的要求？（ ）

设备	每个商务英语实训室配有 1 台服务器、40—50 台计算机，并安装 Office 办公软件，配置局域网。	必备
测评专家	每 40 名考生配备 1 名考评员。考评员要求具备至少二年以上从事跨境电商工作经验或三年以上商务英语实践教学指导经历。	必备

(三) 考核时量

考试时间：30 分钟

(四) 评分标准

模块总分		评价内容	配分	考核点	备注
跨岗位综合技能（总分 100 分，占总评分的 20%）	职业素养与操作规范（10 分）	职业素养（6 分）	2 分	（1）具备跨境电商从业人员基本素质，认真严谨、耐心细致、恪守信誉、实事求是、服从安排，听从指挥、举止文明，记 2 分。	在考试过程中不服从安排、举止不得当者，记 0 分。
			2 分	（2）具备跨境电商从业人员良好的翻译素养，认真严谨，耐心细致，记 2 分。	考试过程中出现与所述能力及素养不符，扣 1-2 分。
			2 分	（3）具备跨境电商从业人员良好的沟通能力、表达能力和合作意识，待人真诚礼貌，记 2 分。	考试过程中出现与所述能力及素养不符，扣 1-2 分。
		操作规范（4 分）	2 分	（1）具备使用办公设备和 Office 办公软件的能力，在考核过程中以及考核结束后，不私自更换电脑、不随意关闭或重启电脑，没征求监考老师同意不随意提前或推迟交卷，记 2 分。	若私自更换电脑、随意关闭或重启电脑，记 0 分。
			2 分	（2）能严格遵守企业 6S 管理要求（整理、整顿、清扫、清洁、素养、安全），记 2 分。	若未遵守企业 6S 管理要求，记 0 分。

	任务(90分)		18分	B2C 跨境电子商务平台产品推广等业务操作环节作答。	从四个选项中选择一个最适合的答案，每题 4.5 分，多选、错选、漏选，均不得分。
			18分	B2C 跨境电子商务平台产品开发等业务操作环节作答。	从四个选项选择一个最适合的答案，每题 4.5 分，多选、错选、漏选，均不得分。
			18分	B2C 跨境电子商务平台引流营销等业务操作环节作答。	从四个选项选择一个最适合的答案，每题 4.5 分，多选、错选、漏选，均不得分。
			18分	B2C 跨境电子商务平台客户服务等业务操作环节作答。	从四个选项选择一个最适合的答案，每题 4.5 分，多选、错选、漏选，均不得分。
			18分	B2C 跨境电子商务平台规则等业务操作环节作答。	从四个选项选择一个最适合的答案，每题 4.5 分，多选、错选、漏选，均不得分。

15. 试题编号：3-1-15 跨境电商平台综合应用能力

(一) 任务描述

内容：仔细阅读命题，就 B2C 跨境电子商务平台产品推广、产品开发、引流营销、客户服务、平台规则等业务操作环节作答。

要求：从 A、B、C、D，四个选项中选择一个最适合的答案，每题 1 分，多选、错选、漏选，均不得分。

1. 速卖通平台的卖家在促销活动中，单方面强制要求买家必须买下其他商品或服务，方可购买本促销商品的行为，属于下列哪种违规行为？（ ）

- A. 提价销售
- B. 成交不卖
- C. 强制搭售
- D. 出售侵权商品

2. 判断引号中的文字表述是否正确。（ ）

“在 Wish 平台，卖家搜索不到自己的产品，并不意味着其他用户看不到该产品的推送。只要产品为可售状态，他们就会被推送给 Wish 用户。”

- A. 正确
- B. 错误

3. 判断引号中的文字表述是否正确。（ ）

“Payoneer 只支持美元和欧元两种货币收款。”

- A. 正确
- B. 错误

4. 在速卖通平台，卖家发货并填写发货通知后，买家如果没有收到货物或者对收到的货物不满意，最早可以在卖家全部发货多少天后申请退款？（“卖家设置的限时达时间小于 10 天、俄罗斯精品馆订单、本地仓服务订单”情况除外）（ ）

- A. 5 天
- B. 7 天
- C. 10 天
- D. 15 天

5. 判断引号中的文字表述是否正确：（ ）

“在敦煌网平台，对于下架的产品，卖家也可以进行备货管理。”

- A. 正确
- B. 错误

6. 在敦煌平台，添加运费模板时，运费模板名称不能超过（ ）个

字符？

- A. 10 B. 15 C. 20 D. 30

7. 在速卖通 3C 数码配件行业中，出售的移动电源需要通过质量认证，那么下列属于欧盟强制性认证标志的是（ ）。

- A. CCC B. CE C. UL D. ETL

8. 速卖通平台上，买卖双方达成退款协议且买家同意退货后，买家应在达成退款协议后（ ）内完成退货发货并填写发货通知。

- A. 5 天 B. 7 天 C. 10 天 D. 15 天

9. 在 Wish 平台的订单付款政策中，如果订单没有被物流服务商确认发货，那么订单将于商户标记发货（ ）后成为可支付状态。

- A. 45 天 B. 60 天 C. 90 天 D. 120 天

10. 判断引号中的文字表述是否正确：（ ）

“速卖通平台上传产品时，允许商品的图片以拼图的方式呈现。”

- A. 正确 B. 错误

11. 中国邮政平常小包圆筒货物，两倍直径及长度之和不超过（ ）。

- A. 90cm B. 104cm C. 100cm D. 60cm

12. 请选择合适的选项，补充下面的英文句子。

We can help you to () the payment problems or cancel the order.

- A. resolve B. reserve C. reveal D. replace

13. Wish 平台使用 CSV 文件批量上架产品中，“Size”指的是产品尺码。以下哪项是错误的“Size”的填写方式？（ ）

- A. M B. XL C. 9.5 D. M, L

14. 在亚马逊平台结算报告中的“Variable Closing Fees”指的是（ ）。

- A. 固定结算费用 B. 可变结算费用
C. 成交手续费 D. 月租费
15. 关于“eBay 供需分析”的数据更新时间表述正确的是（ ）
A. 每小时更新 B. 每日更新
C. 每周更新 D. 每月更新
16. 对于商家严重扰乱速卖通平台秩序的行为，如果其情节特别严重，平台每次将给予扣（ ）分的处罚。
A. 2 B. 6 C. 12 D. 48
17. 在亚马逊平台，卖家绩效指标“退货不满意率”的英文缩写为（ ）
A. OTDR B. RDR C. CR D. LSR
18. 请仔细阅读下面邮件，并选择邮件所表达的内容。（ ）

Dear Teresa,

Hello! I appreciate the time you have taken to contact us about your order with tracking number: EE756668845CN.

As per the current tracking result, I regret to inform you that your package is undergoing an unusual condition: it returns back to us. The possible reason for returning will be written on the package (incorrect/illegible/incomplete address ;expired retention period; the addressee failed to collect the item; the addressee does not reside at the given addresss; refused to accept by addressee, etc.). I' ll keep you updated once it arrives at our end.

We' re willing to solve this problem by making full refund or replacing one as per your choice.

Please accept my sincere apologies and let us know which method you are preferable to choose.

Have a nice day!

Best Regards,

Flora

- A. 给买家推荐更多相关产品
- B. 解决买家付款困难
- C. 货物被退回，纠纷处理
- D. 提醒买家收货后给好评

19. 请仔细阅读下面邮件，并选择邮件所表达的内容。（ ）

Dear Pedro,

I' m sorry that the goods cannot satisfy you. It' s for sure that you can send it back for refund or exchange. Please kindly return the goods to the following address:

xxxxxxxxxxxxx

Please make sure the returns include all the original products, packages, and accessories in a re-saleable condition.

Please be aware that postage cost for both return and re-sending will be charged on your side. Once we receive the goods, we will arrange the refund or exchange for you.

Thank you!

Best Regards,

Flora

- A. 买家收到货后不喜欢，退货纠纷处理
- B. 解决买家付款困难
- C. 给买家推荐更多相关产品

D. 提醒买家收货后给好评

20. eBay 平台进行在线销售, 如果是一口价的 listing, 其最长在线时长为 () 天。

A. 10

B. 30

C. 50

D. 100

(二) 实施条件

项目	基本实施条件	备注
场地	每个商务英语实训室配置 40 个操作台面和座位, 每个实训室照明通风良好。	必备
设备	每个商务英语实训室配有 1 台服务器、40—50 台计算机, 并安装 Office 办公软件, 配置局域网。	必备
测评专家	每 40 名考生配备 1 名考评员。考评员要求具备至少二年以上从事跨境电商工作经验或三年以上商务英语实践教学指导经历。	必备

(三) 考核时量

考试时间: 30 分钟

(四) 评分标准

模块总分		评价内容	配分	考核点	备注
跨岗位综合技能 (总分 100 分, 占总评分的 20%)	职业素养与操作规范 (10 分)	职业素养 (6 分)	2 分	(1) 具备跨境电商从业人员基本素质, 认真严谨、耐心细致、恪守信誉、实事求是、服从安排, 听从指挥、举止文明, 记 2 分。	在考试过程中不服从安排、举止不得当者, 记 0 分。
			2 分	(2) 具备跨境电商从业人员良好的翻译素养, 认真严谨, 耐心细致, 记 2 分。	考试过程中出现与所述能力及素养不符, 扣 1-2 分。
			2 分	(3) 具备跨境电商从业人员良好的沟通能力、表达能力和合作意	考试过程中出现与所述能力及素

				识，待人真诚礼貌，记 2 分。	养不符，扣 1-2 分。
	操作规范 (4 分)	2 分	(1) 具备使用办公设备和 Office 办公软件的能力，在考核过程中以及考核结束后，不私自更换电脑、不随意关闭或重启电脑，没征求监考老师同意不随意提前或推迟交卷，记 2 分。	若私自更换电脑、随意关闭或重启电脑，记 0 分。	
		2 分	(2) 能严格遵守企业 6S 管理要求（整理、整顿、清扫、清洁、素养、安全），记 2 分。	若未遵守企业 6S 管理要求，记 0 分。	
	任务(90 分)	18 分	B2C 跨境电子商务平台产品推广等业务操作环节作答。	从四个选项中选择最适合的答案，每题 4.5 分，多选、错选、漏选，均不得分。	
		18 分	B2C 跨境电子商务平台产品开发等业务操作环节作答。	从四个选项中选择最适合的答案，每题 4.5 分，多选、错选、漏选，均不得分。	
		18 分	B2C 跨境电子商务平台引流营销等业务操作环节作答。	从四个选项中选择最适合的答案，每题 4.5 分，多选、错选、漏选，均不得分。	
		18 分	B2C 跨境电子商务平台客户服务等业务操作环节作答。	从四个选项中选择最适合的答案，每题 4.5 分，多选、错选、漏选，均不得分。	
		18 分	B2C 跨境电子商务平台规则等业务操作环节作答。	从四个选项中选择最适合的答案，每题 4.5 分，多选、错选、漏选，均不得分。	

16. 试题编号：3-1-16 跨境电商平台综合应用能力

(一) 任务描述

内容：仔细阅读命题，就 B2C 跨境电子商务平台产品推广、产品开发、引流营销、客户服务、平台规则等业务操作环节作答。

要求：从 A、B、C、D，四个选项中选择一个最适合的答案，每题 1 分，多选、错选、漏选，均不得分。

1. 以下是跨境电商行业中常见的英文术语，选项中与之匹配的中文解释全部正确的是（ ）。

- | | |
|--------------------------|----------|
| ①target audience | a. 目标用户 |
| ②invalid tracking number | b. 上架价格 |
| ③sales promotions | c. 中间手续费 |
| ④flash sale | d. 产品促销 |
| ⑤list price | e. 限时折扣 |
| ⑥deals expire | f. 库存 |
| ⑦inventory | g. 有效期 |
| ⑧brokerage fees | h. 无效运单号 |

A. ①-a ②-h ③-d ④-e ⑤-b ⑥-g ⑦-f ⑧-c

B. ①-a ②-h ③-e ④-d ⑤-b ⑥-g ⑦-f ⑧-c

C. ①-a ②-h ③-d ④-e ⑤-g ⑥-b ⑦-f ⑧-c

D. ①-a ②-h ③-e ④-d ⑤-g ⑥-b ⑦-f ⑧-c

2. 在速卖通平台中，DSR 评价不包括以下哪一项？（ ）

A. 商品描述 B. 品牌感染力

C. 物流速度 D. 卖家服务

3. 敦煌网是国内领先的专业跨境电子商务平台，它成立于（ ）年。

A. 2001 B. 2004 C. 2009 D. 2010

4. 卖家在亚马逊平台中国站申请国内开店或全球开店时，需要完成亚马逊资质审核，资质审核工作一般会在材料提交后的_____个工作日内完成。（ ）

A. 1 B. 3 C. 5 D. 7

5. 请认真阅读下列邮件内容，并选择合适的邮件主旨。（ ）

Dear valued customer,

According to the coming Chinese New Year, I would like kindly to remind you that, the package would be delayed during this time. Owing to the New Year's holiday, the number of shipping package is greatly increasing, while the post office and customs will have holiday off during this time, which directly affect the handling time. We appreciate your understanding and patience. You are also welcome to contact us about more solutions.

Yours Sincerely,

Calic

- A. 严寒气候导致航班货运延误沟通邮件
- B. 由于春节导致货运延误沟通邮件
- C. 提醒买家留好评
- D. 物品未收到沟通

6. 下方为 4 张不同类型的衣服款式、细节图，其中拼色款和卡通画款分别为哪两张图？（ ）



A



B



C



D

A. 图 A 和图 B

B. 图 B 和图 C

C. 图 C 和图 D

D. 图 B 和图 D

7. 中国邮政平常小包和挂号小包的区别，不包括（ ）。

A. 收费不一样

B. 时效性不一样

C. 有没有物流追踪信息

D. 单件最高限重不一样

8. 判断引号中的文字表述是否正确。（ ）

“速卖通平台产品上架时，需要填写的包装重量是产品本身的重量，并非产品包装后的重量。”

A. 正确

B. 错误

9. 跨境电商国际物流术语“实际离港时间”的英文缩写是（ ）

A. ETA

B. ETD

C. ATA

D. ATD

10. 选择正确的选项补全句子。

Search for products by entering the or into the Search Bar at the top of any AliExpress page. ()

A. product name; keyword

B. product title; password

C. product name; security code

D. shop name; keyword

11. 请仔细阅读英文语句，并选择合适的选项补全该句：G-mart Wireless Sport Headphone with mic and Bluetooth 4.1, made ()

Cellphones as Samsung.

A. for B. by C. on D. with

12. 速卖通平台中，曝光量能反映出卖家关于产品信息存在的问题，如果曝光量反映出产品很少被买家搜到，则最大的问题是（ ）。

- A. 产品图片缺乏吸引力
- B. 标题里的词都太生僻或不符合买家的语言习惯
- C. 标题里的大词比较多，缺少属性词和流行词
- D. 产品详细属性填写不完整

13. 请根据子类目选择出其归属的上级类目。子类目：CPUs/Processors、Memory (RAM)、Motherboards、Graphics/Video Cards。（ ）

- A. 电脑组件 B. 男装
- C. 儿童保健 D. 化妆品

14. 请选择合适的选项将句子补充完整。It's obvious your package is not _____, so I'm sure the damage was not due to careless handling during transit.（ ）

- A. reinforced B. revealed
- C. referenced D. recommend

15. 在速卖通平台的羽绒服装市场管理规范中，商品标题关键字使用“羽绒”，商品必须满足的含绒量不得低于（ ）。

- A. 30% B. 40% C. 50% D. 60%

16. 下列短语中，哪个表示“准时交货保证”？（ ）

- A. Basic Guarantees B. Advanced Guarantee
- C. Refund Guarantee D. On Time Delivery Guarantee

17. 阿里巴巴国际站针对卖家知识产权严重侵权行为采取记振处罚方

式，根据处罚标准，若卖家严重侵权行为累积被记振三次将会面临怎样的处罚？（ ）

- A. 限权 7 天+考试（若考试未在 7 天内通过最长限权 30 天）
- B. 限权 14 天+考试（若考试未在 14 天内通过最长限权 60 天）
- C. 限权 21 天+考试（若考试未在 21 天内通过最长限权 60 天）
- D. 关闭账号

18. “搜索引擎营销”的英文缩写是（ ）。

- A. SEM
- B. SNS
- C. EMS
- D. MSN

19. 以下哪个不是 Wish 平台禁售的产品？（ ）

- A. 含有淫秽图片的成人杂志
- B. 纹身枪
- C. 高仿的香奈儿口红
- D. 肩背按摩棒

20. 在敦煌网平台，关于店铺装修及发布产品说法正确的是（ ）。

- A. 禁止发布模仿知名品牌代表性图案、底纹或款式的疑似产品
- B. 对于他人原创的图片、文字或视频不可以直接使用但是可以进行二次剪辑后使用
- C. 发布品牌信息前不需要将授权证明发送至平台进行审核
- D. 可以使用图片处理工具遮掩部分图片 logo

（二）实施条件

项目	基本实施条件	备注
场地	每个商务英语实训室配置 40 个操作台面和座位，每个实训室照明通风良好。	必备
设备	每个商务英语实训室配有 1 台服务器、40—50 台计算机，并安装 Office 办公软件，配置局域网。	必备

测评专家	每 40 名考生配备 1 名考评员。考评员要求具备至少二年以上从事跨境电商工作经验或三年以上商务英语实践教学指导经历。	必备
------	---	----

(三) 考核时量

考试时间：30 分钟

(四) 评分标准

模块总分		评价内容	配分	考核点	备注
跨岗位综合技能 (总分 100 分, 占总评分的 20%)	职业素养与操作规范 (10 分)	职业素养 (6 分)	2 分	(1)具备跨境电商从业人员基本素质,认真严谨、耐心细致、恪守信誉、实事求是、服从安排,听从指挥、举止文明,记 2 分。	在考试过程中不服从安排、举止不得当者,记 0 分。
			2 分	(2)具备跨境电商从业人员良好的翻译素养,认真严谨,耐心细致,记 2 分。	考试过程中出现与所述能力及素养不符,扣 1-2 分。
			2 分	(3)具备跨境电商从业人员良好的沟通能力、表达能力和合作意识,待人真诚礼貌,记 2 分。	考试过程中出现与所述能力及素养不符,扣 1-2 分。
	操作规范 (4 分)	2 分	(1)具备使用办公设备和 Office 办公软件的能力,在考核过程中以及考核结束后,不私自更换电脑、不随意关闭或重启电脑,没征求监考老师同意不随意提前或推迟交卷,记 2 分。	若私自更换电脑、随意关闭或重启电脑,记 0 分。	
		2 分	(2)能严格遵守企业 6S 管理要求(整理、整顿、清扫、清洁、素养、安全),记 2 分。	若未遵守企业 6S 管理要求,记 0 分。	
任务 (90 分)		18 分	B2C 跨境电子商务平台产品推广等业务操作环节作答。	从四个选项中选择一个最适合的答案,每题 4.5 分,多选、错选、漏选,均不得分。	

			18分	B2C 跨境电子商务平台产品开发等业务操作环节作答。	从四个选项选择一个最适合的答案,每题 4.5 分,多选、错选、漏选,均不得分。
			18分	B2C 跨境电子商务平台引流营销等业务操作环节作答。	从四个选项选择一个最适合的答案,每题 4.5 分,多选、错选、漏选,均不得分。
			18分	B2C 跨境电子商务平台客户服务等业务操作环节作答。	从四个选项选择一个最适合的答案,每题 4.5 分,多选、错选、漏选,均不得分。
			18分	B2C 跨境电子商务平台规则等业务操作环节作答。	从四个选项选择一个最适合的答案,每题 4.5 分,多选、错选、漏选,均不得分。
			18分	B2C 跨境电子商务平台规则等业务操作环节作答。	从四个选项选择一个最适合的答案,每题 4.5 分,多选、错选、漏选,均不得分。
			18分	B2C 跨境电子商务平台规则等业务操作环节作答。	从四个选项选择一个最适合的答案,每题 4.5 分,多选、错选、漏选,均不得分。

17. 试题编号: 3-1-17 跨境电商平台综合应用能力

(一) 任务描述

内容: 仔细阅读命题,就 B2C 跨境电子商务平台产品推广、产品开发、引流营销、客户服务、平台规则等业务操作环节作答。

要求: 从 A、B、C、D, 四个选项中选择一个最适合的答案, 每题 1 分, 多选、错选、漏选, 均不得分。

1. 派安盈可作为亚马逊平台的第三方收款工具，卖家在注册亚马逊账号时需要关联派安盈账户信息，那么派安盈的英文名字是什么？

()

A. Alipay B. PayPal C. Payoneer D. WebMoney

2. 在 Wish 平台上，如果卖家开启“假期模式”后，所有商品在 Wish 的移动端会被展示为 () 状态。

A. 正在销售 B. 不存在 C. 售罄 D. 禁售

3. 仔细阅读下面句子，并选出作为业务运营标准的选项。()

Making use of data analysis tools refers to product selecting by means of extracting, analyzing and monitoring each nodal data so that the data could be used as the effective basis of the management' s decisions and the staff' s executions, and as the unified scale or standard of business operation.

A. management' s decisions B. staff' s executions
C. the date D. unified scale

4. 以下关于速卖通账户注册的说法，错误的是 ()

A. 速卖通平台，一个电子邮箱仅能注册一个可出售商品的速卖通账户（主账户）

B. 注册时需要完成邮箱验证和手机验证

C. 经过平台批准，可以出租、出借或转让账号

D. 若在经营期间由于“服务指标”考核不达标被清退或中途退出经营大类，在同一年度内将无法再次申请加入该经营大类

5. 订单缺陷率 (ODR) 英文全称: Order _____ Rate 指收到负面反馈、亚马逊商城交易保障索赔或服务信用卡拒付订单的百分比。请选择横线上的单词。()

- A. Defeat (v. 击败) B. Defend (v. 保卫, 防守)
C. Defect (n. 缺陷) D. Defense

6. “Our cream is lightweight, fast-absorbing (吸收快) and non-greasy.” 这是某店铺一款面霜的产品描述, 请选出句中“non-greasy”的正确解释。()

- A. 不油腻的 B. 不易过敏的
C. 不脱妆的 D. 不防水的

7. 选择合适的选项补全句子。

When customers use Amazon's search engine and browse structure, they expect to _____ relevant and accurate _____. ()

- A. found, result B. find, results
C. finds, results D. finding, result

8. Wish 平台非常重视订单交付的时效性, 为保证时效, 平台建议卖家的处理方式是()。

- A. 迅速履行订单, 并使用可靠、有效的配送方法
B. 适当刷单以提高店铺的物流表现
C. 物流时效不佳地区的订单, 应在订单履行前取消
D. 物流高峰期的时候, 应先使用虚假单号发货以安抚客户避免退

货

9. Wish 平台规定自 2018 年 10 月 22 日起，凡从中国大陆直接发出的订单，需使用哪种物流方式配送？（ ）
- A. 新加坡挂号小 B. 中邮挂号小包 C. e-Packet D. Wish 邮
10. 以下哪个属于流量词？（ ）
- A. longsleeve B. men' shirts
C. wholesale D. cotton
11. 速买通产品详情页中不包含哪一项？（ ）
- A. 产品价格 B. 关联营销 C. 网购流程图 D. 产品说明图
12. 关于速卖通平台的商品描述，以下说法不正确的是？（ ）
- A. 服装类的商品描述，可以写上同一组 SKU 的所有尺码信息
B. 属性描述中不能使用特殊字符，不能使用中文输入法
C. 描述不能有公司，促销，物流，运费，或其他任何与商品本身无关的信息
D. 商品描述必须填写
13. 敦煌网平台中，下列哪项不属于“产品价格违规”？（ ）
- A. 产品描述过短 B. 价格不符（超高/超低价）
C. 运费作弊 D. SKU 作弊
14. 在以下情况下，eBay 平台卖家没有资格获得成交费返还的是（ ）
- A. 卖家或者买家同意取消交易
B. 买家没有付款，而且卖家根据要求进入未付款纠纷流程
C. 卖家解决了一个交易的问题，并且给买家 partial refund

D. 买家可向卖家开启“物品未收到”纠纷，卖家将全部支付金额退还给买家

15. 每个平台都有专属的标语，下列平台对应的标语正确的选项是（ ）。

A. eBay—Smart Shopping,Bette Living!

B. 敦煌网—Buy Globally Sell Globally

C. Wish 平台—Shopping Made Happy

D. 速卖通—Shopping Made Fun

16. 以下有关 eBay 平台商品包装的说法，不正确的是（ ）

A. 包装应有清晰的 label 标签

B. 大货、重货或者是易损产品，包装应加固和保护

C. 利用海运发头程运输，建议采用加固包装

D. 循环使用包装盒，之前的标签、地址等信息去掉

17. FBW 是 Wish 提供的仓储和物流服务。以下是企业申请 FBW 美国仓的 5 个步骤，请选择正确的顺序。（ ）

①申请成功后创建配送计划②登录商户③点击现在加入 FBW④上传营业执照及法人身份证⑤向 Wish 提交 FBW 申请⑥选择 FBW US 并提交税务文件

A. ③④⑤①②⑥ B. ③⑤④①②⑥

C. ②③④⑥⑤① D. ①⑤④②③⑥

18. 在速卖通平台，商家以自有品牌（商标为 R 或 TM 状态），或者持他人品牌授权文件在速卖通开设的店铺，这种店铺的类型是（ ）。

A. 官方店 B. 专卖店 C. 专营店 D. 旗舰店

19. 下列词组中，哪个表示“企业店铺”？（ ）

A. Basic Store B. Premium Store
C. Anchor Store D. Enterprise Store

20. 不属于速卖通四种关联推广是（ ）

A. SEO B. 产品关联
C. 店铺活动 D. 联盟营销

（二）实施条件

项目	基本实施条件	备注
场地	每个商务英语实训室配置 40 个操作台面和座位，每个实训室照明通风良好。	必备
设备	每个商务英语实训室配有 1 台服务器、40—50 台计算机，并安装 Office 办公软件，配置局域网。	必备
测评专家	每 40 名考生配备 1 名考评员。考评员要求具备至少二年以上从事跨境电商作经验或三年以上商务英语实践教学指导经历。	必备

（三）考核时量

考试时间：30 分钟

（四）评分标准

模块总分		评价内容	配分	考核点	备注
跨岗位综合技能（总	职业素质	职业素养（6分）	2分	（1）具备跨境电商从业人员基本素质，认真严谨、耐心细致、恪守信誉、实事求是、服从安排，听从指挥、举止文明，记 2 分。	在考试过程中不服从安排、举止不得当者，记 0 分。

分 100 分, 占 总评 分的 20%)	与 操作 规范 (1 0 分)		2 分	(2) 具备跨境电商从业人员良好的翻译素养, 认真严谨, 耐心细致, 记 2 分。	考试过程中出现与所述能力及素养不符, 扣 1-2 分。
			2 分	(3) 具备跨境电商从业人员良好的沟通能力、表达能力和合作意识, 待人真诚礼貌, 记 2 分。	考试过程中出现与所述能力及素养不符, 扣 1-2 分。
		操作 规范 (4 分)	2 分	(1) 具备使用办公设备和 Office 办公软件的能力, 在考核过程中以及考核结束后, 不私自更换电脑、不随意关闭或重启电脑, 没征求监考老师同意不随意提前或推迟交卷, 记 2 分。	若私自更换电脑、随意关闭或重启电脑, 记 0 分。
			2 分	(2) 能严格遵守企业 6S 管理要求 (整理、整顿、清扫、清洁、素养、安全), 记 2 分。	若未遵守企业 6S 管理要求, 记 0 分。
	任 务 (9 0 分)		18 分	B2C 跨境电子商务平台产品推广等业务操作环节作答。	从四个选项中选择一个最适合的答案, 每题 4.5 分, 多选、错选、漏选, 均不得分。
			18 分	B2C 跨境电子商务平台产品开发等业务操作环节作答。	从四个选项中选择一个最适合的答案, 每题 4.5 分, 多选、错选、漏选, 均不得分。
			18 分	B2C 跨境电子商务平台引流营销等业务操作环节作答。	从四个选项中选择一最 适合的 答案, 每题 4.5 分, 多选、错选、漏选, 均不得分。
			18 分	B2C 跨境电子商务平台客户服务等业务操作环节作答。	从四个选项中选择一最 适合的 答案, 每题 4.5 分, 多选、错选、漏选, 均不得分。
			18 分	B2C 跨境电子商务平台规则等业务操作环节作答。	从四个选项中选择一最 适合的 答案, 每题 4.5 分, 多选、错选、漏选, 均不得分。
			18 分	B2C 跨境电子商务平台规则等业务操作环节作答。	从四个选项中选择一最 适合的 答案, 每题 4.5 分, 多选、错选、漏选, 均不得分。

					分，多选、错选、漏选，均不得分。
			18 分	B2C 跨境电商平台规则等业务操作环节作答。	从四个选项中选择一个最适合的答案，每题 4.5 分，多选、错选、漏选，均不得分。

18. 试题编号：3-1-18 跨境电商平台综合应用能力

(一) 任务描述

内容：仔细阅读命题，就 B2C 跨境电商平台产品推广、产品开发、引流营销、客户服务、平台规则等业务操作环节作答。

要求：从 A、B、C、D，四个选项中选择一个最适合的答案，每题 1 分，多选、错选、漏选，均不得分。

1. 2014 年 2 月海关总署决定增列海关监管方式代码“（ ）”，全称“跨境贸易电子商务”，简称“电子商务”，适用于境内个人或电子商务企业通过电子商务交易平台实现交易，并采用“清单核放、汇总申报”模式办理通关手续的电子商务零售进出口商品（通过海关特殊监管区域或保税监管场所一线的电子零售进出口商品除外）。

A. 0110 B. 1210 C. 9610 D. 2210

2. 请为划线处单词选择最合适的中文解释。（ ）

You have chosen one of the best-selling products in our store.

A. 最贵的 B. 最便宜的
B. C. 最畅销的 D. 质量最好的

- A. OTDR B. RDR C. CR D. LSR

10. 请仔细阅读下面邮件，并选择邮件所表达的内容。（ ）

Dear Teresa,

Hello! I appreciate the time you have taken to contact us about your order with tracking number: EE756668845CN.

As per the current tracking result, I regret to inform you that your package is undergoing an unusual condition: it returns back to us. The possible reason for returning will be written on the package (incorrect/illegible/incomplete address ;expired retention period; the addressee failed to collect the item; the addressee does not reside at the given addresss; refused to accept by addressee, etc.). I'll keep you updated once it arrives at our end.

We're willing to solve this problem by making full refund or replacing one as per your choice.

Please accept my sincere apologies and let us know which method you are preferable to choose.

Have a nice day!

Best Regards,

Flora

- A. 给买家推荐更多相关产品 B. 解决买家付款困难
C. 货物被退回，纠纷处理 D. 提醒买家收货后给好评

11. 在 eBay 美国站，卖家选择按年度订购，eBay 平台将按以下哪种方式来收取订购费？（ ）

- A. 按日收取订购费 B. 按月收取订购费

C. 按季度收取订购费

D. 按年度收取订购费

12. 在速卖通平台，发现知识产权严重侵权案件，商家有几次申诉机会？（ ）

A. 没有申诉机会

B. 1

C. 2

D. 3

13. 在 eBay 平台，SKU 供需关系分析中，气泡大小代表该 SKU 的销售量，下列说法正确是？（ ）

A. 气泡越小代表当前销售量越大

B. 气泡越大代表当前销售量越大

C. 气泡越大代表当前销售量越小

D. 气泡越小代表当前销售量饱和

14. 下列四种收款方式中，哪个是 Wish 平台官方支持的？（ ）

A. Tenpay

B. Alipay

C. Payoneer

D. Weibo

15. 社交媒体不包括（ ）

A. Facebook

B. Pinterest

C. Twitter

D. SEO

16. 跨境电商的“三流”指的是。（ ）

A. 信息流，物流，资金流

B. 信息流，产品流，物流

C. 产品流，技术流，资金流

D. 信息流，产品流，技术流

17. 在敦煌网平台，针对鞋类的产品，买家投诉“货不对版”的描述为“产品描述为真皮材质，实物为 PU 或其他材质”，对于卖家这种描述不符的行为，平台的裁决意见为？（ ）

A. 一般不符

B. 中等不符

- C. 严重不符 D. 极其不符

18. 敦煌网产品上传页面中，关于产品有效期的含义理解正确的一项是（ ）。

A. 从发布产品信息成功那天开始，到产品信息在平台上停止展示那天为止的时间段

B. 在一定的贮存条件下，能够保持产品质量的期限

C. 从买家下单到买家签收货物的时间段

D. 从卖家确认发货直至买家签收货物的时间段

19. 阿里巴巴国际站针对卖家知识产权严重侵权行为采取记振处罚方式，根据处罚标准，若卖家严重侵权行为累积被记振三次将会面临怎样的处罚？（ ）

A. 限权 7 天+考试（若考试未在 7 天内通过最长限权 30 天）

B. 限权 14 天+考试（若考试未在 14 天内通过最长限权 60 天）

C. 限权 21 天+考试（若考试未在 21 天内通过最长限权 60 天）

D. 关闭账号

20. “搜索引擎营销”的英文缩写是（ ）。

A. SEM

B. SNS

C. EMS

D. MSN

（二）实施条件

项目	基本实施条件	备注
场地	每个商务英语实训室配置 40 个操作台面和座位，每个实训室照明通风良好。	必备

设备	每个商务英语实训室配有 1 台服务器、40—50 台计算机，并安装 Office 办公软件，配置局域网。	必备
测评专家	每 40 名考生配备 1 名考评员。考评员要求具备至少二年以上从事跨境电商工作经验或三年以上商务英语实践教学指导经历。	必备

(三) 考核时量

考试时间：30 分钟

(四) 评分标准

模块总分	评价内容	配分	考核点	备注
跨岗位综合技能 (总分 100 分，占总评分的 20%)	职业素养与操作规范 (10 分)	2 分	(1)具备跨境电商从业人员基本素质，认真严谨、耐心细致、恪守信誉、实事求是、服从安排，听从指挥、举止文明，记 2 分。	在考试过程中不服从安排、举止不得当者，记 0 分。
		2 分	(2)具备跨境电商从业人员良好的翻译素养，认真严谨，耐心细致，记 2 分。	考试过程中出现与所述能力及素养不符，扣 1-2 分。
		2 分	(3)具备跨境电商从业人员良好的沟通能力、表达能力和合作意识，待人真诚礼貌，记 2 分。	考试过程中出现与所述能力及素养不符，扣 1-2 分。
	操作规范 (4 分)	2 分	(1)具备使用办公设备和 Office 办公软件的能力，在考核过程中以及考核结束后，不私自更换电脑、不随意关闭或重启电脑，没征求监考老师同意不随意提前或推迟交卷，记 2 分。	若私自更换电脑、随意关闭或重启电脑，记 0 分。
		2 分	(2)能严格遵守企业 6S 管理要求（整理、整顿、清扫、清洁、素养、安全），记 2 分。	若未遵守企业 6S 管理要求，记 0 分。
	任务 (90 分)		18 分	B2C 跨境电子商务平台产品推广等业务操作环节作答。

			18分	B2C 跨境电子商务平台产品开发等业务操作环节作答。	从四个选项中选择一个最适合的答案,每题 4.5 分,多选、错选、漏选,均不得分。
			18分	B2C 跨境电子商务平台引流营销等业务操作环节作答。	从四个选项中选择一最最适合的答案,每题 4.5 分,多选、错选、漏选,均不得分。
			18分	B2C 跨境电子商务平台客户服务等业务操作环节作答。	从四个选项中选择一最最适合的答案,每题 4.5 分,多选、错选、漏选,均不得分。
			18分	B2C 跨境电子商务平台规则等业务操作环节作答。	从四个选项中选择一最最适合的答案,每题 4.5 分,多选、错选、漏选,均不得分。
			18分	B2C 跨境电子商务平台规则等业务操作环节作答。	从四个选项中选择一最最适合的答案,每题 4.5 分,多选、错选、漏选,均不得分。
			18分	B2C 跨境电子商务平台规则等业务操作环节作答。	从四个选项中选择一最最适合的答案,每题 4.5 分,多选、错选、漏选,均不得分。

19. 试题编号: 3-1-19 跨境电商平台综合应用能力

(一) 任务描述

内容: 仔细阅读命题,就 B2C 跨境电子商务平台产品推广、产品开发、引流营销、客户服务、平台规则等业务操作环节作答。

要求: 从 A、B、C、D, 四个选项中选择一个最适合的答案, 每题 1 分, 多选、错选、漏选, 均不得分。

1. 关于全球速卖通平台卖家的入驻流程，下列选项中排序正确的是（ ）。

①开通账号 ②完善店铺信息 ③开店经营 ④提交入驻资料 ⑤
缴纳年费

- A. ③④⑤①② B. ③⑤④①②
C. ①④⑤②③ D. ①⑤④②③

2. 亚马逊平台不允许卖家对某些商品分类提供特定类型的促销优惠，其中不包括以下哪一项？（ ）

- A. 媒介类商品：不参与免费配送促销
B. 亚马逊物流订单：不参与免费配送促销
C. 酒类：不参与任何促销
D. 服装类商品：不参与任何促销

3. 在敦煌网中，关于参加团购活动的商品发布规则，以下说法错误的是（ ）。

- A. 产品的展示语种必须与活动设置的平台相对应
B. 必须是已上架且审核通过的产品，且产品有效期大于活动结束日期
C. 产品的运费模板必须支持对应平台语系的国家，必须包含 4 大国际物流和 e 邮宝当中任何一种免运费的物流方式
D. 所发布产品的折扣没有任何要求，卖家可随意设定

4. 以下哪个属于流量词？（ ）

- A. longsleeve B. men' shirts
C. wholesale D. cotton

5. 在 eBay 平台中，销售品类分析中，曝光到浏览的转化率是怎么计

算的？（ ）

- A. 浏览量/曝光量
- B. 曝光量/浏览量
- C. 交易量/浏览量
- D. 交易量/曝光量

6. 卖家在敦煌网平台上传产品时，产品标题栏最多可填写（ ）个字符。

- A. 80
- B. 128
- C. 140
- D. 150

7. 在亚马逊平台美国站，卖家收到一笔台式电脑订单，订单内商品数量为 2 台，订单总销售价格为 758 美元，若售出成功，那么亚马逊将从该笔订单中扣取的销售佣金为（ ）美元。（根据下表中给出的产品销售佣金率或每件产品最低销售佣金计算）

分类	亚马逊将扣除基于适用百分比计算得出的销售佣金或适用的每件商品最低销售佣金（取二者中的较高者）。	
	销售佣金百分比	适用的每件商品最低销售佣金
电脑	6%	\$0.30

- A. 37.90
- B. 45.48
- C. 113.70

D. 90.96

8. 选择正确的选项补全句子。 We offer full or partial refunds on any order where your product is sent to you in the ___ style or quantity, where your product quality is ___ your expectation, or where your shipment arrives partially damaged or broken. ()

- A. right; below
- B. wrong; over
- C. right; below
- D. wrong; below

9. 下图为 eBay 平台美国站商家某商品展示页面，该商品设置了何种促销活动？（ ）

- A. Order discount
- B. Sales event
- C. Codeless coupon
- D. Volume pricing



10. 敦煌网平台为了激励广大商户大额批发交易，降低商户运营成本，采用统一佣金率，实行下列哪种政策？（ ）

- A. 阶梯佣金
- B. 统一佣金
- C. 5%佣金
- D. 递增佣金

11. 跨境电商国际物流术语“实际离港时间”的英文缩写是（ ）

- A. ETA
- B. ETD
- C. ATA
- D. ATD

12. 选择正确的选项补全句子。

Search for products by entering the or into the Search Bar at the top of any AliExpress page. ()

- A. product name; keyword
- B. B. product title; password
- C. product name; security code
- D. D. shop name; keyword

13. 请仔细阅读英文语句，并选择合适的选项补全该句：G-mart Wireless Sport Headphone with mic and Bluetooth 4.1, made () Cellphones as Samsung.

- A. for
- B. by
- C. on
- D. with

14. 速卖通平台中，曝光量能反映出卖家关于产品信息存在的问题，如果曝光量反映出产品很少被买家搜到，则最大的问题是（ ）。
- A. 产品图片缺乏吸引力
 - B. 标题里的词都太生僻或不符合买家的语言习惯
 - C. 标题里的大词比较多，缺少属性词和流行词
 - D. 产品详细属性填写不完整
15. 订单缺陷率（ODR）英文全称：Order ____ Rate 指收到负面反馈、亚马逊商城交易保障索赔或服务信用卡拒付订单的百分比。请选择横线上的单词。（ ）
- A. Defeat
 - B. Defend
 - C. Defect
 - D. Defense
16. “Our cream is lightweight, fast-absorbing and non-greasy.” 这是某店铺一款面霜的产品描述，请选出句中“non-greasy”的正确解释。（ ）
- A. 不油腻的
 - B. 不易过敏的
 - C. 不脱妆的
 - D. 不防水的
17. 亚马逊平台上卖家选择自行发货，如果客户想要更换更快的物流，以便更快的收到货物，你认为可以给客户更改吗？（ ）
- A. 可以，但需要经过亚马逊平台同意。
 - B. 不可以，因为是按照客户之前既定运输方式发货，且货物已到美国平台已有发货记录。
 - C. 可以，客户补上差价即可安排更换。
 - D. 不可以，操作过程繁琐，且需向亚马逊平台解释。
18. 判断引号中的文字表述是否正确：（ ）
- “速卖通数据纵横-选品专家中的热销页面，属性词所在圆圈的颜色越蓝表示竞争越激烈。”

A. 正确 B. 错误

19. 速卖通平台中，以下哪项简称代表页面浏览量？（ ）

A. GMV B. UV C. SNS D. PV

20. 在速卖通平台中，买家下单后，卖家拒绝发货的行为，属于下列哪种违规行为？（ ）

A. 提价销售 B. 成交不卖 C. 强制搭售 D. 出售侵权商品

（二）实施条件

项目	基本实施条件	备注
场地	每个商务英语实训室配置 40 个操作台面和座位，每个实训室照明通风良好。	必备
设备	每个商务英语实训室配有 1 台服务器、40—50 台计算机，并安装 Office 办公软件，配置局域网。	必备
测评专家	每 40 名考生配备 1 名考评员。考评员要求具备至少二年以上从事跨境电商工作经验或三年以上商务英语实践教学指导经历。	必备

（三）考核时量

考试时间：30 分钟

（四）评分标准

模块总分	评价内容	配分	考核点	备注
跨岗位综合技能 （总分 100 分， 占总评分的 20%）	职业素养与操作规范 （6 分）	2 分	（1）具备跨境电商从业人员基本素质，认真严谨、耐心细致、恪守信誉、实事求是、服从安排，听从指挥、举止文明，记 2 分。	在考试过程中不服从安排、举止不得当者，记 0 分。
		2 分	（2）具备跨境电商从业人员良好的翻译素养，认真严谨，耐心细致，记 2 分。	考试过程中出现与所述能力及素养不符，扣 1-2 分。
		2 分	（3）具备跨境电商从业人员良好的沟通能力、表达能力和合作意识，	考试过程中出现与所述能力及素养不符，扣 1-2 分。

(10分)	操作规范(4分)	2分	待人真诚礼貌，记2分。 (1)具备使用办公设备和Office办公软件的能力，在考核过程中以及考核结束后，不私自更换电脑、不随意关闭或重启电脑，没征求监考老师同意不随意提前或推迟交卷，记2分。	若私自更换电脑、随意关闭或重启电脑，记0分。
		2分	(2)能严格遵守企业6S管理要求(整理、整顿、清扫、清洁、素养、安全)，记2分。	若未遵守企业6S管理要求，记0分。
任务(90分)		18分	B2C跨境电子商务平台产品推广等业务操作环节作答。	从四个选项选择一个最适合的答案，每题4.5分，多选、错选、漏选，均不得分。
		18分	B2C跨境电子商务平台产品开发等业务操作环节作答。	从四个选项选择一个最适合的答案，每题4.5分，多选、错选、漏选，均不得分。
		18分	B2C跨境电子商务平台引流营销等业务操作环节作答。	从四个选项选择一个最适合的答案，每题4.5分，多选、错选、漏选，均不得分。
		18分	B2C跨境电子商务平台客户服务等业务操作环节作答。	从四个选项选择一个最适合的答案，每题4.5分，多选、错选、漏选，均不得分。
		18分	B2C跨境电子商务平台规则等业务操作环节作答。	从四个选项选择一个最适合的答案，每题4.5分，多选、错选、漏选，均不得分。
		18分	B2C跨境电子商务平台规则等业务操作环节作答。	从四个选项选择一个最适合的答案，每题4.5分，多选、错选、漏选，均不得分。
		18分	B2C跨境电子商务平台规则等业务操作环节作答。	从四个选项选择一个最适合的答案，每题4.5分，多选、错选、漏选，均不得分。

					得分。
--	--	--	--	--	-----

20. 试题编号：3-1-20 跨境电商平台综合应用能力

（一）任务描述

内容：仔细阅读命题，就 B2C 跨境电子商务平台产品推广、产品开发、引流营销、客户服务、平台规则等业务操作环节作答。

要求：从 A、B、C、D，四个选项中选择一个最适合的答案，每题 1 分，多选、错选、漏选，均不得分。

1. 企业直接面向消费者销售产品和服务是一种商业零售模式，通常我们使用什么英文缩写来表示该商业模式？（ ）

- A. B2B B. B2C C. C2C D. O2O

2. 美国社交网络服务网站 Facebook（脸书）的主要创始人是下面哪一位？（ ）

- A. 马化腾 B. 马克·扎克伯格
C. 马云 D. 埃隆·马斯克

3. UV——Unique _____，是指通过互联网访问、浏览这个网页的自然人。访问这个网站的一台电脑客户端为一个访客。请选择横线上的单词。（ ）

- A. Volume B. Visitor C. Valuate D. Vacuum

4. 下列哪件商品可以在亚马逊平台美国站上销售？（ ）

- A. 手机壳 B. 名贵烟丝
C. 象牙刀柄 D. 银行票据

5. 判断引号中的文字表述是否正确。（ ）

“Wish 平台卖家发现一笔交易从“未处理”订单队列中消失了，说明该订单可能被买家取消了或者正处于审核状态中。如果该订单不再出现于“未处理”订单队列中，那么卖家无需对此订单发货。”

A. 正确 B. 错误

6. 在客户关系管理中，RFM 模型分类方法是被广泛运用的，也是非常直观简捷的工具，那么其中的“M”指什么？（ ）

- A. 消费频率，即在单位时间内的消费次数
- B. 最近的一次消费，客户上一次在店铺成交的时间和成交的产品
- C. 消费金额，单位期间内的消费总额
- D. 产品属性，客户最近一次所购买的产品属性

7. 在 Wish 平台，要成为诚信店铺，延迟发货率 \leq （ ）

- A. 3% B. 5% C. 10% D. 15%

8. 在 eBay 平台，如果一个买家参与一次拍卖，但最后并未赢得竞拍，在拍卖结束后的（ D ）天内，卖家可以为其提供一个“second chance offer”。

- A. 7 B. 10 C. 30 D. 60

9. eBay 平台卖家使用“eBay 亚太物流平台线上国际 e 邮宝”发货至美国时，eBay 亚太物流平台会自动上传跟踪号码。请问此物流跟踪号码的正确格式是？（ ）

- A. 16 个字符/数字 B. LQ+9 个数字+CN
- C. LK+9 个数字+CN D. 21 个字符/数字

10. 下列哪个是速卖通平台允许销售的产品？（ ）

- A. 罂粟 B. 枪支弹药
- C. 旅行箱 D. 医疗器具

11. 根据速卖通平台的“违背承诺”处罚规则，下列有关违规行为与处罚措施的说法，不正确的是（ ）

- A. 违背承诺一般违规，处罚措施为 1 分/次
- B. 违背承诺严重违规，处罚措施为 3 分/次
- C. 违背承诺情节特别严重，处罚措施为 48 分/次
- D. 违背承诺超级恶性违规，处罚措施为 64 分/次

12. 注册亚马逊卖家账号过程中，“Seller Information”页面中“Display name”表示的是以下哪个含义？（ ）

- A. 注册办公地址 B. 公司名称
- C. 店铺名称 D. 法人名字

13. Each platform has its own slogan. Check the slogan of the following platform and pick out the wrong options. ()

- A. AliExpress—Smarter Shopping, Better Living!
- B. DHgate.com—Buy Globally Sell Globally
- C. Wish—Shopping Made Fun
- D. Amazon.com—Shopping Made Fun

14. 在速卖通平台，卖家的每日服务分采用百分制考核方式，每天更新。每日服务分等于需要考察的各个考核单项得分之和，请问每日服务分考核不包含哪个考核项？ ()

- A. 成交不卖率得分、未收到货物纠纷提起率得分
- B. 货不对版纠纷提起率得分、DSR 商品描述得分
- C. DSR 卖家服务得分、DSR 物流服务得分
- D. 48 小时发货率得分、好评率得分

15. eBay 平台中，关于 WINIT 海外仓产品条码的标签贴法，描述不正确的有是 ()。

- A. 贴在产品外包装最小面的左上角
- B. 贴在产品外包装最小面的右上角
- C. 若产品外包装最小面面积过小不适宜贴标签，即贴在适合贴标的平面上并且同种产品规格要统一方向
- D. 标签须清晰可辨认、可扫描

16. 关于 Wish 平台的履行订单政策，以下哪些表述不正确的是 ()

- A. 如果一个订单在 5 天内未履行完成，它将被退款并且相关的产品将被下架
- B. 如果商户的履行率非常低，其账户将被暂停
- C. 如果卖家只有一个订单未在 5 天内完成将不会对产品和店铺造成影响

D. 如果因未按期履行订单而导致的订单退款数量非常高,其账户将被暂停

17. 选择合适的选项补全句子。

We will send the items _____ 3 days once your payment is _____ .
()

A. with, completing B. within, completed

C. within, completing D. for, complete

18. 选择合适的选项补全句子。

The buyer should make sure that the items _____ are in their _____ conditions. ()

A. return, original B. returned, original

C. returns, originally D. return, originally

19. 不属于买家维护三大基础的是()

A. 发货前要严把产品质量关 B. 加强把控物流环节

C. 物流过程与买家及时沟通 D. 以公司利益为先

20. 在亚马逊平台中,下列哪种商品可在商品详情页面中称作“黄金”商品? ()

A. 18K 镀金黄铜商品 B. 14K 金商品

C. 24K 金商品 D. 12K 镀金商品

(二) 实施条件

项目	基本实施条件	备注
场地	每个商务英语实训室配置 40 个操作台面和座位,每个实训室照明通风良好。	必备
设备	每个商务英语实训室配有 1 台服务器、40—50 台计算机,并安装 Office 办公软件,配置局域网。	必备
测评专家	每 40 名考生配备 1 名考评员。考评员要求具备至少二年以上从事跨境电商工作经验或三年以上商务英语实践教学指导经历。	必备

(三) 考核时量

考试时间：30 分钟

(四) 评分标准

模块总分		评价内容	配分	考核点	备注
跨岗位综合技能 (总分 100 分, 占总评分的 20%)	职业素养与操作规范 (10 分)	职业素养 (6 分)	2 分	(1)具备跨境电商从业人员基本素质,认真严谨、耐心细致、恪守信誉、实事求是、服从安排,听从指挥、举止文明,记 2 分。	在考试过程中不服从安排、举止不得当者,记 0 分。
			2 分	(2)具备跨境电商从业人员良好的翻译素养,认真严谨,耐心细致,记 2 分。	考试过程中出现与所述能力及素养不符,扣 1-2 分。
			2 分	(3)具备跨境电商从业人员良好的沟通能力、表达能力和合作意识,待人真诚礼貌,记 2 分。	考试过程中出现与所述能力及素养不符,扣 1-2 分。
		操作规范 (4 分)	2 分	(1)具备使用办公设备和 Office 办公软件的能力,在考核过程中以及考核结束后,不私自更换电脑、不随意关闭或重启电脑,没征求监考老师同意不随意提前或推迟交卷,记 2 分。	若私自更换电脑、随意关闭或重启电脑,记 0 分。
			2 分	(2)能严格遵守企业 6S 管理要求(整理、整顿、清扫、清洁、素养、安全),记 2 分。	若未遵守企业 6S 管理要求,记 0 分。
		任务 (90 分)		18 分	B2C 跨境电子商务平台产品推广等业务操作环节作答。
			18 分	B2C 跨境电子商务平台产品开发等业务操作环节作答。	从四个选项中选择最适合的答案,每题 4.5 分,多选、错选、漏选,均不得分。

			18分	B2C 跨境电子商务平台引流营销等业务操作环节作答。	从四个选项选择一个最适合的答案,每题 4.5 分,多选、错选、漏选,均不得分。
			18分	B2C 跨境电子商务平台客户服务等业务操作环节作答。	从四个选项选择一个最适合的答案,每题 4.5 分,多选、错选、漏选,均不得分。
			18分	B2C 跨境电子商务平台规则等业务操作环节作答。	从四个选项选择一个最适合的答案,每题 4.5 分,多选、错选、漏选,均不得分。
			18分	B2C 跨境电子商务平台规则等业务操作环节作答。	从四个选项选择一个最适合的答案,每题 4.5 分,多选、错选、漏选,均不得分。
			18分	B2C 跨境电子商务平台规则等业务操作环节作答。	从四个选项选择一个最适合的答案,每题 4.5 分,多选、错选、漏选,均不得分。